

Dariusz Witczak
*Józef Golański

Department of Technical Mechanics
and Informatics Computer Science,

*Department of Mechanics of Textile Machines,
Technical University of Lodz
ul. Żeromskiego 116. 90-543 Łódź, Poland

Selected Aspects of the Yarn Formation with a False-twist Method in the Air-jet Spinning Chamber

Abstract

Some selected aspects of the yarn formation in the air-jet false-twist spinning chamber operating according to the MJS (Murata Jet Spinning) principle were discussed. The chamber under investigation is characterised by a straight inlet channel and a separated supply zone to avoid contact of the yarn being formed with air jets before their homogenisation. Two phases of the process: namely, its start-up and spinning under steady conditions, have been presented. The yarn shape photographs at the chamber outlet were made, and the forces existing in the yarn as well as the yarn rotational speed were determined as well.

Key words: air-jet spinning, false-twist chamber, yarn formation.

results concerning this method can be found, among others, in Nakahara T. [2], Klein W. [4], Oxenham W., Basu A. [5], Miao M., Chen R. [6]. In [3], Miao M., Oxenham W., Grosberg P. describe a traditional solution, in which there are two spinning chambers arranged one after another that twist a stream of fibres in opposite directions. They also present a mechanism of false twist formation in air-jet spinning. Kowalczyk L., Kubica H., Gaca T. in [7] have discussed an effect of the yarn velocity on its quality. The spinning procedure employing this method has also been described by Jabłoński W. and Jackowski T. in [8].

In the late 1990's, within the frame of the research project granted by the Committee for Scientific Research and entitled 'Optimisation of technical parameters of the universal spindleless spinning method', at the Textile Research Institute, Łódź, under the supervision of Józwicki R., a new original pneumatic spinning method (IW) was developed.

This method combines the properties of two spinning ways, that is MJS (Murata Jet Spinning) and OE (Open End). The chamber has a forked (Y-shaped) inlet channel and the yarn thus obtained has a true, one-directional twist. This way of yarn formation has been described by Józwicki R. in [9].

The investigations conducted by the authors within the above-mentioned project have been employed in the present study.

Subject, aim and scope of the study

An overpressure, small-diameter, false-twist spinning chamber operating in the MJS system is the subject of the present

study. It can be treated as one of the geometrical variants of the IW method that differs from it by a straight inlet channel. The chamber can operate independently or as the first chamber in a system of two. The air flow in this chamber has been presented by Witczak D. and Golański J. in [12].

The investigations discussed in this study concern mainly spinning with one chamber and one kind of the raw material the yarn is made of. The presented scope of these investigations is aimed at the description of some selected aspects of spinning, which will be the basis for development of a computer model of the chamber and optimisation of spinning process parameters. Further technological investigations of the chamber under consideration are planned in the future.

This study is aimed at the description of some selected aspects of the yarn formation in the spinning chamber with a straight inlet channel and a separated supply zone with the false-twist spinning (MJS) method.

The yarn formation will be discussed in two phases of the process, namely:

1. start-up of spinning,
2. spinning under steady conditions.

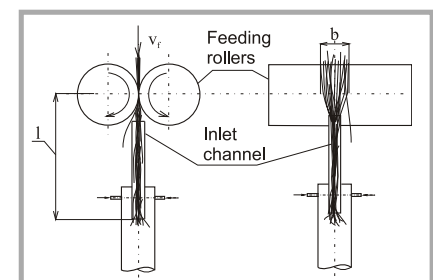

Figure 1. Illustration of the start-up of the spinning process: v_f – fibre supply velocity, b – fibre supply tape width.

Introduction

Yarn formation in an air-jet spinning chamber in which the yarn is formed from staple fibres exclusively as a result of the swirled air-jet action has been attractive from the viewpoint of the process speed and intensity. Nowadays chambers in air-jet spinning frames employ the MJS (Murata Jet Spinning) method. In comparison with other methods, this spinning method enables to miniaturise the spinning chamber (the swirl chamber diameter equals 3 – 3.5 mm), to supply it with compressed air (overpressure chamber), and to improve the yarn quality. The yarn obtained thus almost has an untwisted carrier that is braided on the yarn surface. There are many publications in world literature in which this spinning method has been discussed. Investigation

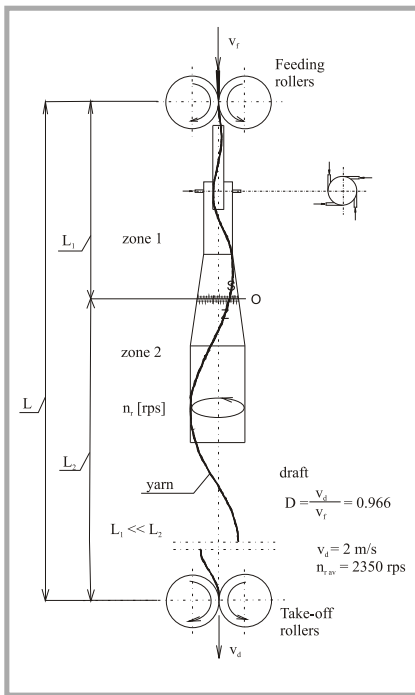

Figure 2. View of the yarn in the chamber; v_f – fibre supply velocity, v_d – yarn delivery velocity, D – draft ratio, n_r – rotational speed of the yarn, S , Z – kind of yarn twist, L – length between the feeding and take-off rollers, L_1 – length of the zone with a twist S of the yarn, L_2 – length of the zone with a twist Z of the yarn.

All the investigation results presented in this study, for which the operating conditions in the chamber have not been described separately, refer to the following process parameters:

- air supply pressure $p_n = 0.7$ MPa,
- yarn delivery velocity $v_d = 2$ m/s,
- yarn linear mass 36 tex,
- yarn made of polyester + cotton (E50B50),
- draft ratio $D = 0.966$.

These parameters have been assumed to be optimal and have been determined on the basis of initial tests.

■ Start-up of spinning

The start-up of the spinning process begins with putting the feeding rollers into motion under normal air flow in the spinning chamber that has been described in Section 3 of [12]. This phase is illustrated in Figure 1.

Elementary fibres transported by feeding rollers with the velocity v_f , flattened in the form of a thin, untwisted tape of the width b , must be sucked automatically into the inlet channel. In order to make it possible, the inlet channel is maximally

close to the feeding rollers. In the channel the fibres that are one-sided seized by the feeding rollers displace untwisted to the swirl chamber with the velocity v_f as the air jet in the inlet channel is not swirled. The fibres are under tension, and are pulled out from the seizure by the force of the magnitude 240 m/s that results from the air velocity in the channel. Under such conditions, in order to maintain the continuity of supply, that is to say, to avoid a break in the feeding stream of fibres before it is twisted, the length of the inlet channel l has to be significantly lower than the length of the fibres. Having entered the swirl chamber, the stream of fibres is thrown towards the chamber wall and twisted by the swirled air jet into a yarn with a true, one-directional twist (open-end (OE) spinning) as an effect of the centrifugal force. The yarn leaves the chamber automatically in this form. This phase of spinning is finished by introducing the yarn into the take-off rollers, and seizing its segment between the feeding and take-off rollers, which results in a change of the yarn formation way into the false-twist method (MJS).

■ Spinning under steady conditions

A view of the yarn in the chamber under steady spinning conditions is shown in Figure 2. The flow conditions have been discussed in Section 4 of [12].

The shape of the yarn behind the chamber was recorded photographically with a very short flash of the duration 1.8×10^{-6} s. A sample photograph of the yarn shape is shown in Figure 3.

The yarn has the approximate form of a helix with an opposite packing direction to the direction of the air swirl. The opposite direction of the yarn packing follows from a decrease in the circumferential component of the air velocity with an increase in the distance from the nozzles, up to zero beyond the spinning chamber (still air). The yarn spins along the direction of the drive with the speed of, for instance, $n_r = 2200 - 2500$ r.p.s., touching the chamber wall. Under the same conditions the spiral lead, and thus the shape of the yarn, is time-variable in quite a wide range. The speed and direction of yarn spinning has been established on the basis of the analysis of the photographs made with two flashes, whose time interval was controlled and measured at the

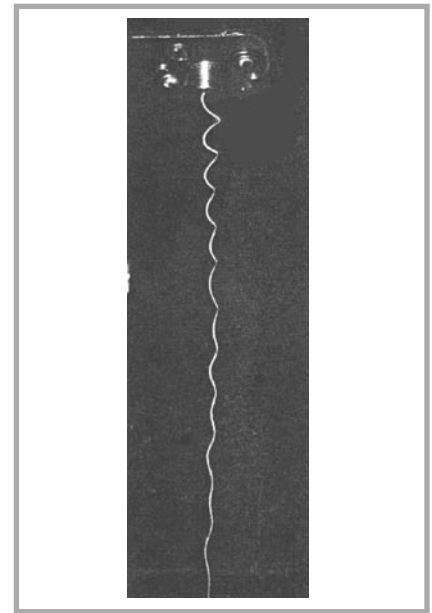

Figure 3. Photograph of the yarn beyond the spinning chamber.

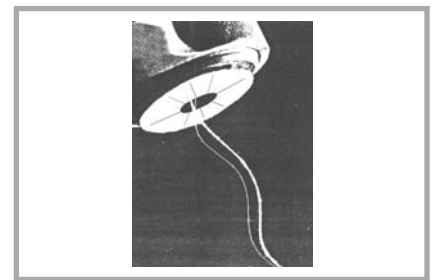

Figure 4. Photograph of the yarn made at the chamber outlet by means of two flashes.

chamber outlet. An exemplary photograph of the yarn made with this method is presented in Figure 4.

As a result of spinning, the yarn segment seized between the feeding and take-off rollers is twisted in such a way that it obtains a twist S between the feeding rollers and the swirl chamber (zone 1, Figures 2 and 5) under the conditions discussed, whereas the segment between the swirl chamber and the take-off rollers (zone 2) has a reverse twist Z . The length of the seized yarn segment (L_y) due to its shape is higher than the distance L between the rollers.

The analysis of the twisting process will be started on the arbitrary assumption that twisting is performed with feeding and take-off rollers stopped. A scheme of the twisting process in this case is shown in Figure 5.

A segment of the ready yarn, resistant to the defibering effect of the air jet, of the length $L_y > L$, was fixed to the measuring

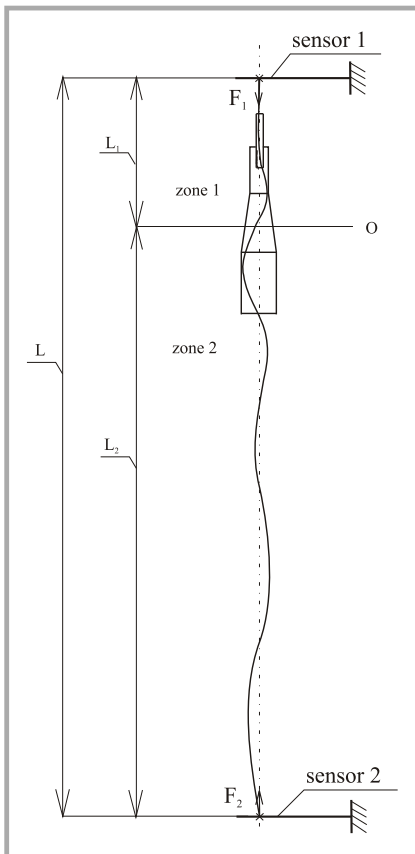

Figure 5. Schematic view of the twisting process with the feeding and take-off rollers stopped; L – distance between the tension (force) gauges, L_1 – length of the zone with a twist S of the yarn, L_2 – length of the zone with a twist Z of the yarn, F_1 , F_2 – yarn tension (force).

tips of two tension gauges to measure tension (force). The gauges were distant by L from each other in such a way that the spinning chamber assumes the same

position with respect to the sensors as to the axes of feeding and take-off rollers. As a measure of the yarn surplus, the quotient L/L_y was assumed. As a result of the total influence of the chamber and the twisting process, time histories of the tensions (forces) F_1 and F_2 (Figure 5) were recorded. The recording started automatically when the tension (force) F_1 exceeded the arbitrary value F_0 . In Figure 6, the time function of F_1 is shown, whereas Figure 7 presents the time function of F_2 .

The static characteristic curve, determined since the moment in which a mean value of tension becomes steady, is drawn over these time histories. The static characteristics comprise: a histogram, a mean value, a standard deviation and a coefficient of tension variability.

After the same time for both time histories (τ_0), the mean values become constant at the same level, so that $F_{1av} > F_{2av}$. A difference between tensions (forces) is a result of the tension (force) increment in the chamber due to the air-jet effect. A higher scatter of the tension (force) F_2 results from yarn spinning in an open space after leaving the chamber. The fact that after the time τ_0 , the value of the mean tension (force) becomes constant proves that a constant average number of twists T_t establishes both in zone 1 and in zone 2 as well. Twists added above T_t in zone 1 pass through a friction barrier and remove the same number of twists in zone 2. As

a result, $T_{t1} = T_{t2}$ according to the false-twist theory. The lengths of these zones are different, however, thus the number of twists T_{tm} referred to 1 metre of the yarn follows from the equality:

$$\frac{T_{tm1}}{T_{tm2}} = \frac{L_2}{L_1} \quad (1)$$

As $L_2 \gg L_1$, then $T_{tm1} \gg T_{tm2}$, which justifies the statement that twists from zone 1 transfer to zone 2.

During the analysis of the diagrams of the tension F_2 , it was found that they could be used in the evaluation of the yarn rotational speed. In Figure 8, time functions of the tension F_2 , in which a periodicity of changes in tension corresponding to yarn rotations is clearly visible, are presented.

On the basis of these diagrams, it is easy to define the mean time of one rotation τ and the yarn rotational speed n_r corresponding to it. The quantity n_r determined in this way is a suitable criterion for the evaluation of the influence of conditions or geometry of the chamber on the yarn rotational speed (supply pressure p_n , Figure 8, in the example quoted).

The case of twisting when the rollers do not move illustrates well a positive property of the yarn - a chamber system that consists in the fact that the system self-adjusts to changes in the process parameters, for instance, to the yarn length L_y . In Table 1, an influence of the increase in the yarn length L_y on the twisting process is shown.

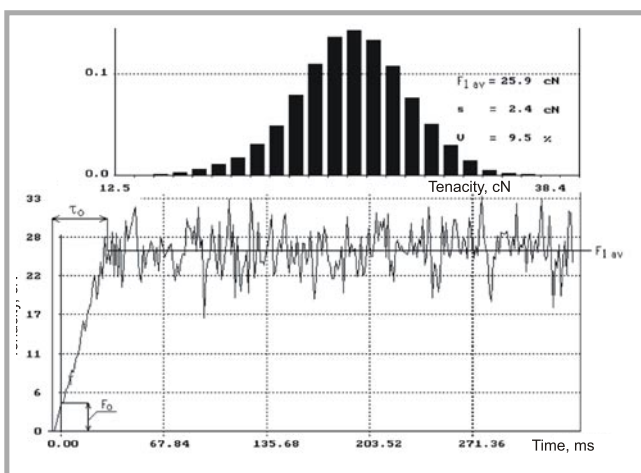

Figure 6. Yarn tension (force) F_1 vs. time (in front of the chamber): a – yarn tension (force) vs. time, b – static characteristics of the time function: F_0 – value of the yarn tension (force) at which the measurement apparatus is switched on, τ_0 – time after which the conditions become steady, F_{1av} – mean yarn tension (force), s – standard tension (force) deviation, v – coefficient of tension (force) variability.

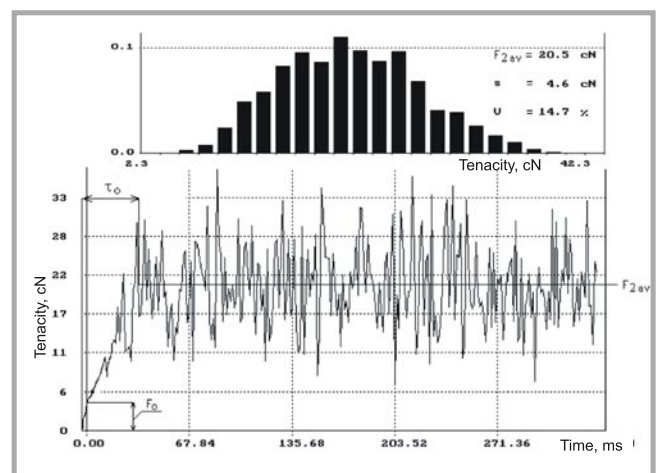

Figure 7. Yarn tension (force) F_2 vs. time (behind the chamber): a – yarn tension (force) vs. time, b – static characteristics of the time function: F_0 – value of the yarn tension (force) at which the measurement apparatus is switched on, τ_0 – time after which the conditions become steady, F_{2av} – mean yarn tension (force), s – standard tension (force) deviation, v – coefficient of tension (force) variability.

Table 1. Values of the tensions F_1 and F_2 as a function of the yarn length (L/L_y).

L/L_y		0.99	0.96	0.92
F_1	$F_{1\text{ av}}$, cN	34.1	27.6	21.4
	s, cN	3.4	2.7	1.7
	v, %	10.2	10.1	8.3
F_2	$F_{2\text{ av}}$, cN	29.7	21.6	15.2
	s, cN	5.0	4.5	4.2
	v, %	12.4	13.8	15.6
n_r , r.p.s.		1900	2000	1950

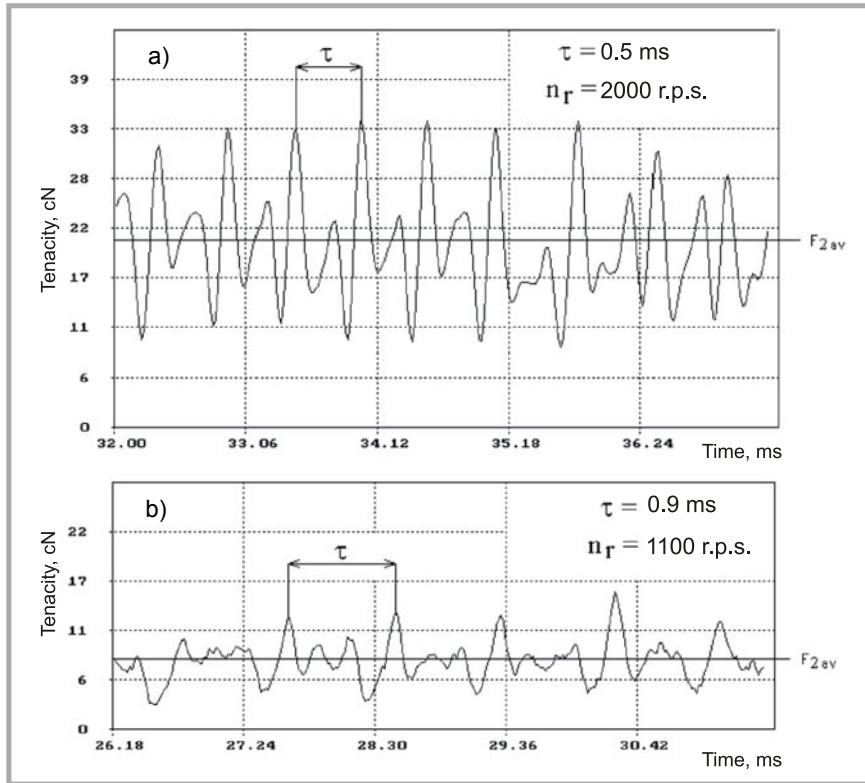

Figure 8. Tension F_2 as time functions of the supply pressure; a) $p_n = 0.7$ MPa, b) $p_n = 0.3$ MPa; τ – duration of one cycle of a change in the yarn tension (force), $F_{2\text{ av}}$ – mean yarn tension (force), n_r – yarn rotational speed.

The values of (L/L_y) were assumed on the basis of tensions used in the initial tests and the investigations presented in [9].

An increase in the yarn length L_y results only in a decrease in the yarn tension (force) and a change of the yarn shape that is related to it, but does not disturb the twisting process – the rotational speed n_r remains constant in fact.

Under normal, steady-in-time conditions of spinning, the yarn rotates with a mean speed $n_r = 2350$ r.p.s. and it is taken off at the velocity $v_d = 2$ m/s. If it is assumed that the yarn in one rotation obtains one twist, then the boundary, feasible number of twists per 1 metre is equal to: $T_{mb} = n_r/v_d = 1175$ twists/m. In order to obtain this boundary number of twists:

- the sufficient length L_1 - under the presented conditions, not lower than 40 mm,
- the sufficient friction force T (Figure 9) to maintain these twists (Figure 9) are necessary.

A scheme that explains the yarn formation under steady conditions is presented in Figure 9.

The true number of twists T_{tm} can be lower than T_{mb} due to both the reasons mentioned. The length L_1 cannot be determined experimentally, it is only known that the theoretical line "0" (Figures 5 and 9) goes through the swirl chamber at the point of the first contact of the yarn with the wall or below it and can be a segment of a finite length oscillating within certain limits with respect to the mean position, determined by the expect-

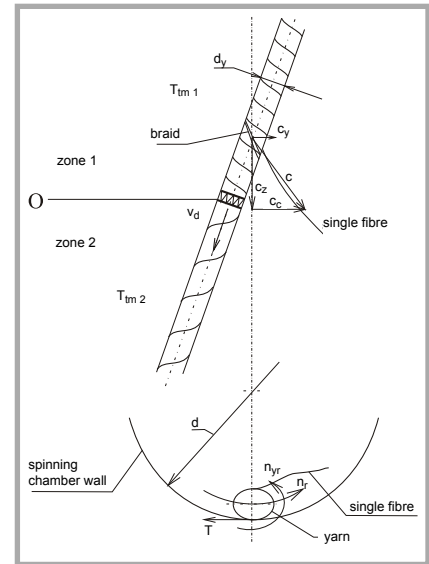

Figure 9. Scheme of the yarn formation under steady conditions; d – spinning chamber diameter, d_y – yarn diameter, T – friction force of the yarn against the spinning chamber, c_c – circumferential component of the air velocity, c_z – axial component of the air velocity, c – air velocity, c_y – yarn velocity, n_r – yarn rotational speed in the spinning chamber, n_{yr} – yarn rotational speed (around its axis), v_d – yarn delivery velocity, T_{tm1} , T_{tm2} – true number of yarn twists.

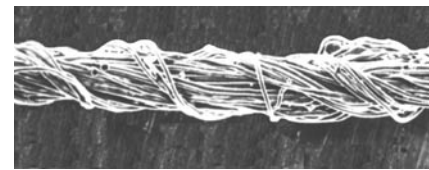

Figure 10. Photograph of the yarn with braids [7].

ed length L_1 . It also seems that an instantaneous value of the moment of friction with respect to the yarn axis, as well as the rotational speed itself, change in a similar way as the yarn tension (force) and the yarn shape beyond the chamber. If we assume that the mean value of T_{tm} is not significantly (several times) lower than T_{mb} , then T_{tm1} is sufficient to ensure the necessary yarn strength in zone 1, whereas T_{tm2} is too low to maintain the continuity of the spinning process. Thus, a conclusion can be drawn that the braids shown in Figure 10 that decide the yarn strength and structure [3, 7, 8] arise in the first part of the swirl chamber, in front of plane "0". An analysis of the fibre arrangement in the braid points out the fact that the braid is made by multiple braiding of the yarn core with a fibre or a group of boundary fibres at a minimal pitch, distinctly lower than the yarn diameter d_y . It shows that the braids

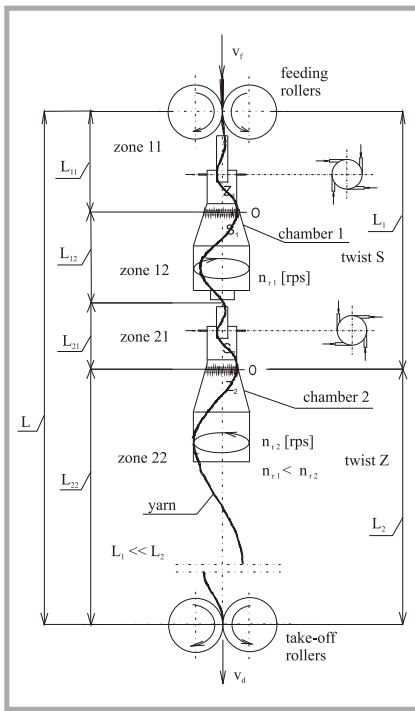

Figure 11. Scheme of the twisting process in a system of two spinning chambers; v_f – fibre supply velocity, v_d – yarn delivery velocity, n_{r1} , n_{r2} – yarn rotational speed, S , Z , S_1 , S_2 , Z_1 , Z_2 – kind of the yarn twist, L – distance between the feeding and take-off rollers, L_1 – length of the zone with a twist S of the yarn, L_2 – length of the zone with a twist Z of the yarn, L_{11} , L_{12} , L_{21} , L_{22} – lengths of the zones in the system of two chambers.

result from rotations of the yarn around its own axis in the twisting process or through the releasing of twists (transfer of twists from zone 1 to zone 2). During braiding a fibre has to be under tension. The direction of yarn rotations n_{yr} does not matter. Only these windings are efficient in which a free end of the fibre will be seized in the core or the braid, which protects the braid against its loosening. The fibre tension during the braid formation results from the fact that it contacts the chamber wall and that the air jet is much faster than the yarn being formed (Figure 9). Such conditions arise both in the inlet channel and in the swirl chamber. In the inlet channel, a free fibre will be laid along the direction that results from the superposition of the twisting speed n_{yr} and the axial velocity of the air flow under steady spinning conditions – of the magnitude of 130 m/s. Effects of the air jet in the swirl chamber and the arrangement of the fibre that forms a braid are illustrated in Figure 9.

The presented chamber can operate separately (as has been described above) or a second chamber in a two-chamber

system. A scheme of the twisting process in the case of two chambers is presented in Figure 11.

As a rule, the directions of the air vortex in chambers are opposite [3, 7, 8]. If the following condition is fulfilled additionally:

$$\frac{S_1 + S_2}{L_{12} + L_{21}} > \frac{Z_1}{L_{11}} \quad (2)$$

then twists of the direction S from zones L_{12} and L_{21} go to zone L_{11} , and having removed twists of the direction Z , they make twists of the direction S appear. As a result, in a two-chamber system the arrangement of twists is similar as in the case of a single chamber, with such a difference that twists S in zone L_{11} are obtained at the opposite direction of yarn rotations. It makes the braiding easier by increasing the number of windings in a braid and the yarn quality [3, 7]. When the necessary number of twists T_{tm1} is obtained, then the yarn rotational speed can be decreased in chamber 1 with respect to chamber 2, for instance through decreasing the supply pressure or inclining tangent supply nozzles towards the outlet.

According to the false-twist theory, the yarn segment that has passed through the whole formation zone L should have an untwisted core. In fact, at the outlet of the take-off rollers, a low number of twists, much lower than T_{tm2} , transferred from zone 2, remains.

Conclusions

1. The yarn in the formation zone between feeding and take-off rollers has a form of a helix with an opposite inclination to the air vortex direction, and it rotates along the drive direction with the speed of 2200 – 2500 r.p.s.
2. The yarn in the spinning start-up process is formed according to the open-end (OE) principle.
3. The number of twists in the yarn between the chamber and take-off rollers is too low to ensure sufficient strength of the yarn that guarantees the continuity of the spinning process.
4. The braids that bind the untwisted yarn core arise in the first part of the chamber as a result of the yarn rotation around its axis in the process of twisting or twist releasing.
5. The measurement of yarn tension (force) during twisting under stopped

yarn transport allows for an evaluation of its rotational speed.

The initial tests have shown the usefulness of the presented chamber for air-jet spinning.

The operation tests of the chamber under consideration will be continued in further projects.

References

1. Grosberg P., Oxenham W., Miao M.; Insertion of 'twist' into yarns by means of air jets. I. An experimental study of air-jet spinning. II. Twist distribution and twist insertion rates in air-jet twisting., *Journal-of-the-Textile-Institute*. Vol. 78, No.3, (1987) pp. 189-219.
2. Nakahara, T.; *Air-jet Spinning Technology*. Text. Tech. Int., (1988): pp. 73-74.
3. Miao M., Oxenham W., Grosberg P.; Yarn formation in a pneumatic system. *Przeegląd Włókienniczy* 1988, pp. 360 - 364 (in Polish).
4. Klein, W.; *New Spinning Systems*. The Textile Institute Manual of Textile Technology, Stephen Austin and Sons Limited, UK, 1993.
5. Oxenham, W. Basu A.; Effect of Jet Design on the Properties of Air-jet Spun Yarns. *Textile Res. J.*, Vol. 63, No. 11, (1993) pp. 674-678.
6. Miao, M., Chen, R.; Yarn Twisting Dynamics. *Textile Research Journal*, Vol. 63 No. 3, 1993.
7. Kowalczyk L., Kubica H., Gaca T.; Influence of the spinning speed on the quality of the yarn formed with the pneumatic false-twist method. (in Polish) *Przeegląd Włókienniczy*, Łódź 1994/2
8. Jabłoński W., Jackowski T.; *Modern spinning systems*. Bielsko-Biała 2001 (in Polish).
9. Józwicki R. Mechanism of formation and tensile properties of the yarn made with a new spindleless spinning method. (in Polish) *Reports of the Textile Research Institute*, vol. XLIX, Łódź 2002.
10. Basal G., Oxenham W., Vortex spun yarn vs. air-jet spun yarn. *Autex-Research-Journal*. Vol. 3, No. 3 (2003) pp. 96-101.
11. Oxenham W., *Spinning*. *Textile-World*. 2004; 154(1).
12. Witczak D., Golański J., Air flow in the air-jet false-twist spinning chamber. *Fibres & Textiles in Eastern Europe*, Vol. 15, No. 3(62) 2007 pp. .

Received 28.11.2005 Reviewed 15.01.2006