

Xinjin Liu,
Xuzhong Su*,
Tingting Wu

Effects of the Horizontal offset of the Ring Spinning Triangle on Yarn

School of Textile and Clothing,
Jiangnan University,
Wuxi 214122, P. R. China

Key Laboratory of Eco-Textile,
Ministry of Education,
Jiangnan University,
Wuxi 214122, P. R. China
*E-mail: mfgucy@163.com
(liuxinjin2006@163.com)

Abstract

The spinning triangle is a critical region in the spinning process of yarn. Its geometry influences the distribution of fibre tension in the spinning triangle and, thus, affects the properties of spun yarns. Therefore, taking appropriate measures to influence the spinning triangle geometry and thus improve the quality of yarn has attracted great interest in recent years. During the geometry parameters, the horizontal offset of the twisting point to the symmetric axis of the nip line of the spinning triangle d has attracted more and more attention and is considered as one of the most critical factors influencing the quality of yarn. Therefore, in this paper, the effects of the horizontal offset d of the ring spinning triangle on yarn qualities is investigated. Firstly a theoretical model of the fibre tension distributions in the spinning triangle is given. Relationships between the fibre tension and horizontal offset of the spinning triangle are analysed theoretically. Secondly, as an application of the model proposed, the spinning triangles of a modified ring spinning system with a pair of offset devices which can change the horizontal offset 'd' continuously are studied. The distributions of fibre tension in the spinning triangle are simulated numerically, with the horizontal offset varying continuously. Furthermore the properties of spun yarns produced by the modified system are evaluated and analysed by using the simulation results.

Key words: spinning triangle, fibre tension distributions, horizontal offset, yarn.

Introduction

In the ring spinning process, first the fibre strand comes from the draft zone, which is flat, and almost all fibres are parallel to the twisting axis of the strand at this time. Secondly when it is twisted, the fibre strands rotate around the axis and the width begins to decrease. After that the fibres on both sides of the axis fold gradually, roll into the centre of the spun yarn, and the spinning triangle consequently formed [1]. In the spinning triangle, on the one hand, yarn hairiness is produced since the head and tail of the border fibre cannot be involved in the gauze easily, while, the border and central fibre cannot break in twisting simultaneously since their tension is different. Therefore strengthening each fibre can-

not be fully achieved and hence the yarn strength is reduced, i.e. the existence of the spinning triangle has a negative effect on the quality of yarn. On the other hand, the fibres repeated rolling in the spinning triangle makes transfers between the internal and external fibres and enhance friction between fibres, which is beneficial for the yarn strength and wear resistance, i.e. the existence of the spinning triangle has a positive effect on the quality of yarn. Therefore the spinning triangle is a critical region in the spinning process of yarn and its geometry influences the distribution of fibre tension in the spinning triangle, thus affecting the properties of spun yarns, especially the yarn strength, torque and hairiness [2 - 5]. The existence of the spinning triangle has a positive effect not on the quality of yarn, but there are also negative effects. However, because of its objective existence, we should minimise its negative effects and emphasise its positive role, i.e. we should control the spinning triangle reasonably. Therefore, taking appropriate measures to influence the spinning triangle geometry and thus improve the quality of yarn has attracted great interest in yarn spinning recently [4 - 6]. All existing spinning technologies are achieved by changing the ring spinning triangle in some way, such as the Sirospun [7], Solospun [8], Compact spinning [9] and so on.

In recent years, researches on improving the quality of ring spinning yarn by changing the spinning triangle shape actively, especially the horizontal offset of

the twisting point, have attracted more and more attention by achieving fruitful results [10 - 14]. Mismatch Spinning is one of the most effective spinning technologies implemented by mismatching one ring spindle [10]. This new spinning technology is effective for reducing ring spinning yarn hairiness [10, 11], but it also leads to over offset, empty spindles and other problems easily because of mismatching one ring spindle each time. Therefore a kind of yarn guide device is installed between the front roller and yarn guide in order to modify the yarn path while not leading to the empty spindle problem [11]. In a word, Mismatch Spinning is a spinning technology implemented by mismatching one ring spindle in order to change the horizontal offset of the ring spinning triangle and thus improve yarn quality. Another example is the spinning triangle formed in a modified ring yarn spinning system developed by Tao Xiaoming et al. [2 - 4, 12, 13], in which a false twisting device is incorporated into a ring frame for producing low torque and soft handle single yarns [4]. In this system, it is highlighted that the speed ratio, which is defined as a ratio of the ring spindle rotational speed to the false twisting device speed, is a key spinning parameter for obtaining different shapes of the spinning triangle [4]. In a word, the modified ring yarn spinning system changes the shapes of the spinning triangle by regulating the ratio of the ring spindle rotational speed to that of the false twisting device in order to improve yarn quality in some way, such as softer handle, higher yarn strength at lower

twists, lower residual torque and so on [13, 14]. Motivated by all these research works, this paper attempts to investigate the effects of the geometry of the ring spinning triangle on yarn in detail, especially the horizontal offset d in the ring spinning triangle.

Over the past decades, the subject of the spinning triangle has been one of the most important research topics and has attracted more and more attention due to its fruitful results [4, 5, 15 - 21]. Force balances in the spinning triangle was first considered theoretically in a study of the twist irregularity of cotton and worsted spun yarns in ring spinning [15]. Then the structural transformations of fibres at rupture were investigated in a study of the strength of fibre strands in the spinning triangle [16]. Furthermore, considering the different extensions of fibre in the spinning triangle, the strength of the triangle in ring spinning was similarly investigated in [17]. In order to study the geometry of the spinning triangle and its significance for yarn quality, it is emphasised that ring spinning geometry has a certain influence on the process, such as end breakages and yarn structure, in which a long spinning triangle shows a much more uniform distribution of forces [18]. Based on the above analysis, a theoretical model was developed in order to predict the distribution of fibre tension in the spinning triangle by using the principle of stationary total potential energy [20]. In this model, only the symmetric geometry of the spinning triangle was considered. However, in real situations,

the spinning triangles are often asymmetric due to the frictional contacts of fibres with the bottom roller [4, 5]. Therefore this model was further extended to the asymmetric spinning triangle by introducing a shape parameter to describe the skew level of the geometry of the spinning triangle [2]. In all the studies mentioned above, the spinning tension of yarn acting on the convergence is assumed to be perpendicular to the nip line of the front rollers. This treatment is reasonable for a conventional ring spinning process. However, this assumption is not appropriate for modified ring spinning systems in which the yarn spinning tension has an obvious angle with the vertical axis perpendicular to the nip line [4], as shown in the study of a modified yarn path of ring spinning proposed in [19]. Therefore a new theoretical model was proposed by considering the inclination angle of the spinning tension based on the principle of minimum potential energy [4]. Furthermore the quantitative relationships between the mechanical performance of a ring-spinning triangle and the spinning parameters were investigated using the Finite Element Method (FEM) [21].

Motivated by all these research works above, this paper attempts to investigate the effects of the geometry of the ring spinning triangle on yarn quality in detail, especially the horizontal offset d in the ring spinning triangle. With the help of a high-speed camera and modified ring spinning system with a pair of offset devices which can change the horizontal offset d continuously, the distributions of

fibre tension in the spinning triangle are simulated numerically. Correspondingly the properties of spun yarns produced by the modified system are evaluated and analysed using the simulation result.

Theoretical analysis

Models of the spinning triangle with right and left offset are shown in **Figure 1**. Here point C is an initial convergence point without any force; O is the middle point of the nip line, and C' is the twisting point with constant force F_s . For convenience of mathematical analysis, the direction of F_s is assumed to act along the line OC ; m is the half width of the spinning triangle; d is the horizontal offset of the twisting point C' to the symmetric axis of the nip line, and O' is the corresponding twisting point, with $d = 0$. In this paper, the horizontal offset d is a continuous variable and we mainly consider its influence on yarn qualities. α is the inclination angle of the spinning tension, which is that between the line OC and symmetric axis of the nip line OC' . h is the height of the spinning triangle; θ_i is the angle between the right i -th fibre and central fibre; θ_i' is the angle between the left i -th fibre and corresponding central fibre. Supposing that the number of sides of the central fibre is n , i.e. there are $2n + 1$ fibres in the spinning triangle.

For convenience of analysis, we can make the following assumptions: the cross-section of all fibres is circular with identical diameters; all fibres are gripped

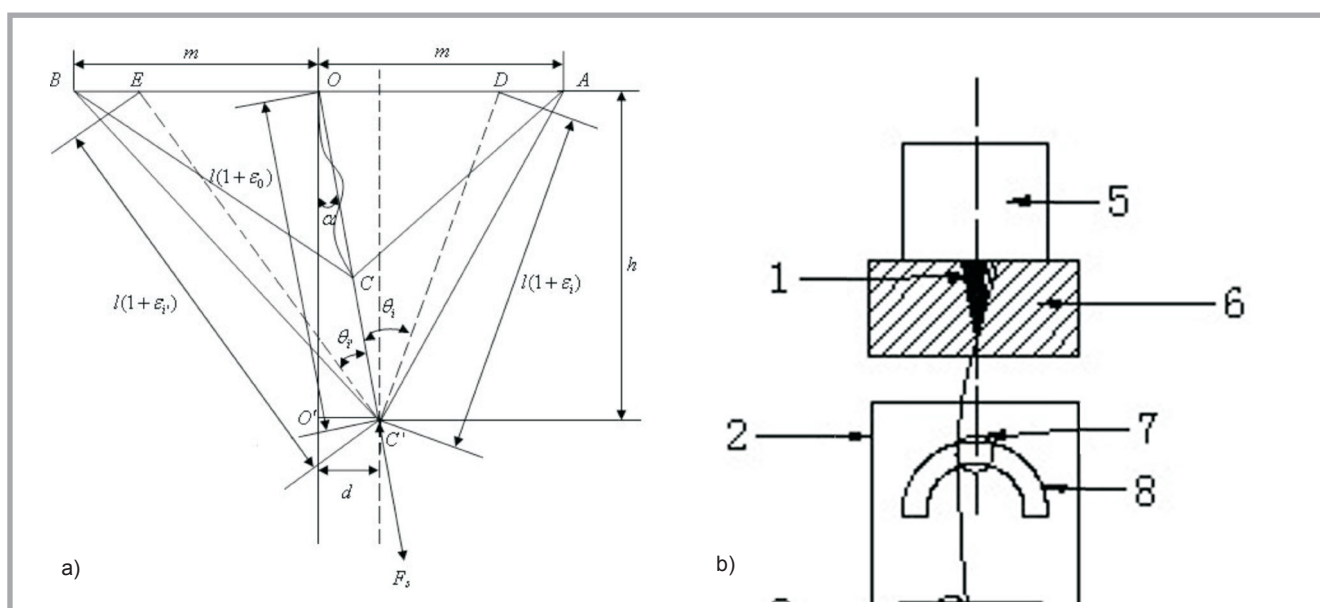

Figure 1. Spinning triangle with: a) right and b) left offset.

between the front roller nip and convergence point C' ; fibre slippage and migration and frictional contacts between fibres and the front roller are not taken into consideration; the velocity of fibres in the spinning triangle is constant, and the fibres' stress-strain behaviour follows Hook's law for small strain.

For the case of right offsets, regarding triangle $OC'D$ and $OC'E$, shown in **Figure 1**, we get the following equations:

$$\cos(\theta_i - \alpha) = \frac{h}{l(1 + \varepsilon_i)} \quad (1)$$

$$\cos(\theta_i + \alpha) = \frac{h}{l(1 + \varepsilon_i')} \quad (2)$$

$$\cos \alpha = \frac{h}{l(1 + \varepsilon_0)} \quad (3)$$

Then, based on the **Equation 1 ~ 3**, we have:

$$\varepsilon_i = M_i \varepsilon_0 + M_i - 1 \quad (4)$$

$$\varepsilon_i' = M_i' \varepsilon_0 + M_i' - 1 \quad (5)$$

where: $M_i = \frac{1}{\cos \theta_i + \tan \alpha \sin \theta_i}$,

$$M_i' = \frac{1}{\cos \theta_i' - \tan \alpha \sin \theta_i'}$$

ε_0 is the central fibre strain, ε_i and ε_i' are the strain of the right i -th fibre and left i' -th fibre, respectively.

Using the principle of minimum potential energy and based on the analysis in [4], the distribution of fibre tension in the spinning triangle can be given as the set **Equations 6**:

Here, $A = \pi r^2$ is the cross-section of fibre, r the diameter of fibre, E is the tensile Young's modulus of fibre.

We further assume that the ends of all fibres gripped in the front roller nip distribute evenly, i.e. $m_i = m_i' = i \cdot m/n$, where m_i is the distance between the end of the i -th fibre on the right side and at point O , and m_i' is the distance of the i' -th fibre on the left side correspondingly. Then, from **Figure 1**, we have

$$\tan \alpha = \frac{d}{h}$$

$$\tan(\theta_i + \alpha) = \frac{m_i + d}{h} = \frac{im + nd}{nh}$$

$$\tan(\theta_i - \alpha) = \frac{m_i - d}{h} = \frac{im - nd}{nh}$$

Therefore, we get

$$F_{i=0,1,\dots,n} = \frac{F_s - AE \left(\sum_{i=0}^n M_i (M_i - 1) + \sum_{i'=0}^n M_{i'} (M_{i'} - 1) \right)}{\sum_{i=0}^n M_i^2 + \sum_{i'=0}^n M_{i'}^2 - 1} M_i + AE (M_i - 1) \quad (6)$$

$$F_{i'=0,1,\dots,n} = \frac{F_s - AE \left(\sum_{i=0}^n M_i (M_i - 1) + \sum_{i'=0}^n M_{i'} (M_{i'} - 1) \right)}{\sum_{i=0}^n M_i^2 + \sum_{i'=0}^n M_{i'}^2 - 1} M_{i'} + AE (M_{i'} - 1)$$

Equation 6.

$$\sin \theta_i = \frac{\tan \theta_i}{\sqrt{(\tan \theta_i)^2 + 1}} \quad (7)$$

$$\cos \theta_i = \frac{1}{\sqrt{(\tan \theta_i)^2 + 1}}$$

$$\sin \theta_i' = \frac{\tan \theta_i'}{\sqrt{(\tan \theta_i')^2 + 1}} \quad (8)$$

$$\cos \theta_i' = \frac{1}{\sqrt{(\tan \theta_i')^2 + 1}}$$

Where $\tan \theta_i = \frac{imh}{nh^2 + nd^2 - imd}$,

$$\tan \theta_i' = \frac{i'mh}{nh^2 + nd^2 + i'md}$$

for $i = i' = 1, 2, \dots, n$.

Based on the analysis above, we know that if we take point O' as the origin, and the horizontal offset d takes a positive value with the right offset, while takes a negative value with the left offset correspondingly, then, for the case of left offsets, we can get the same conclusion as for the right offset. Therefore we know that the distribution of fibre tension in the spinning triangle can be given as in **Equation 6** for the left and right offsets uniformly. In accordance with the above assumptions, in this paper we can state that $-m \leq d \leq m$ and denote the horizontal offset as $|d|$ in the following.

Experiments

From **Equations 4 ~ 8**, we can see that the distribution of fibre tension in the spinning triangle mainly depends on the spinning tension, the horizontal offset, the number of fibres at the roller nip, the tensile Young's modulus and cross-section of fibre as well as on the height and width of the spinning triangle. In the general case, the height of the spinning triangle h changes with the varying of

the horizontal offset $|d|$. However, this kind of treatment is found to be difficult to solve. Therefore we assume that the height of the spinning triangle h is constant with the varying of the horizontal offset $|d|$ in the following discussions. From the twisting process of ring spinning, we know that the width of the spinning triangle is constant with the varying of the horizontal offset $|d|$.

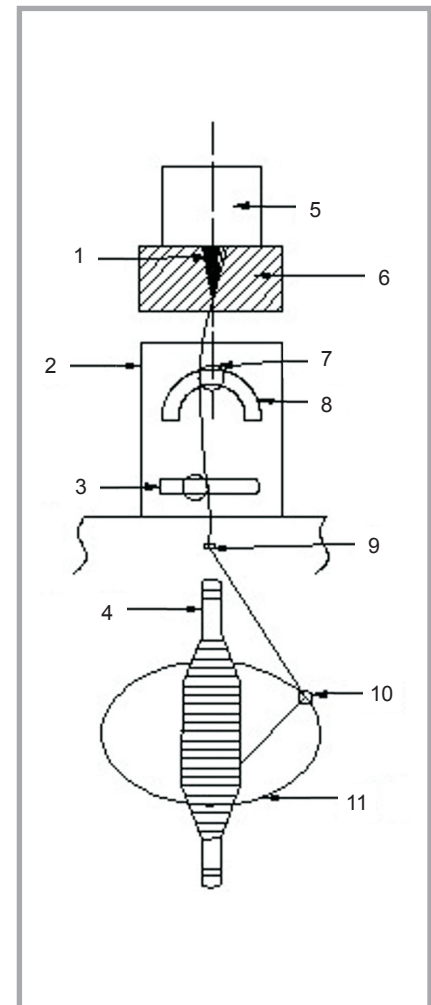

Figure 2. Diagram of the ring spinning system with offset device; 1 - spinning triangle, 2 - bracket, 3 - locating yarn round, 4 - bobbin, 5 - front cots, 6 - front roller, 7 - locating yarn round, 8 - locating slot, 9 - yarn guide, 10 - traveler, 11 - bobbin.

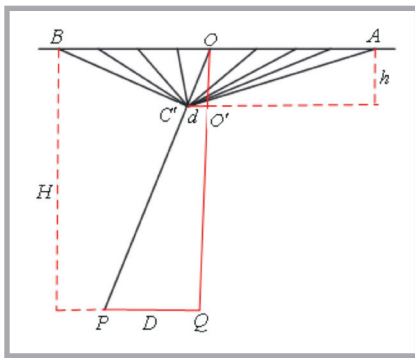

Figure 3. Diagram of measuring spinning triangle parameters.

Ring spinning system with offset device

To simulate fibre tension distribution in the spinning triangle and illustrate the effect of the horizontal offset $|d|$ on yarn quality, 32^s cotton yarns were spun on an EJM128 ring spinning machine with a pair of offset devices invented by our group.

As shown in Figure 2, a pair of locating yarn rounds is incorporated into a conventional ring frame, which is installed between the front roller and yarn guide and can be moved in the scale locating slot freely in order to change the horizontal offset $|d|$ continuously.

Spinning yarn and observation of the spinning triangle

In order to illustrate the effect of variations in the horizontal offset $|d|$ on yarn quality, three types of 32^s cotton yarns were spun with the locating point of the locating yarn round at the origin, right and left, respectively. For all yarns, a constant twist multiplier of 825 t.p.m. was adopted.

A diagram of measuring the spinning triangle parameters is shown in Figure 3. Here, C' is the twisting point, Q the origin of the scale locating slot, P - the locating point of the locating yarn round, D - the movement distance of the locating point, the value of which can be obtained from the scale locating slot, H the height from the front roller nip to the locating point, the value of which can be measured directly, and $|d|$ and h are the horizontal offset and height of the spinning triangle, respectively. In Figure 4, it is shown that we can change the horizontal offset $|d|$ continuously by moving the locating point of the locating yarn round P , and we can get the following equation:

$$\frac{d}{D} = \frac{h}{H} \quad (9)$$

To obtain the height of the spinning triangle h , a high speed camera should be applied. In the experiment, a high speed camera system - OLYMPUS i-speed3 was set up above the transparent roller and used to capture the geometry of the spinning triangle.

Results and discussions

In the experiment, three types of 32^s cotton yarns were spun with the locating point of the locating yarn round at the origin, right and left, respectively. An image of the spinning triangle captured in the normal position of the locating point ($d = 0$) is shown in Figure 4. After some measurements and calculations, we can get the parameters of the spinning triangle as follows:

$$\begin{aligned} H &= 15 \text{ cm}, \\ m &= 1.55 \text{ mm}, \\ h &= 2.74 \text{ mm} \end{aligned} \quad (10)$$

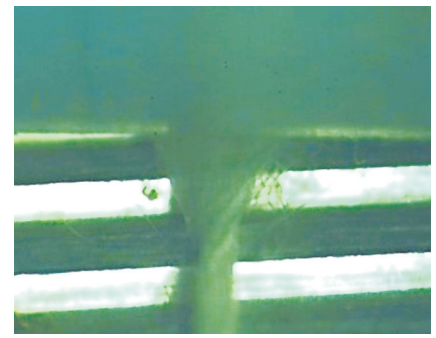

Figure 4. Image of the spinning triangle capturing by a high speed camera.

In order to get numerical simulation results of the distribution of the fibre tension at the spinning triangle, the spinning parameters and fibre properties of 32^s cotton yarns were denoted as follows: yarn spinning tension $F_s = 20$ cN, fibre Young's modulus $E = 50$ cN/tex, number of fibres in the yarn $2n + 1 = 123$, fibre linear density $A = 0.15$ tex, and the twist direction 'Z'.

By using Matlab software, the numerical simulation result of the fibre tension distributions at the spinning triangle with the horizontal offset $|d|$ varying continuously were obtained in Figure 5. Here the x-axis denotes the fibre position at the front roller nip; the negative number indicates the corresponding fibre number on the left side, the y-axis denotes the horizontal offset d , the negative value indicates the left offset, the z-axis denotes the fibre tension; the negative value indicates the compressive force, and the positive value indicates the tensile force. Generally the distribution of fibre tension is symmetrical at about $x = 0$ because we suppose that the height of the spinning triangle h is constant with the varying of

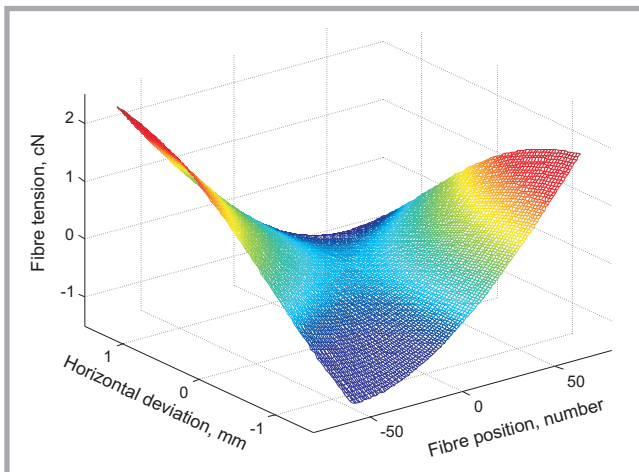

Figure 5. Fibre tensions with the horizontal offset varying continuously.

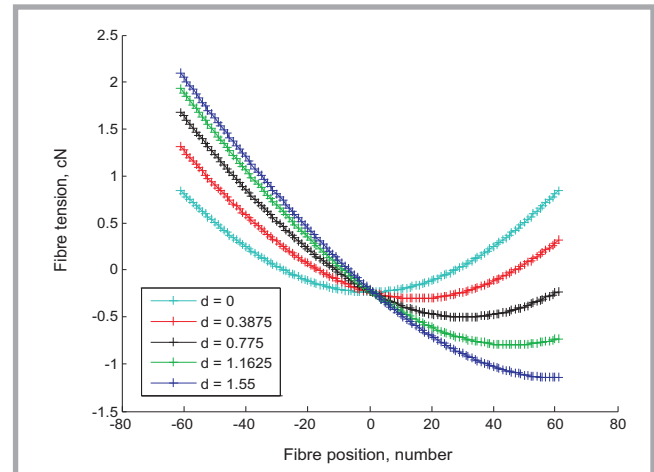

Figure 6. Fibre tensions with different horizontal right offsets.

the horizontal offset $|d|$. The fibre tension distribution is mainly dependent on the shape parameter of the spinning triangle. Along the width of the spinning triangle, different fibres have different tensions depending on their positions at the spinning triangle. As shown in **Figure 5**, the magnitude of fibre tensions is different with the varying of the horizontal offset $|d|$, and with an increase in the horizontal offset $|d|$, the magnitudes increase. To illuminate this phenomenon, the distributions of fibre tension are shown in **Figure 6** for $d = 0$ mm, $d = 0.3875$ mm, $d = 0.775$ mm, $d = 1.1625$ mm and $d = 1.55$ mm, respectively. Fibre tensions at the five horizontal offsets have different magnitudes, ranging from -0.2362 to 0.8455 cN, -0.3059 to 1.3109 cN, -0.5029 to 1.6765 cN, -0.7963 to 1.9329 cN, and 1.1483 to 2.0910 cN, respectively.

As shown in **Figure 6**, the fibre tension distribution with $d = 0$ is symmetrical about line $x = 0$. With an increasing in the horizontal offset $|d|$, the tension force decreases for fibres on the right side of the spinning triangle, whereas it increases for fibres on the left side. In fact, for fibres on the right side, the curves are under compressive forces for $d = 0.775$, $d = 1.1625$ and $d = 1.55$, but a part of fibres are under tensile loading for $d = 0$ and $d = 0.3875$.

To illustrate the influence of the fibre tension distribution on yarn properties, three types of 32^s cotton yarns were spun with the locating point of the locating yarn round P at the origin $D = 0$ cm, right $D = 6.8$ cm and left $D = -6.8$ cm respectively. After calculation using **Equation 9**, we get $d = 0$ mm, $d = 1.224$ mm and $d = -1.224$ mm correspondingly. The numerical simulation results of the fibre tension distributions at the spinning triangle with these three horizontal offsets are shown in **Figure 7**. We can observe that the distributions of fibre tension with $d = 1.224$ mm and $d = -1.224$ mm are symmetrical about $x = 0$. The measured properties of the spun yarns produced under the three horizontal offsets are shown in **Tables 1 - 3**.

Hairiness is one of most important properties of spun yarn. From **Table 1**, it is evident that spun yarn with a right offset has less hairiness than the normal yarn. However, spun yarn with a left offset has 1 ~ 4 mm less hairiness; however, it has 5 ~ 9 mm more hairiness than normal yarn. Compared with spun yarns with a left offset, that with a right offset also has

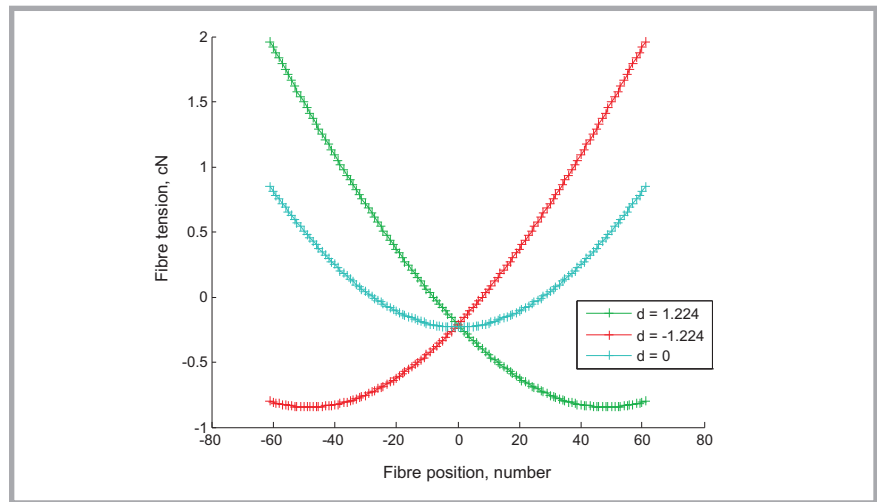

Figure 7. Fibre tensions with two different horizontal offsets.

Table 1. Hairiness of three kinds of yarn.

Hairiness length, mm	Normal ring yarn	Ring yarn with left offset	Reduction ratio, %	Ring yarn with right offset	Reduction ratio, %
1	924.6	872.5	-5.63	861.5	-6.82
2	219.3	212.3	-3.19	199.9	-8.85
3	62.6	60.3	-3.67	55.8	-10.86
4	23.3	21.0	-9.87	20.1	-13.73
5	10.1	11.8	+16.83	8.8	-12.87
6	4.8	6.2	+29.17	4.8	-0
7	2.6	4.0	+53.85	2.5	-3.85
8	1.7	2.1	+23.53	1.2	-29.41
9	1.2	1.3	+8.33	0.8	-33.33

Table 2. Strength of three kinds of yarn.

Yarn strength index		Normal ring yarn	Ring yarn with left offset	Ring yarn with right offset
Breaking time, s	AV	4.56	4.84	4.70
	CV%	1.8	1.9	2.5
Tenacity, cN/tex	AV	24.2	23.1	26.2
	CV%	1.2	2.2	2.9
Elongation at break, %	AV	7.5	8.0	7.8
	CV%	1.2	2.2	2.9
Breaking work, cN.cm	AV	657.7	674.3	719.1

Table 3. Evenness of three kinds of yarn.

Yarn evenness index		Normal ring yarn	Ring yarn with left offset	Ring yarn with right offset
CV%	mean	11.62	11.00	11.45
Thin, -50% 1000 m ⁻¹		0	0	0
Thick, +50% 1000 m ⁻¹		3	3	0
Neps, +200% 1000 m ⁻¹		10	3	7

1 ~ 4 mm less hairiness. In other words, appropriate right offset of the spinning triangle can help to reduce spun yarn hairiness with a 'Z' twist. Combined with the numerical simulation result shown in **Figure 7**, we can draw the following conclusion: selecting an appropriate right offset of the spinning triangle can help to reduce spun yarn hairiness with a 'Z' twist, whereas an appropriate left offset

can help to reduce spun yarn hairiness with an 'S' twist. This conclusion will be verified in our further studies.

Yarn strength is another of the most important properties in evaluating yarn performance. As shown in **Table 2**, yarns with a right offset have higher levels of breaking strength than normal yarns, whereas yarns with a left offset have

lower levels with a 'Z' twist. One possible explanation of this phenomenon is that an appropriate right offset of the spinning triangle can help to transfer the twist uniformly, thus benefitting the tension balance between the left and right fibre, which may reinforce yarn strength by increasing the lateral pressure between fibres. In addition, it is noted that yarn elongation changes little with the varying of the horizontal offset.

In addition, it is noted that spun yarns with both an appropriate right and left offset exhibit better yarn evenness than normal yarns.

In other words, selecting an appropriate right offset of the spinning triangle can help to improve spun yarn quality with a 'Z' twist. One possible explanation of this phenomenon is that when 'Z' twisting is inserted into fibres in the spinning triangle, there is pretension on the fibres on the right side, whereas the fibres on the left side are relatively loose (see **Figure 4**). With an increase in the right horizontal offset d , the tension force increases for fibres on the left side of the spinning triangle, whereas there is a decrease for fibres on the right side (see **Figures 6** and **7**), i.e., selecting an appropriate right offset can help to strengthen the control of fibres on the left side. However, yarn quality is not always improved with an increase in the offset. As shown in **Figure 7**, with an increase in the horizontal offset, the tension of the outer fibres increase fast; when the fibre tension increases to a certain degree and exceeds the maximum tolerance of the fibre, it will break and thus not benefit yarn quality. Therefore the optimal horizontal offset will be investigated in our further study.

Conclusions

In this paper, the effects of the horizontal offset d of the ring spinning triangle on yarn qualities has been investigated. By taking point O as the origin, with the horizontal offset d having a positive value with a right offset, which has a negative one with the corresponding left offset, and using the principle of minimum potential energy and the results in [4], the distribution of fibre tension in the spinning triangle with both the right and left offsets have been presented uniformly. Then, as an application of the method proposed, spinning triangles of a modified ring spinning system with a pair of

offset devices which can change the horizontal offset d continuously have been studied. The fibre tension distributions in the spinning triangle are simulated numerically with the horizontal offset varying continuously on the assumption that the height of the spinning triangle h is constant. It is noted that with an increasing in the right (left) horizontal offset $|d|$, the tension force decreases for fibres on the right (left) side of the spinning triangle, whereas it increases for fibres on the left (right) side; consequently, the magnitudes increase. Furthermore the properties of spun yarns produced by the modified system are evaluated and analysed by using the simulation result. We know that selecting an appropriate right offset of the spinning triangle can help to improve spun yarn quality with a 'Z' twist. However, the yarn quality is not always improved with an increase in the offset. Therefore the optimal offset will be investigated in our further study.

Acknowledgments

This work was supported by the National Natural Science Foundation of P. R. China under Grant 11102072, Fundamental Research Funds for Central Universities JUSRP21104 and Innovation projects of Science and technology enterprises in Northern Jiangsu SBC2010460.

Reference

- Zhang Wengeng, Chen Mingyou, Ding Shouji, Peng Weilian. *The basic theory of the twisting process*. Textile Engineering Publishers, Beijing, 1983.
- Hua Tao, Tao Xiaoming, Cheng Kwok Po Stephen, Xu Bingang. Effects of Geometry of Ring Spinning Triangle on Yarn Torque Part I: Analysis of Fibre Tension Distribution. *Textile Research Journal* 2007; 77(11): 853-863.
- Hua Tao, Tao Xiaoming, Cheng Kwok Po Stephen, Xu Bingang. Effects of Geometry of Ring Spinning Triangle on Yarn Torque: Part II: Distribution of Fibre Tension within a Yarn and Its Effects on Yarn Residual Torque. *Textile Research Journal* 2010; 80(2): 116-123.
- Feng Jie, Xu Bingang, Tao Xiaoming, et al. Theoretical Study of Spinning Triangle with Its Application in a Modified Ring Spinning System. *Textile Research Journal* 2010; 80(14): 1456-1464.
- Wang Xungai. Recent research on yarn hairiness testing and reduction: Part-Reduction of Yarn Hairiness. *Research Journal of Textile and Apparel* 1998; 3(1): 1-8.
- Thilagavathi G, Udayakumar D, Sasikala L. Yarn hairiness controlled by various left diagonal yarn path offsets by modified bottom roller flute blocks in ring

- spinning. *Indian Journal of Fibre and Textile Research* 2009; 34: 328-332.
- An Xianglong, Yu Chongwen. Dynamic model of sirospun process. Part I: theoretical dynamic model. *Journal of the Textile Institute* 2010; 101(9): 805-811.
- Cheng Longdi, Fu Peihua, Yu Xiuye. Relationship between hairiness and the twisting principles of solospun and ring spun yarns. *Textile Research Journal* 2004; 74(9): 763-766.
- Momir N, Zoran S, Franc L, Andrej S. Compact Spinning for Improved Quality of Ring-Spun Yarns. *Fibres & Textiles in Eastern Europe* 2003; 11(4): 30-35.
- Ren Liang. A new idea to reduce ring spinning yarn hairiness-mismatch spinning. *Shang Hai Textile Science & Technology* 2009; 37(3):16-17, 25.
- Ren Liang, Chen Jingkun, Fan Guangcai, Song Qinjie, Liu Guoqi. Mismatch Spinning to Reduce Ring Spinning Yarn Hairiness. *Progress in Textile Science & Technology* 2009; 2: 39-40.
- Tao Xiaoming, Xu Bingang, Wong Sing-kee Eric. *Manufacturing Method and Device for Producing Singles Ring Spun Yarns*. International Publication No: WO2006/074582, 2006.
- Xu Bingang, Tao Xiaoming. Techniques for Torque Modification of Singles Ring Spun Yarns. *Textile Research Journal* 2008; 78(10): 869-879.
- Yang Kun, Tao Xiaoming, Xu Bingang, Jimmy Lam. Structure and Properties of Low Twist Short-staple Singles Ring Spun Yarns. *Textile Research Journal* 2007; 77(9): 675-685.
- Fujino K, Uno M, Shiomi A, Yanagawa Y, Kitada Y. A Study on the Twist Irregularity of Yarns Spun on the Ring Spinning Frame. *The Textile Machinery Society of Japan* 1962; 8: 51-62.
- Pavlov YV. Structural Transformations in the Fibre Assembly at the Twist Threshold at the Instant of Rupture. *Technology of the textile industry* 1965; 4: 57-63.
- Krause HW, Soliman HA, Tian JL. Investigation of the Strength of the Spinning Triangle in Ring Spinning. *Melliand Textilberichte* 72: 499-502, 1991.
- Klein W. Spinning Geometry and its Significance. *International Textile Bulletin: Yarn Fabric Forming* 1993; 139: 22-26.
- Wang Xungai, Chang Lingli. Reducing Yarn Hairiness with a Modified Yarn Path in Worsted Ring Spinning. 2003; 73(4): 327-332.
- Shaikhzadeh NS. *An Analysis of the Twist Triangle in Ring Spinning*. PhD Thesis, University of New South Wales, Australia, 1996.
- Li Shengyan, Xu Bingang, Tao Xiaoming. Numerical Analysis on Mechanical Behavior of a Ring-Spinning Triangle Using the Finite Element Method. *Textile Research Journal* 2011; 81(9): 959-971.

Received 07.06.2011 Reviewed 14.11.2011