

Mehmet Topalbekiroğlu,  
Ali Kireççi,  
\*L. Canan Dülger

Department of Textile Engineering,  
E-mail: tbekir@gantep.edu.tr,  
kirecci@gantep.edu.tr

\*Department of Mechanical Engineering,  
Faculty of Engineering,  
University of Gaziantep,  
27310 Gaziantep, Turkey  
E-mail: dulger@gantep.edu.tr

# Design of a Warp Control Mechanism for Handmade Carpets

## Abstract

An electromechanical warp control mechanism (WCM) with a positioning mechanism, whose drive system is used in the production of handmade carpets, was designed and implemented in this study. It performs the function of controlling and preparing a pair of warp yarns for a knotting mechanism. The knotting mechanism is a basic mechanism forming the knots used in handmade carpets. The positioning mechanism is also used to control the motion of the WCM forwards and backwards in the width direction of the loom. The movement of the weaver hand is taken as a realistic model for controlling the warp yarns since the knots are produced independently from each other. A model of the WCM was designed and manufactured. Its dimensions were determined using a graphical method. Finally, its construction and control details are given and discussed herein.

**Key words:** handmade carpet, Turkish knot, warp control mechanism, dimensional synthesis.

## Introduction

Carpet weaving is a very ancient tradition of many cultures. At present, the carpet market is still an important branch of industry. Carpets are used in houses as floor coverings, blankets, tablecloths and for decoration purposes. The term carpet means one type of thick fabric equipped with extra yarn on its surface, which is termed the pile [1 - 3]. In producing the fabric, two sets of yarns, which traverse each other at right angles, are used. The first set extends in the length wise direction of the fabric, known as the warp, while the other set of yarns, called the weft, extends across the width. The pile of a carpet is produced with the support of the warp and weft, inserting or bonding extra yarn into the base fabric and knotting extra yarn on two warp pairs.

In general, carpets are mainly categorised into two groups by looking at their weaving type: handmade and machine carpets [1 - 7]. Their weaving structures can be a pile weave or fancy weave, including a plain or twill construction to produce a flat surface on the carpet. The main difference between handmade and machine carpets is their texture type. Texture is created by the size and twist of the yarns, as well as by the surface of the finished carpet. The texture of a machine carpet is in the form of loops in the shape of the letter 'u', shown in *Figure 1.a* [5, 7]. However, the texture of handmade carpets is formed from independent knots, for example the Turkish knot (Gördes) and the Persian knot (Sehna), which are shown in *Figure 1.b* and *Figure 1.c* [1, 2, 4 - 7]. The pile surface of machine carpets is produced by the Jacquard mechanism, whereas in handmade carpets it is produced by the weaver.

Machine carpets have some advantages over handmade ones; their rapid production and lower cost can be given as an example. However, their shorter product life, poor knot profile and low number of knots per centimetre square are the main disadvantages. The knot profile requires binding the underside of machine carpets using special glue. Handmade carpets, on the other hand, offer better resilience, an extraordinary knot profile, a higher number of knots per centimetre square, a high commercial value and long life. But they do represent an expensive choice since their production times are longer [7].

Handmade carpets are the most original work of art in Turkish arts and craftsmanship. Each handmade carpet is original and unique. They may be similar in design but one is never exactly the same as the other. The weaving methods of handmade carpets have not changed for several hundred years. Only the structures of the looms for handmade carpets have a little change over time. The most important reason is that the weaving process consists of independent knots and requires a very complex mechanism to tie them. However, technological developments (computer, hardware, software, and actuators such as the stepper motor, servo motors and so on) have made it possible to design machines for different purposes.

This article presents part of a study detailing the electromechanical production of handmade carpets, which includes the design, construction and control of a WCM with a positioning mechanism. This mechanism serves to distinguish a pair of warp yarns from others and separate them from each other at a certain distance. A realistic model of the WCM is

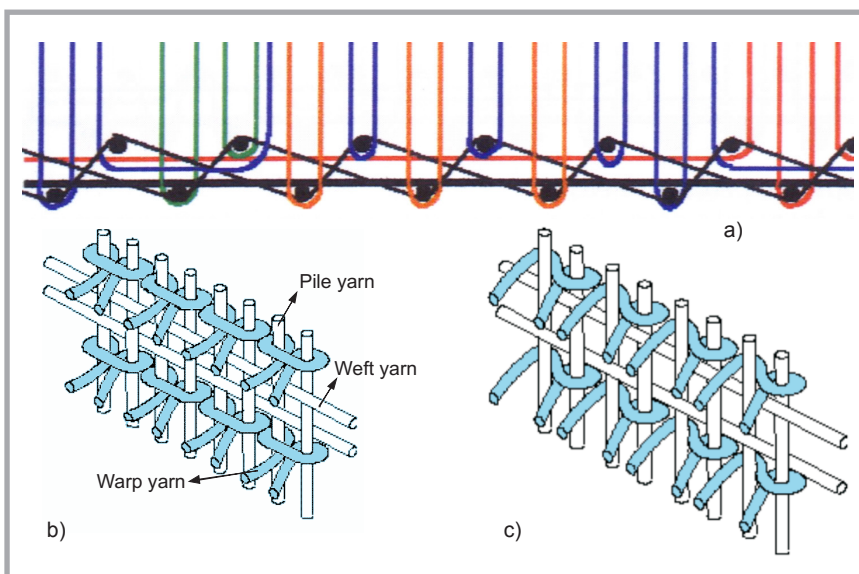

**Figure 1.** Types of carpet knot profiles; a) machine carpet knots, b) turkish handmade knots, c) persian handmade knots [1, 2, 4 - 7].

studied. The movement of the weaver's hand is taken as a model for controlling the warp yarns, and the knots are produced independently from each other.

## Literature survey

Few studies exist in the available literature on the development of looms for handmade carpets. Kireççi et al [4] offered an alternative solution for producing Turkish knots in a handmade carpet. Kireççi et al [5] analysed the design of an electro-mechanical loom to produce carpets with Gördes knots using the advantages of technological developments. Topalbekiroğlu et al [6, 8, 9] worked on a pattern used in handmade carpets. A computer controlled mechanism was designed to prepare pile yarn according to the colour code and knotting mechanism. Topalbekiroğlu [7] designed and constructed a computer controlled knotting system that aimed to produce the Turkish knot, which is the basic knot type used in handmade carpets. It was performed as part of a National Research Project. (Topalbekiroğlu et al [10] studied the design and construction of a mechanism to control warp yarns for handmade carpets. Topalbekiroğlu *et. al.* [11] then presented a study of weaving 'Turkish knots' in handmade carpets using an electro-mechanical system. Topalbekiroğlu et al [12, 13] later performed a kinematic analysis of a beat-up mechanism for handmade carpet looms. A crank-rocker type four-bar mechanism was selected for the beat-up mechanism, a dynamic analysis of which was performed to determine the beat-up force and loads on the joints. Çelik et al [14] presented beat-up mechanisms for handmade carpet looms, in which different alternative mechanisms that can perform the process of inserting the weft thread and knots into the carpet were presented. Chaudhary et al [15] studied an optimal design for the weaving loom structure of an Indian carpet. Optimisation of the metallic loom was carried out, resulting in a relatively lightweight carpet and reduced cost.

## Design of the warp control mechanism

The design of an electromechanical system to prepare and control the pair of warps used for handmade carpets is presented in this section. This mechanism is referred to as 'the warp control mechanism'. Here, the problem is to design and create a WCM to serve the functions of

preparing a pair of warp yarns by distinguishing them from other pairs, and to separate this pair from the others by a certain distance in a knotting system including the knotting mechanism with a vacuum unit, the warp control mechanism, the pile yarn manipulating mechanism including the pattern study, as well as the pile yarn holding, cutting and knotting mechanisms to produce the Turkish knots. **Figure 2** shows the positioning of all the mechanisms during the knotting process as well as the position of the WCM and the trajectory of the pair of warp yarns which will be separated from the others. The trajectory is indicated as a dashed line, and the dashed box in the same figure represents the location of the WCM.

The design specifications are given as follows: (i) the WCM should have a simple structure and be compact in size; (ii) the WCM should be designed in accordance with the knotting mechanism; (iii) the WCM must distinguish a pair of warp yarns from the others and separate them from others at a certain distance by following the trajectory in **Figure 2**; (iv) the WCM should be able to move forwards and backwards, providing bi-directional control.

## A model of the WCM

A model of the WCM was designed based on the above criteria and is shown in **Figure 3**. This mechanism consists of a shaft, a right circular cone, a pneumatic piston,

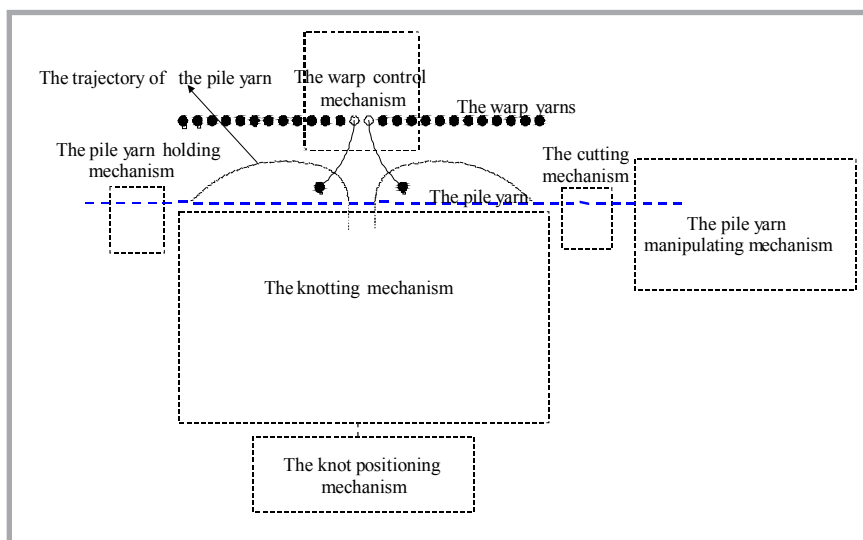

Figure 2. The warp control mechanism [7, 10].

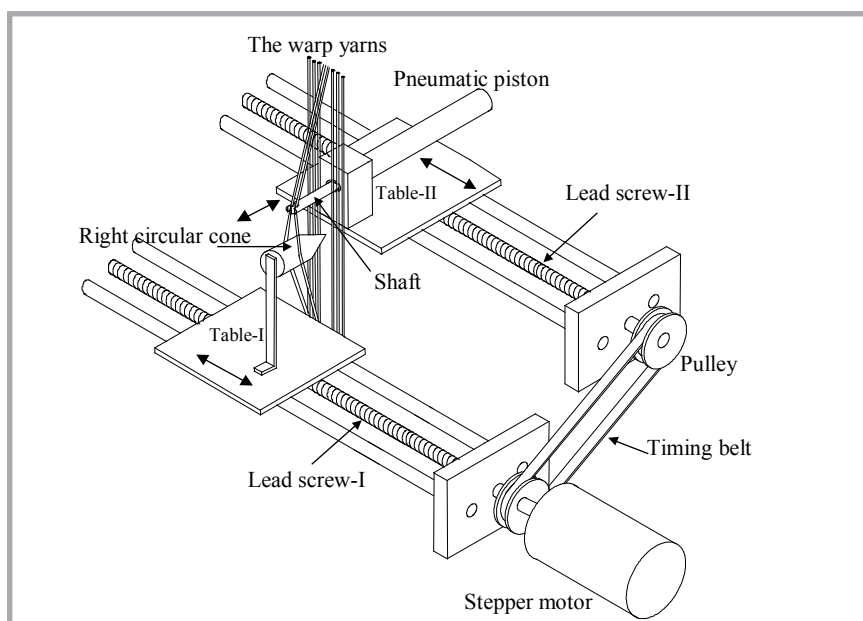
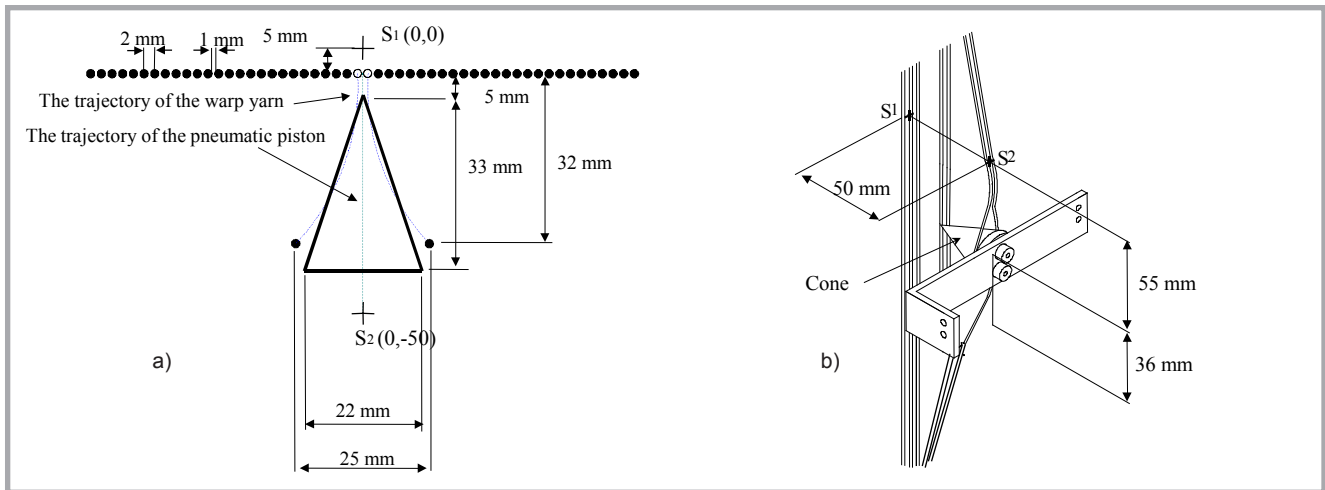

Figure 3. The warp control mechanism [7, 10].



**Figure 4.** Schematic drawings of the warp control mechanism; a) Top view, b) Isometric view.

two lead screws with supporting tables, two pulleys, a timing belt and a stepper motor. The shaft is connected to the ram of the piston that catches a pair of warp yarns by its forward motion. The cone is designed to separate this warp pair from the others, as shown in **Figure 3**. Two lead screws of the same pitch are connected to each other with a timing belt to have the same displacement. A stepper motor is used to drive the two lead screws. The position of the WCM is then controlled. When the mechanism reaches the desired position, the shaft is driven forward by the pneumatic piston. The pair of warp yarns is then distinguished from the others. They are separated at a certain distance by the right circular cone at the end of the forward motion of the piston. The shaft is driven backwards when the knot formation is completed by the knotting mechanism.

#### Dimensions of the WCM

The dimensions of the model are determined by a graphical method. Some geo-

metrical parameters are required to determine the dimensions of the mechanism. Firstly, the mechanism is drawn schematically, and then some critical distances, such as the distance between warp yarns, and the length of the pile yarn are defined. The remaining distances are then decided. These schematic drawings are given with the design specifications in **Figure 4** [7, 10].

- i. The tracing points on the trajectory for the mechanism in **Figure 4.a** are taken:  $S_{1x} = 0.0$  mm,  $S_{1y} = 0.0$  mm,  $S_{2x} = 0.0$  mm, and  $S_{2y} = -50.0$  mm, with respect to the x-y co-ordinate system.
- ii. The distance between a pair of warp yarns and the others is 32 mm, and the distance between this pair is 25 mm.
- iii. A right circular cone of 33 mm height and 11 mm radius should be used to separate the pair of warp yarns.
- iv. The distance between two warp yarns is taken as 1 mm.

- v. The distance between the trajectory of the piston and the cone is 55 mm. The distance between the cone and plane of the knotting mechanism is also 36 mm.

#### Construction of the WCM

Construction details of this mechanism are presented in **Figure 4**. This mechanism distinguishes a pair of warp yarns from the others and prepares them for knotting. The mechanism consists of a shaft, two cylindrical supporting rods, a right circular cone, an aluminium base plate and a pneumatic cylinder. The mechanism is controlled by the pneumatic cylinder with a 50 mm stroke. The shaft is directly connected to the cylinder with a specially designed end to push the warp yarns forward. The cylinder piston is guided by two small rods to prevent its rotation in the axial direction. A cone made of Teflon, called 'the separator', is placed in front of the piston to separate warp yarns easily, as shown in **Figure 5**.

A positioning mechanism is required to move the WCM forwards and backwards in the width direction of the loom. A positioning mechanism was designed and manufactured, as shown in **Figure 5** [7, 10]. This mechanism coordinates the movements of the WCM with respect to each warp yarn.

#### The experimental set-up

The design of the WCM included the design and construction of a prototype to produce handmade carpets mechanically. This study was completed as part of a research project. The prototype is already available at the Textile Eng. Dept

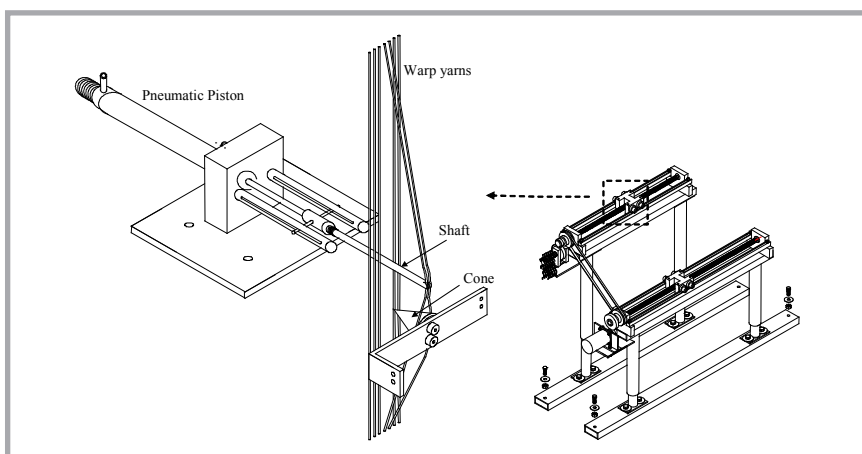

**Figure 5.** Isometric drawing of the warp control and positioning mechanisms.

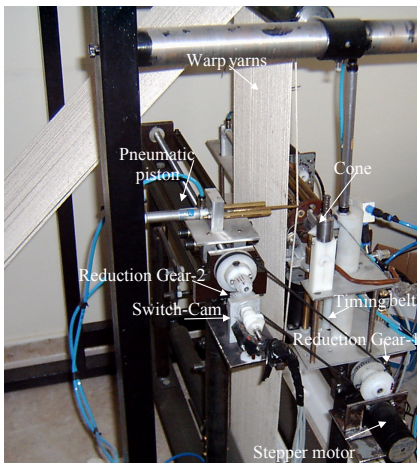

Figure 6. Photograph of the warp control mechanism.

of Gaziantep University. The study can be divided into two parts. The first part especially focuses on the knotting system, including the pile yarn manipulating mechanism, the knotting mechanism and the WCM to form the Turkish knot [7]. The second part is necessary for shedding, picking, beating-up, letting-off and taking up operations. Up to now the first part has been completed and the second part is still under construction. Some research studies have been carried out recently [12 - 14].

A photograph of the mechanism is given in Figure 6. The WCM is controlled by a pneumatic piston. The parts of the experimental set-up are given as:

- The stepper motor drive (SMC 88 Constant Current Driver) 16 bit microprocessor [16]
- A (PC/AT) compatible Pentium® II processor (400 MHz, 32 bit CPU, 64 MB RAM, and 9 GB hard disc)
- Nanotec - 1.8° - 2 Phase Four Stepper Motors (Type 4H5618C1708-A) [16]
- Stepper Motor Controller (SMC-PC) Module [16]
- Air compressor system (Puma Corporation, type PF2600/50-2.5M)
- Four 5/2 way Solenoid valves
- Pneumatic cylinder with a 50 mm stroke
- Micro Switches (Omron Corporation, Type V-152-1C5)
- Dual tracking DC power supply (6303D Series Topward).

#### Control of the WCM

A control block diagram of the mechanism is shown in Figure 7. The WCM is controlled by the pneumatic piston while the stepper motor is performing

the movement of the positioning mechanism. The operation steps of the stepper motor and pneumatic piston are sequential i.e. in a defined order for the purpose of synchronisation. A software program for a PC was developed using Delphi Programming tools to control the stepper motor. The motions of the piston and solenoid are controlled by a cam actuated by a microswitch arrangement, which is placed on the lead screw driven by the stepper motor.

The total time of operations is accepted as the unit time to form a knot. The timing diagram is represented in Figure 8, which is a graph of the operations plotted versus time. Here, the WCM distinguishes warp pairs from the others and separates them from each other within a 0.15 unit time. A carpet with dimensions of 100 cm × 150 cm was selected for testing purposes. The knot density was chosen as 26 knots in width and 33 knots in height, comprising 10 cm. The knot density is equal to that of 'Isparta carpet' [17]. The WCM was then tested for its preparation of 70 warp pairs to form a Turkish knot. Approximately, one Turk-

ish knot was made in one second by the knotting system. The WCM performs its function in 0.15 seconds during the knotting procedure. No coordination problem was observed between the mechanisms since the actuators are controlled by the computer. This mechanism is faster than a typical weaver performing a knot in 2 - 3 seconds.

#### Conclusions

A WCM with a positioning mechanism and drive system has been presented. The mechanism is used to distinguish a pair of warp yarns from the others and separate them from each other at a certain distance. A set of experiments on the mechanism was carried out to observe the real system for controlling the warp yarns. The WCM and positioning mechanisms were tested for 70 warp pairs in the frame. Seventy Turkish knots were made in 70 seconds by the knotting system. Thus, the WCM performs its function in 10.5 seconds during the knotting procedure. This mechanism is faster than a typical weaver performing 70 knots in 140-210 seconds.

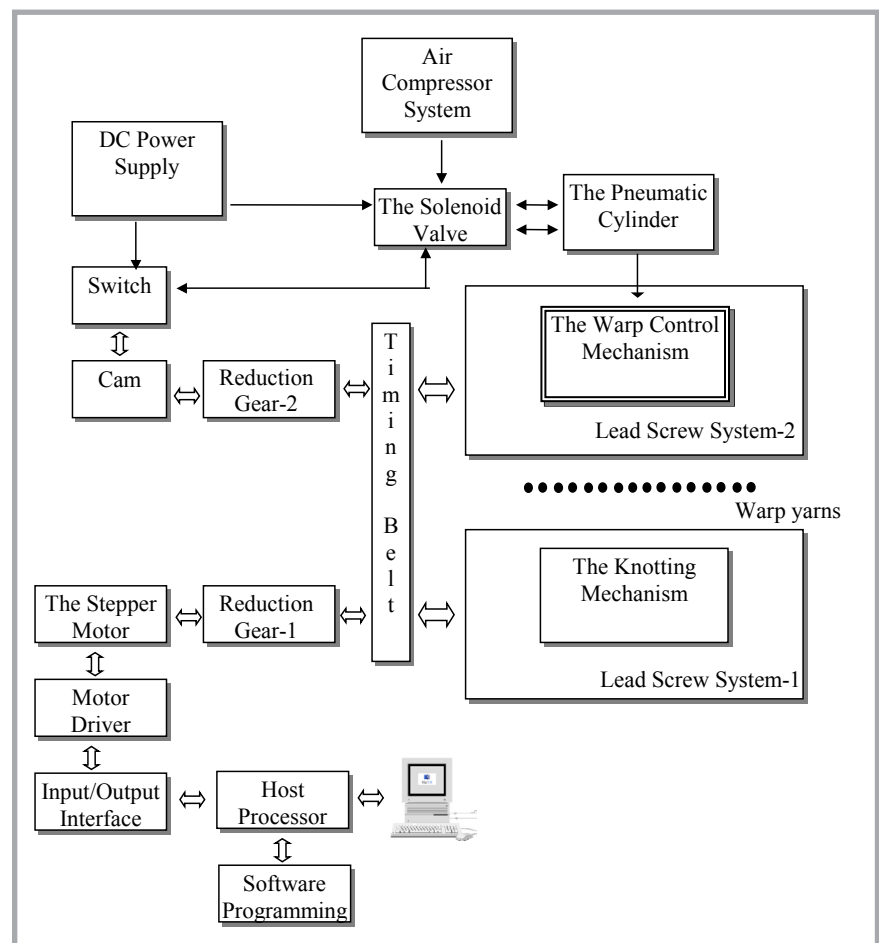

Figure 7. Control block diagram.

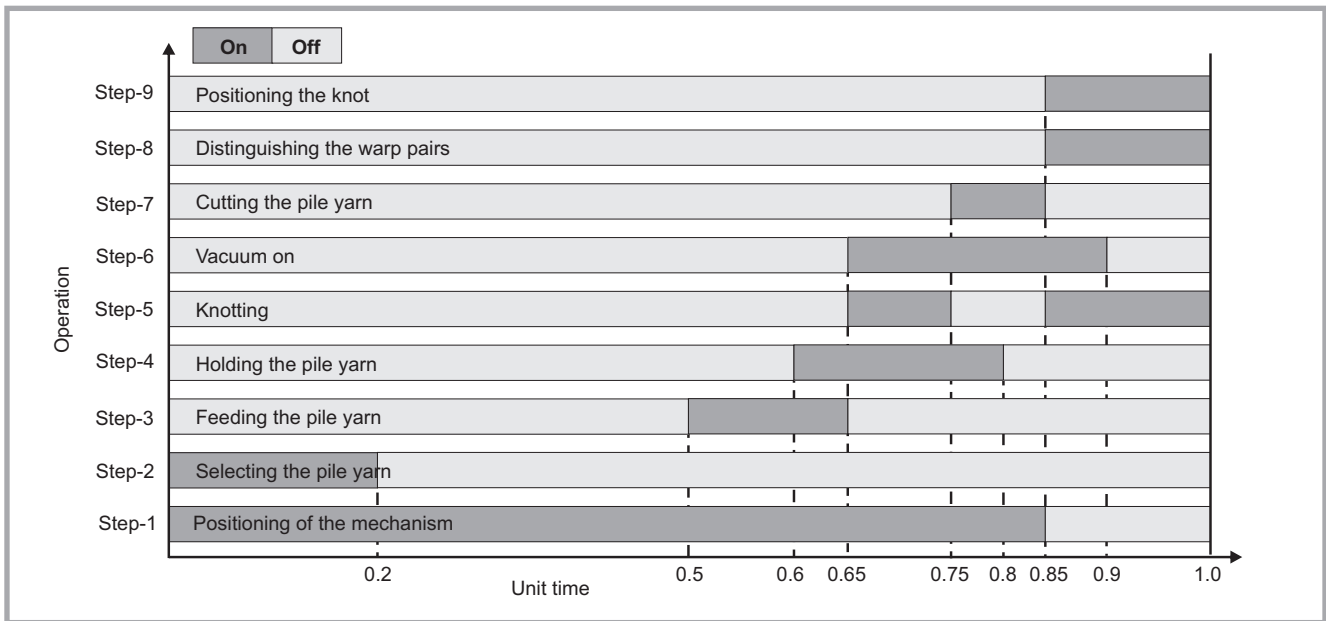

Figure 8. Timing diagram of the knotting system.

The WCM offers advantages in terms of productivity and cost. A comparison was made of distinguishing warp pairs by a weaver's hand and with this mechanism. The efficiency of the WCM in the production of carpets is increased with this solution. The prices of handmade carpets are too expensive since they are produced by weavers. This mechanism can be used for producing handmade carpets at a lower cost.

However, there are some problems: the missing of warp yarns, and friction on warp yarns was observed during the operation of the mechanism. The proper functioning and control of the mechanism depends on partially solving these problems. Misalignment on the lead screws can possibly cause jamming and serious damage to the drive systems. Friction forces between machine elements also adversely affect the functioning of the mechanisms. Improvement on the results can be made by revealing some of these problems.

## References

1. Crossland, A. *Modern Carpet Manufacture*, 1958 (Columbine Pres., Manchester & London).
2. Robinson, G. *Carpets and Other Textile Floorcoverings*, 2nd edition, 1972 (Division of Bonn Industries Inc, Trinity Press, Worcester, and London).
3. Corbman, B. P. *Textiles: Fiber to Fabric*, 1983 (The Textile Institute, Manchester)
4. Kireççi, A., Doğan, C., and Topalbekiroğlu, M. *Mechanical weaving of handmade carpets (El dokuma halılarının mekanik olarak dokunması)*. In 7. National Mechanical Theory Symposium, University of Yıldız Technical, Istanbul, Turkey, 20-22 Sept. 1995, pp.19-26.
5. Kireççi A., Dülger, L.C., Topalbekiroğlu, M. *An analysis on production of electro mechanical Gördes knot in handmade carpet (Gördes düğümlü elektromekanik halı üretiminin analizi)*. In 10. Nat. Mech. Theory Sym., Univ. of Selcuk, Konya-Turkey, 12-14 Sept. 2001, pp. 68-76.
6. Topalbekiroğlu, M., Kireççi, A., Dülger, L. C. *Computer aided pattern study and control of yarns forming patterns for hand made carpets (El halıcılığında bilgisayar destekli desen çalışması ve deseni oluşturan iplerin denetimi)*. In 10. Nat. Mech. Theory Sym., Univ. of Selcuk, Konya-Turkey, 12-14 September 2001, pp.767-775.
7. Topalbekiroğlu, M. *Design, Construction and Control of Computer Controlled Knotting System*. Ph. D. Thesis, University of Gaziantep, Gaziantep, Turkey, July 2002.
8. Topalbekiroğlu, M., Kireççi, A., Dülger, L. C. *Computer aided design of a pile yarn manipulating mechanism (El halıcılığında bilgisayar destekli hav ipi denetim mekanizması)*. *Journal of Mechanical Design and Production (Makine Tasarım ve İmalat Dergisi)*, November 2003, 5(2), 81-88.
9. Topalbekiroğlu, M., Kireççi, A., Dülger, L. C. *Design of a pile yarn manipulating mechanism*, *Proc. IMechE Part:B J. Engineering Manufacture*, Number B7, July 2005, pp. 539-546(8)
10. Topalbekiroğlu, M., Kireççi, A., Dülger, L. C. *Design and construction of a mechanism controlling warp yarns in handmade carpets (El dokuma halıcılığında çözgü iplerini denetleyen bir mekanizmanın tasarımı ve imalatı)*. *Journal of Mechanical Design and Production (Makine Tasarım ve İmalat Dergisi)*, May 2005, 7(1), 35-42.
11. Topalbekiroğlu, M., Kireççi, A., Dülger, L.C. *A study of weaving 'Turkish Knots' in handmade carpets with an electro-mechanical system*. *Proc. IMechE Part:I J. Systems and Control Engineering*, Number 15, August 2005, pp. 343-347(5)
12. Topalbekiroğlu M., Çelik H.İ., *Kinematic analysis of beat-up mechanism used for handmade carpet looms*, *Indian Journal of Fibre & Textile Research*, Vol. 34, June 2009, pp. 129-136
13. Topalbekiroğlu M., and Çelik H.İ., *Dimensional synthesis of the beat-up mechanism for handmade carpet looms (El dokuma halı tezgahları için tefe mekanizmasının boyutsal sentezi)*. In 13. National Mechanical Theory Symposium, University of Cumhuriyet, Sivas-Turkey, 07-09 June 2007, pp.223-232
14. Çelik H.İ., Topalbekiroğlu M., ve Dülger L.C., *The beat-up mechanisms for handmade carpet looms (El dokuma halı tezgahları için tefe mekanizmasının geliştirilmesi)*. In 13. National Mechanical Theory Symposium, University of Cumhuriyet, Sivas-Turkey, 07-09 June 2007, pp.203-213
15. Himanshu Chaudhary and Subir Kumar Saha, *Optimal design of an Indian carpet weaving loom structure*, *Journal of Scientific and Industrial Research*, CSIR, India, V.65, May 2006, pp. 410-415
16. *Manual SMC-PC (PP Electronic GmbH, Rimsting)*.
17. *TS 43 Textile Floor Covering- Handmade Carpets – Turkish Carpets*, 1st edition, April 1992 (Türk Standardları Enstitüsü, Ankara, Turkey).

Received 22.09.2008 Reviewed 06.10.2009