

Feng-lin Xia,  
Ming-qiao Ge

# Motion Rule of Electronically Pattern System on a High Speed Warp Knitting Machine

School of Textile & Clothing,  
Jiangnan University,  
Wuxi 214122, P. R. China

## Abstract

The linear servo control system is widely used on high speed warp knitting machines. In order to improve the characters of the electronic shogging system and decrease the impact, the principle of shogging movement is analysed in this paper, in which a trapezoidal acceleration curve is selected as the motion curve of the electronic shogging system. The parameters that affect the shogging movement are also studied. The research shows that increasing the shogging time allowed can help optimise the shogging movement. Provided that the shogging movement is secure, the shogging time can be increased as much as possible, thus improving the operational capability of the warp knitting machine.

**Key words:** high speed warp knitting machine, linear servo control, patterning mechanism, electronic shogging, motion rule, trapezoidal acceleration curve.

of the linear servo control system are a simple structure, high precision and rapidness response, hence it is widely used in the electronic shogging system on high speed warp knitting machines. The working principle and technical request of the electronic shogging system is, the proper motion rule is evaluated, and the characteristic value of the shogging movement is investigated here. The purpose of this research is intended to improve the mechanical performance and decrease the motion impact [1], then the system can be adapted to the high speeds and high precision request of a warp knitting machine.

## Motion character of the electronic shogging system on high speed warp knitting machines

### Working principle of the electronic shogging system

The electronic shogging system is mainly made up of a control unit, driven unit,

feedback unit and main shaft signal unit. **Figure 1** shows its control and structural principle. The control unit contains a computer (with touch screen), CAN-Bus and motion control cards. The driven unit contains drivers and linear servo motor. The feedback unit contains the feedback system for the linear motor and raster system. The main shaft signal unit consists of a rotary encoder and approaching switch.

Pattern data is inputted to the computer by floppy disk, USB disk or network. After processing, the data is sent to the control cards by CAN-Bus. When the machine starts to work, the control card will receive a signal from the main shaft of the machine and get the corresponding pattern data. The card can also send instructions to the servo drives, whose motor drives the guide bar. The position of the motor is transformed into a position impulse signal by an inner rotary transformer or encoder, whose signal is sent to the servo drive as a feedback signal. In the meantime, the actual displacement

## Introduction

Warp knitted fabric is characterised by small batches, many categories, a short cycle and strict requirements for pattern design. What is more, long with the development of computer and servo control technology, the electronic shogging system has become the tendency for warp knitting machines. The main advantages

**Figure 1.** Principle of electric Shogging control system on High speed warp knitting machine.

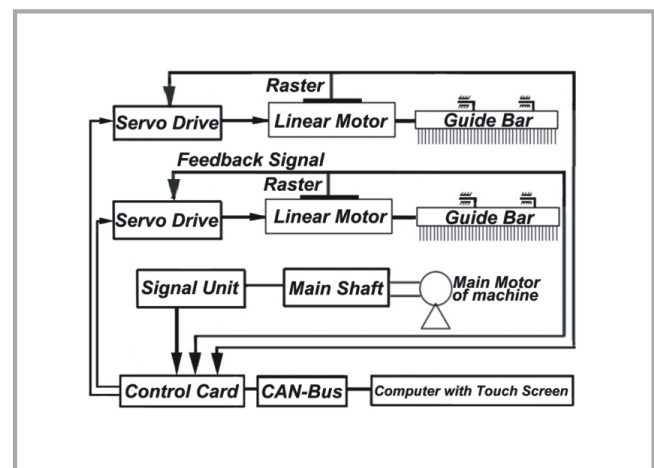

is transmitted to the servo drive and control card by a raster installed in the output axle of the liner motor. The difference between the actual position and enactment will be compensated by the control procedure so that the system can achieve high precision.

### Analysis of features of the electronic shogging system

In the loop forming course on a warp knitting machine, the guide bar should swing in the needle space so that the guide finger can carry out the overlap and underlap smoothly. After going through the needle space, the guide bar should stop the shogging movement to make sure that guide needles will not collide with the compound needles [2]. The result is that the shogging movement of the guide bar should be a “stop-move-stop” process. Thus, a precise shogging movement is a must here, especially at high speeds and fine gauge. To realise this highly precise movement, a curve with an excellent dynamic feature must be incorporated here, maintaining good stability within the shogging movement.

Take the *RSE 5 EL* machine (Gauge E32) as an example. On inspection, for one revolution of the main shaft of the machine, we can find that the angles of Guide-bar (in short GB)1-GB5 for overlap are available individually: 1.08 rad, 1.85 rad, 2.41 rad, 2.93 rad and 3.37 rad; the angles of GB1-GB5 allowed for underlap are 4.33 rad, 3.68 rad, 3.30 rad, 2.72 rad and 2.22 rad. This means that the time of GB1 allowed is shortest for the overlap, which is also the same for GB5 with respect to the underlap: 1.08 rad and 2.22 rad, respectively. The time allowed for overlap and the average acceleration can be evaluated from the following formula:

$$t = \frac{60\theta}{2\pi\omega} \quad (1)$$

$$\bar{a} = \frac{nD}{t^2} \quad (2)$$

where:

- $t$  is the time allowed for shogging, s;
- $\omega$  is the main shaft speed of the machine, r/min;
- $\theta$  is the angle allowed for overlap, rad;
- $n$  is the number of shogging needle gaps;
- $D$  is the distance between closer needles, m, which for E32 is  $7.94 \times 10^{-4}$  m;

$\alpha$  is the average acceleration of shogging,  $m/s^2$ .

The maximum speed of the main shaft of the machine is 1750 r/min [3]. Thus the overlap time allowed for GB1 is 0.0059 s, where the average acceleration is  $22.81 m/s^2$  when the shogging distance is 1 needle gap. Meanwhile, the underlap time allowed for GB5 is 0.0121 s, where the average acceleration is  $21.64 m/s^2$  when the shogging distance is 4 needle gaps. It can be concluded that the overlap time is shorter than the underlap; the average acceleration for 1 overlap needle is higher than for 4 underlap needles, which means that the servo control system must react quickly and have acute localisation, ensuring that the patterning mechanism can drive the guide bar to finish the “stop-move-stop” process in a short time, otherwise yarns may be damaged, or the guide needles will collide with the compound needles.

## Selecting and analysing the guide bar motion curve of the electronic shogging system

### Selecting a guide bar motion curve for the electronic shogging system

In order to make the guide bar shog at high speeds with fine precision, the linear motor must drive the guide bar stably. This requires the motion rule controlled by the linear motor to have excellent dynamics. If a sinusoid accelerated curve or trapezoidal accelerated curve is chosen, it allows for smooth changes in accelera-

tion. For the servo control system, a trapezoidal accelerated curve (S type curve) is easy to construct [4].

A trapezoidal accelerated curve is shown in **Figure 2**. Each motion cycle can be separated into 5 parts: positive jerk, invariable acceleration, negative jerk, invariable deceleration and positive jerk deceleration. In the invariable deceleration phase, the acceleration is constant, whereas in the changeable acceleration phase,  $da/dt = J$ ,  $J$  is invariable. Acceleration is continuous at the 6 joint points, which guarantees that no rigid or soft impulses exist during the shogging movement [5]. In one cycle of this curve, the acceleration is zero at the beginning and end points, which is convenient for the “stop-move-stop” motion mode of guide bar shogging. The shogging movement is analysed using the trapezoidal accelerated motion rule below.

The time of the shogging cycle is set as  $T$ . According to the motion continuity and boundary conditions, when the time for the five sequences are valued at  $T/8$ ,  $T/4$ ,  $T/4$ ,  $T/4$  and  $T/8$ , the maximum acceleration is at its lowest level [6]. In this case, the motion formulas for the five sequences can be carried out in the following form.

#### 1. Positive jerk acceleration phase:

The time in the positive jerk acceleration phase is  $T/8$ , the corresponding formula being:

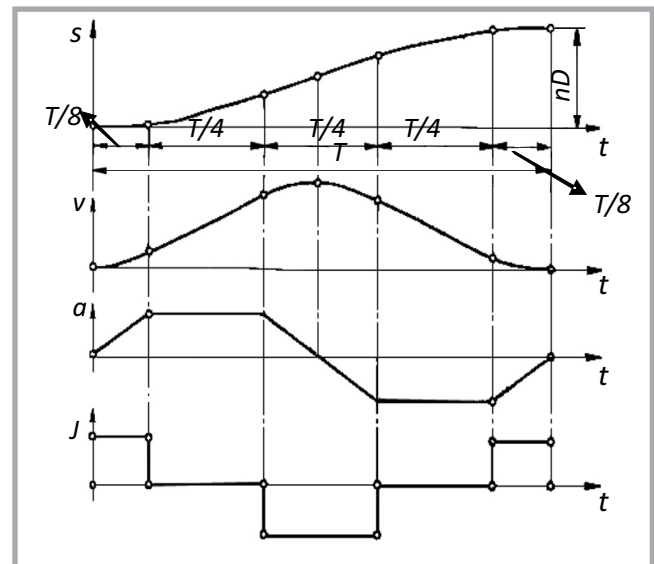

**Figure 2.** The motion rule of trapezoidal acceleration curve.

$$\left. \begin{aligned} s &= \frac{64nD}{9T^3} t^3 \\ v &= \frac{64nD}{3T^3} t^2 \\ a &= \frac{128nD}{3T^3} t \\ J &= \frac{128nD}{3T^3} \end{aligned} \right\} \quad (3)$$

where:

- $s$  is the shogging distance, m;
- $v$  is the shogging speed, m/s;
- $a$  is the shogging acceleration, m/s<sup>2</sup>;
- $J$  is the shogging jerk, m/s<sup>3</sup>;
- $n$  is the needle gaps in the shogging movement;
- $D$  is the distance between two adjacent needles, m;
- $t$  is the shogging variable,  $t \in [0, T/8]$ .

### 2. Invariable acceleration phase:

The time in the invariable acceleration phase is  $T/4$ , the corresponding formula being:

$$\left. \begin{aligned} s &= \frac{nD}{72} + \frac{nD}{3T} \left( t - \frac{T}{8} \right) + \frac{8nD}{3T^2} \left( t - \frac{T}{8} \right)^2 \\ v &= \frac{nD}{3T} + \frac{16nD}{3T^2} \left( t - \frac{T}{8} \right) \\ a &= \frac{16nD}{3T^2} \\ J &= 0 \end{aligned} \right\} \quad (4)$$

where  $t \in [T/8, 3T/8]$ .

### 3. Negative jerk phase:

The time in the negative jerk phase is  $T/4$ , the corresponding formula being:

$$\left. \begin{aligned} s &= \frac{19nD}{72} + \frac{15nD}{9T} \left( t - \frac{3T}{8} \right) + \frac{8nD}{3T^2} \left( t - \frac{3T}{8} \right)^2 - \frac{64nD}{9T^3} \left( t - \frac{3T}{8} \right)^3 \\ v &= \frac{15nD}{9T} + \frac{16nD}{3T^2} \left( t - \frac{3T}{8} \right) - \frac{64nD}{3T^3} \left( t - \frac{3T}{8} \right)^2 \\ a &= \frac{16nD}{3T^2} - \frac{128nD}{3T^3} \left( t - \frac{3T}{8} \right) \\ J &= -\frac{128nD}{3T^3} \end{aligned} \right\} \quad (5)$$

where  $t \in [3T/8, 5T/8]$ .

### 4. Invariable deceleration phase:

The time in the invariable deceleration phase is  $T/4$ , the corresponding formula being:

$$\left. \begin{aligned} s &= \frac{71nD}{72} + \frac{nD}{3T} \left( t - \frac{5T}{8} \right) - \frac{8nD}{3T^2} \left( t - \frac{5T}{8} \right)^2 \\ v &= \frac{nD}{3T} - \frac{16nD}{3T^2} \left( t - \frac{5T}{8} \right) \\ a &= -\frac{16nD}{3T^2} \\ J &= 0 \end{aligned} \right\} \quad (6)$$

where  $t \in [5T/8, 7T/8]$ .

### 5. Positive jerk deceleration phase:

The time in the positive jerk deceleration phase is  $T/8$ , the corresponding formula being:

$$\left. \begin{aligned} s &= nD + \frac{64nD}{9T^3} (t-T)^3 \\ v &= \frac{64nD}{3T^3} (t-T)^2 \\ a &= -\frac{128nD}{3T^3} (t-T) \\ J &= \frac{128nD}{3T^3} \end{aligned} \right\} \quad (7)$$

where  $t \in [7T/8, T]$ .

### Analysing the guide bar motion curve of the electronic shogging system

When the linear motor is controlled by the trapezoidal accelerated motion rule to drive the shogging movement, the shogging speed, acceleration and jerk curve are all running continuously, and the curves of speed and acceleration at the beginning and end points of shogging are zero, thus shogging stability is guaranteed. By analysing formulae (3) to (7), the position and value of the maximal speed, maximum acceleration and maximal jerk in one shogging course can be obtained.

#### Maximal speed of shogging

The maximum speed occurs at the center point of the shogging movement. Put  $t = T/2$  into formula (5):

$$v_m = 2nD/T \quad (8)$$

#### Maximum acceleration of shogging

The maximum acceleration occurs at  $t \in [T/8, 3T/8]$  or  $t \in [5T/8, 7T/8]$ . Put  $t$  into formulae (5) and (6):

$$a_m = \pm 5.33nD/T^2 \quad (9)$$

#### Maximal jerk of shogging

The maximal jerk occurs at  $t \in [0, T/8]$ ,  $t \in [3T/8, 5T/8]$  and  $t \in [7T/8, T]$ . Put  $t$  into formulae (3), (5) and (7):

$$J_m = \pm 42.67 nD/T^3 \quad (10)$$

## Optimising the shogging curve of the guide bar

### Factors influencing the shogging character

Take the *RSE 5 EL* machine (Gauge E32) as an example. Let us suppose that the number of shogging needle gaps is  $n = 1$ , the distance between closer needles  $D = 7.94 \times 10^{-4}$  m, the speed of the main shaft is 1750 r/min, and the shogging time (overlap) is 0.0059 s, then put them into formula (9), resulting that the maximum acceleration for the shogging movement is  $\pm 121.6$  m/s<sup>2</sup>. This is very high acceleration and will cause huge inertia action, which is harmful to the machine and its production. Therefore, it is essential to optimise the motion parameter of the shogging movement.

As shown in the analysis above, it can be seen that in the shogging cycle, the maximal speed, acceleration and jerk has a direct relation with the distance between closer needles  $D$ , the number of shogging needle gaps  $n$ , and has an inverse relation with the shogging time  $T$ .  $D$  is fixed on a certain warp knitting machine, and  $n$  is decided by the fabric structure.  $T$  is determined by the loop forming curve of knitting elements and the speed of the main shaft of the machine.

When a trapezoidal acceleration curve is chosen as the electronic shogging rule, the maximal speed, acceleration and jerk should be reduced in order to optimise the shogging movement. This means we can only increase the shogging time  $T$  to optimise the shogging movement. But reducing the machine speed will cause lower production, hence extending the shogging time is advisable.

### Optimised analysis of the guide bar shogging curve

During the course of loop formation, the motion of the guide needle consists of shogging and swinging. Figure 3 shows guide needle moves around the compound needle. While the guide needle is swinging in the compound needle gap, the clearance between the guide needle and compound needle is  $\Delta$ . With the yarn diameter  $d$ , we can evaluate the gap when the guide needle swings in the compound needle area using  $\delta = \Delta - d$ . Take *RSE 5 EL* machine (Gauge E32) as an example, the thickness  $a$  of the compound needle head is 0.2 mm, the thickness  $b$  of the

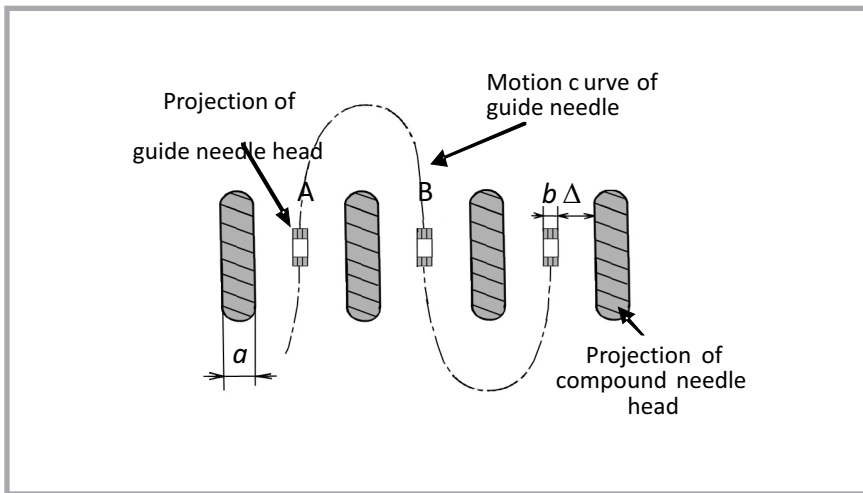

Figure 3. The sketch of the motion curve of the guide needle (laps 1 needle).

guide needle head is 0.2mm, the maximal yarn count knitted on a Gauge 32 machine is 19 Tex [7], then:

$$\delta = \Delta - d$$

$$= \frac{0.79375 - (0.20 + 0.20)}{2} - 0.03568 \times \sqrt{19}$$

$$\approx 0.041(\text{mm})$$

In order to increase the time allowed for the shogging movement of the guide bar, the method of advancing the shogging start time and putting off finishing time must be undertaken, which means the guide needles should start to shog before they swing the compound needles out. When the guide needles swing back, the shogging movement is not yet finished. However, the shogging displacement must be strictly controlled. When the guide needles arrive at position A, as shown in Figure 3, the shogging displacement should be less than  $\delta$ , otherwise the yarn may be damaged.

When  $n = 1$  and  $D = 7.94 \times 10^{-4}$  m, the displacement of the positive acceleration phase 's' is 0.011mm, and the accumulative displacement of the invariable acceleration 's' is 0.210 mm. When the displacement is  $\delta$ , then  $t \in [T/8, 3T/8]$ , by formula (4):

$$\delta \geq \frac{nD}{72} + \frac{nD}{3T} \left( t - \frac{T}{8} \right) + \frac{8nD}{3T^2} \left( t - \frac{T}{8} \right)^2$$

$$\text{Solves: } t_A \leq 0.228T \quad (11)$$

where:  $t_A$  is the  $t$  value corresponding to point A.

When the machine speed is 1750 r/min, the time of GB1 from point A to B is 0.0059 s, for which the shogging displacement curve is symmetrical, then:

$$T = 2t_A + 0.0059 \quad (12)$$

Using formulae (11) and (12):

$T = 0.0108$  s. This just means a shogging time increase of 82%.

**Take 1** shogging needle, a shogging displacement of  $D = 7.94 \times 10^{-4}$  m, an overlap time of  $T = 0.0108$  s, using formula (8) and (10): The maximal speed of the guide bar  $v_m = 0.15$  m/s, maximal acceleration  $a_m = \pm 36.28$  m/s<sup>2</sup>, maximal jerk  $J_m = \pm 2.69 \times 10^4$  m/s<sup>3</sup>.

It should be guaranteed that the shogging movement is safe i.e. the shogging displacement is less than the difference between the gap for the yarn and the yarn diameter when the guide needles arrive at position A. In this way, the time allowed for shogging can be extended and the maximal speed, acceleration and jerk can be greatly reduced. The motion performance of the guide bar can be improved.

## Conclusions

1. The guide bar shogging time of a high speed warp knitting machine is extremely short in every shogging process, being about several milliseconds only. The shogging acceleration of the guide bar is extremely great, and the motion mode of the shogging is in "stop-move-stop". In view of the servo control method, the trapezoidal ac-

celeration motion rule is available for the shogging movement on high speed warp knitting machines.

2. When the trapezoidal acceleration motion rule is chosen for the shogging movement, the maximal speed of the guide bar is in the middle position of the shogging process, the maximal acceleration is in  $1/8 \sim 3/8$  and  $5/8 \sim 7/8$  for shogging cycle, and the maximal jerk is  $0 \sim 1/8$ ,  $3/8 \sim 5/8$  and  $7/8 \sim 1$  for the shogging cycle.
3. The maximal speed, maximal acceleration and maximal jerk are related to the machine gauge, shogging time and distance. Extending the shogging time can optimise the motion of the guide bar, which means that the guide needles should start to shog before they swing the compound needle gaps out. When the guide needles swing back, the shogging movement is not finished yet. The actual shogging time is increased by 82%, and the motion character and performance of the shogging movement are improved on high speed warp knitting machines.

## References

1. Bruck S.; Feed-drive system with a permanent magnet linear motor for ultra precision machine tools. IEEE 1999 International Conference on Power Electronics and Drive Systems, Hong Kong 1999: pp 821-826.
2. Venkatraj R.; Warp Knitting Machines[J]. Indian Textile Journal; Feb. 1999, Vol. 109 Issue 5, pp. 22-23.
3. Mayer K.; Fabric Special Designed for Woman [J]. Kettenwirk Praxis, 2005, (3): pp. 12-13.
4. www.baumueller.de.
5. Jiang-hong GAO; Design on the motion law of follower component of cam mechanism[J]. Journal of Machine Design, 2006, 23(2): pp. 45-47.
6. Yong-gang SHI, Yang-fang W. U.; Design of Cam Mechanism and Application Innovation[M]. Beijing: China Machine Press, 2007: pp. 22-53, 204-248;
7. Raz S.; Warp Knitting Production[M]. Melliland Textilberichte GmbH, Heidelberg, 1987: pp. 493-499.

Received 09.11.2007 Reviewed 02.10.2008