

Stanisław Strzelecki,
*Henryk Kapusta,
**Zdzisław Czaplicki,
**Kazimierz Ruskowski

High Speed Needle Punching Machine with Cylindrical Journal Bearings

Research-Development Centre of Textile Machinery
POLMATEX-CENARO,
ul. Wólczarska 76, 90-150 Łódź, Poland

*Łódź University of Technology,
ul. Stefanowskiego 15, 90-344 Łódź, Poland

**Institute of Natural Fibres,
ul. Poznańska 24, 83-456 Poznań, Poland

Abstract

The development process of non-woven technology and needle-punching machines assumes an increase in machine output, which can be achieved by an increase in machine speed. These machines are heavy, dynamically loaded and their operation depends on reliable journal bearings. The design of such bearings depends on the application of computer programs that allow to obtain the journal centre trajectory under a dynamic external load. This paper contains the results of evaluation of journal bearings of needle punching machines that can run at high speeds in dynamic load conditions. The programs applied and the results create a robust tool for the design of dynamically loaded journal bearings for both needle-punching machines and internal combustion engines.

Key words: non-woven, needle-punching machine, journal bearings, dynamic load.

also new hitherto unknown manufacturing machines, as well as influencing the development of new variations of traditional machines.

The development process of non-woven technology depends on progress in the production of passing needles, new design solutions for needle punching machines as well as on new driving systems for needle punching plates that allow for an increase in the punching speed. Passing needles, which are manufactured by highly specialised companies, have undergone significant changes in recent years in terms of needle materials and their design. The number of different types of punching needles is very wide, thus in the range of one manufacturer's production program, the user can obtain very specialised consultation. Differences lie in the hardness of the needle material, the number and shape of burrs on the operating part of the needle, the length of the needle's shank, special designs, and so on.

A classic needle-punching machine can be manufactured using different design solutions, e.g. as a machine with one or more needle-punching fields, with perforated flat or cylindrical plates, as the initial or final one, with the needle-punching plates placed one over the other (box needle-punching machine), or displaced fields as an anti-run needle-punching machine. Multiple punching fields in one machine is directly connected to its efficiency at the assumed parameters of the non-woven manufactured, such as the number of needle runs on the unit surface or the depth of punching. Another way to obtain an increase in the efficiency of a needle-punching machine is to increase the rotational speed of its main shaft.

Such a solution requires the application of special machine elements that transmit the drive from the electric motor to the machine's needle plate, which mainly concerns the eccentric or crankshafts that change the rotational motion to a to-and-fro motion as well as the pusher guides (tappets) of the mechanism of the needle plate. At present the most popular solution applied in the driving systems of needle-punching machines are gear boxes - splash or pressure lubricated. Such a solution decreases the overheating of the driving system, ensuring reliable lubrication and dampening the noise. Improving the manufacturing process by increasing the speed of machine elements requires additional equipment. For technical reasons it is necessary to place the machine on an additional, thick and heavy foundation and on special dampers. An acoustic cover for the full volume of the machine is also necessary. The speed of needle-punching machines in the first half of the XX century was about hundreds per minute, whereas at present these speeds are thousands per minute [1 - 4]. Together with the increase in punching speed, there has been a decrease in the magnitude of the stroke of needle punching plates. The stroke of needle punching plates is the largest for the initial punching, which decreases during basic punching to obtain the lowest values in specialised machines, e.g. for the closing of the non-woven structure punched. All these aspects certify the necessity for the development of very reliable and durable bearing systems for modern needle-punching machines, which are fitted with systems of continuous monitoring of both of the technological parameters of stitching and sensitive nodes of the mechanisms of needle punching machines.

■ Introduction

The development of textile technology can be described, among others, in terms of increasing production efficiency and improving the quality of the final product. An increase in both these factors depends on the development of manufacturing technology, new design solutions for production machines as well as their application in the design of machinery for materials and design elements of high performance. These rules concern non-woven technologies [1].

Non-woven materials as products in the flat textile range are relatively new structures. Stitch non-woven has found very wide application in the clothing industry, medicine and civil engineering. This field of textile production has generated not only new methods of manufacturing but

The tribological system of a needle-punching machine [5] consists of a gear box, journal bearings and lubricated guides. All these elements decide the performance of the machine. An increase in machine efficiency can be obtained by increasing the punching speed, which is decided by the correct design and technology of its dynamically loaded journal bearings [3 - 5]. Know-how on dynamically loaded bearing calculations [6 - 17] and access to robust and efficient computer programs [11, 12] allows to obtain bearings that fulfil the requirements of very efficient, high speed, heavy, dynamically loaded needle-punching machines.

Cylindrical journal bearings can transmit large loads at low or medium speeds of the shafts. Modifications in the design of these bearings [9, 11, 15, 16] allow to apply the supply of oil under higher pressures. Such bearings are hybrid ones combining a hydrodynamic action with a hydrostatic one, giving the possibility to control the bearing operation without mixed friction [10].

This paper concerns the analysis of the journal bearings of needle punching machines that can run at high speeds in dynamic load conditions. The effect of the type of bearing on the journal trajectory under a dynamic load was also investigated. A procedure that allows to calculate, analyse and design journal bearings for high performance needle-punching machines was applied. A modification of the main program of bearing calculation elaborated by us, allows to apply its results to other commercial programs devoted to obtain the deformation of bearings [12 - 14], which is very important in the case of the dynamically loaded bearing system.

■ Bearing loads

Investigation of punching in dynamic conditions was carried out for viscose fibres (Argon), polyacrylonitril (Anilana), polyoilphinowych (Polypropylen PP), phenol (Kynol) and their mixtures [1]. Example time runs of forces consist of the total value of the punching force at punching with a plate of 19 needles numbering 15×18×36×3.5 RB, which corresponds to No. 77/8 from the catalogue of the Famid Company (Poland) – these needles are mostly applied in the Polish industry. **Figure 1** gives the run of dynamic forces of punching raw material

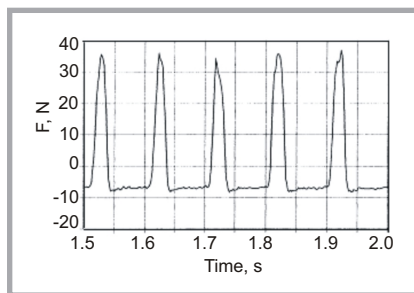

Figure 1. Time dependent run of the value of the punching force at a punching frequency of 10.07 Hz.

of $m_p = 480 \text{ g/m}^2$ made of the following elementary fibres: élan 3.3 dtex/87, élan HS and PP 6.7 dtex/90 mm of 50%, 20% and 30% proportions, respectively. The frequency of punching is given as l/min (number of strokes of the punching plate in a minute or the number of main shaft revolutions (r.p.m) of the crank mechanism). An example time dependent run of the value of the punching force at a punching frequency of 10.07 Hz is shown in **Figure 1**.

The physical model of a real system is based on the layout of the driving system of a punching bench [1]. This is a discrete model in which such elements as the gears, shafts, V-belts, and so on are

modelled as elastic-dissipative members. Properties of the kinematical chain elements, e.g. stiffness coefficient k , damping coefficient c are described on the respective elements in **Figure 2**.

In these conditions there is a lack of damping activity in the stitched fleece layer, and inertia forces reach extreme values for a given rotational speed of the shaft driving the stitching bench.

The main bearings are affected by the resultant inertia force of masses in rotational movement and masses in plane-back motion. The value of this force according to [1] is determined by the equation (1), where:

m_p - mass in plane-back motion, r - crank radius, ω - angular velocity of shaft, β - balance coefficient of masses in the plane-back motion, φ - angle of shaft rotation, $\lambda = r/l$, l - length of connecting rod.

Equation (1) gives the total inertia force of the first and second order. The direction of the non-balanced inertia force is determined from the equation (2):

$$\text{tg}\psi = \frac{-\beta \sin \varphi}{(1 - \beta) \cos \varphi + \lambda \cos 2\varphi} \quad (2)$$

$$W = m_p r \cdot \omega^2 \sqrt{\beta^2 + (1 - 2\beta) \cos^2 \varphi + 2(1 - \beta) \lambda \cos \varphi \cos 2\varphi + \lambda^2 \cos^2 2\varphi} \quad (1)$$

Equation 1.

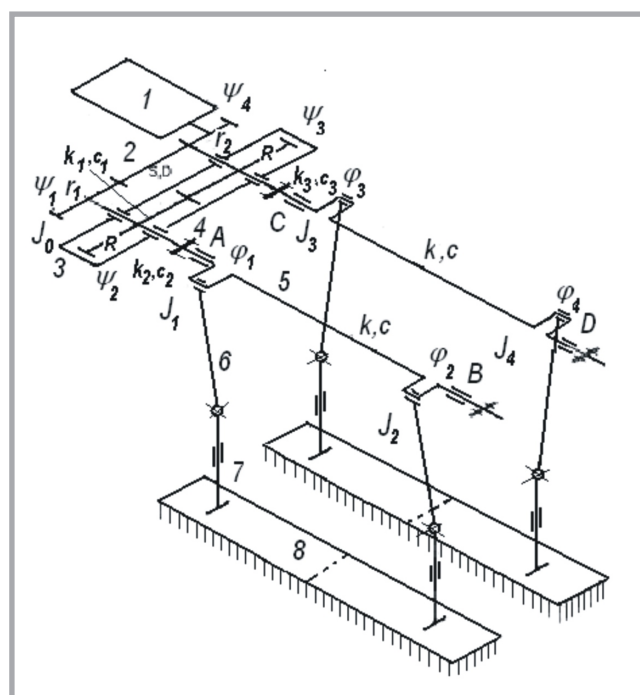

Figure 2. Lay-out of needle-punching machine: 1 - electric motor, 2 - belt drive, 3 - gear box, 5 - main shaft, 6 - crank mechanism, 7 - guide, 8 - needle bench, A, B, C, D - main journal bearings [1].

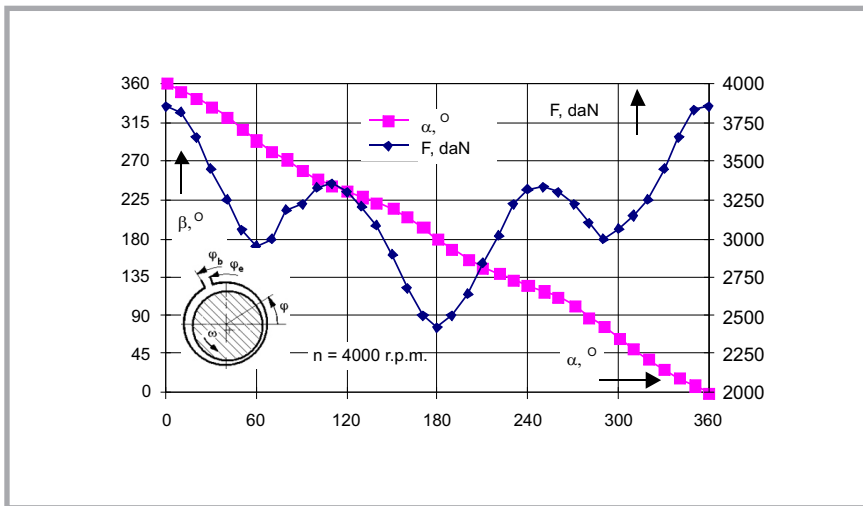

Figure 3. Dynamic load of bearing at the rotational speed of 4000 r.p.m.

$$\frac{\partial}{\partial \varphi} \left[\frac{H^3}{\eta} \frac{\partial \bar{p}}{\partial \varphi} \right] + \left(\frac{D}{L} \right)^2 \frac{\partial}{\partial \bar{z}} \left[\frac{H^3}{\eta} \frac{\partial \bar{p}}{\partial \bar{z}} \right] = 2 S_h \cdot \dot{\varepsilon} \cdot \cos(\varphi - \alpha) - 6 \cdot \varepsilon (1 - 2 S_h \dot{\alpha}) \sin(\varphi - \alpha) \quad (4)$$

Equation 4.

The vector of force W rotates with a variable angular velocity in a direction opposite to the velocity ω of the driving shaft.

Figure 3 introduces the run of the resultant force of inertia W calculated using the following data: $m_p = 24.2$ kg, $n_1 = 4000$ r.p.m., $\alpha = 1$, $\beta = 0.5$, $r = 0.015$ m, $l = 0.136$ m, $\lambda = 0.111$.

The resultant inertia force of 1st and 2nd order at $\alpha = 1$; $\beta = 0.5$; $\lambda = 0.111$;
 $W_{\max} = 0,611 m_p \cdot r \cdot \omega^2$

Journal centre trajectory

The main bearings of needle punching machines are loaded with large radial dynamic forces [1 - 5]. The reliable operation of a machine and its stable motion depend on the bearings.

Knowledge of journal centre trajectory [7, 11] allows the determination of the minimum oil film thickness, the maximum value of pressure and temperature distributions, i.e. the magnitudes required for the correct design of a journal bearing. The bearing clearance, the radius of operating surfaces of the bush and their displacement with regard to the circle inscribed in the bearing profile as well as the length of the bearing are magnitudes which can be established on the basis of the journal centre trajectory.

As a result of numerical analysis of a dynamically loaded cylindrical journal bearing [2 - 5], the pressure distribution and resultant force of the oil film, and the journal centre trajectory are obtained. The character and value of these loads determine equation (1) and Figure 1. The classic, cylindrical journal bearing with the geometry of lubrication gap given by equation (3) has been assumed for consideration:

$$H_c = 1 - \varepsilon \cdot \cos(\varphi - \alpha) \quad (3)$$

where: ε - relative eccentricity of the bearing, α - attitude angle, φ - peripheral co-ordinate.

The journal centre trajectory of the journal bearing considered was determined

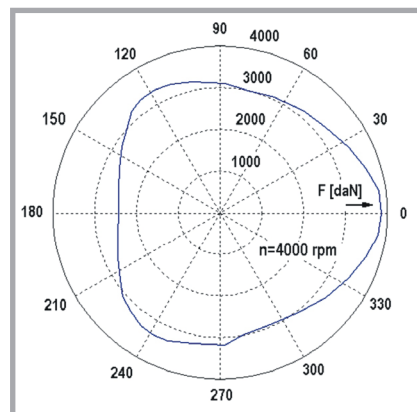

Figure 4. Diagram of a dynamic bearing load in a needle punching machine.

by numerical solution of the Reynolds, energy, viscosity and geometry of the oil film equations. The method [3, 11] applied for the solution of the Reynolds, energy, and viscosity equations and for determining the journal centre trajectory is characterised by the assumption necessary for describing the phenomena of lubrication and the dynamic of the tribological system: journal-lubricant-bearing bush, i.e.:

- the adding of pressures in the calculation of the components of the resultant hydrodynamic force,
- assumption of non-deformable journal and bush.

The method also assumes:

- conditions of heat exchange - isothermal or adiabatic model with the temperature determined from the heat balance,
- boundary conditions of the oil film - zones of negative pressure are neglected.

The Reynold's equation applied in the calculation of the journal centre trajectory has the form of equation (4) [11 - 17], where:

D - bearing diameter, L - bearing length, \bar{H} - dimensionless oil film thickness, \bar{p} - dimensionless oil film pressure, S_h - Strouhal number, \bar{z} - dimensionless axial co-ordinate, $\bar{\eta}$ - dimensionless viscosity of lubricant.

The pressure fields computed from equation (4) allows to obtain the resultant force \bar{W} of the bearing. Equating the oil film force \bar{W} to the load \bar{F} applied yields, at any instant, [5, 8],

$$\bar{F} = \bar{W} \left(\frac{L}{D}, \varepsilon, \alpha, \dot{\varepsilon}, \dot{\alpha} \right) \quad (5)$$

the calculation of the eccentricity, attitude angle, i.e. the journal centre trajectory in the function of the rotation angle of the driving shaft. The Runge-Kutta method has been applied for journal centre trajectory calculation [11]. Oil film temperature distributions were obtained from the coupled solution of pressure and energy equations [8, 12, 14].

Results of calculation

Calculation have been carried out for a set of cylindrical journal bearings as well as for 2-pocket cylindrical ones with a different arrangement of the pockets. Ap-

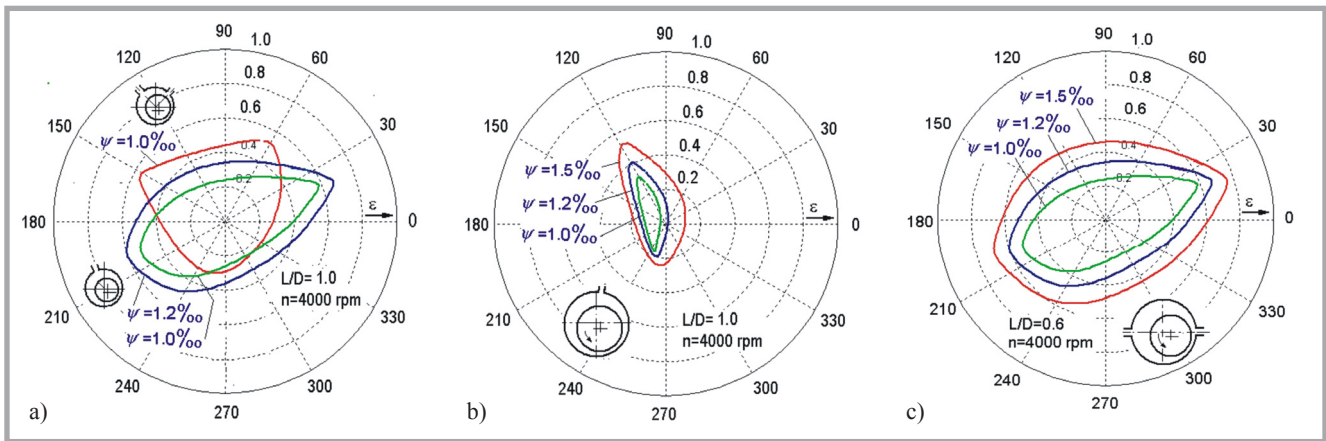

Figure 5. Journal trajectories in a dynamically loaded cylindrical and 2-pockets journal bearing of needle punching machine at different relative clearances of the bearing and different working conditions.

plication of pressurised lubrication and a supply of oil to two pockets allows to control the operation of the bearing. This paper concerns the results of calculation for the following cases: bearing diameter $D = 85$ mm; relative length of the bearing $L = 51$, $L = 65$, $L = 85$ mm, respectively, with aspect ratios $L/D = 0.6$, $L/D = 0.812$, and $L/D = 1.0$; journal speed $n = 4000$ r.p.m; relative clearance of the bearing $\psi = 1.0$ ‰, $\psi = 1.2$ ‰, and $\psi = 1.5$ ‰. The dynamic load applied for the calculations is shown in **Figure 4**.

Exemplary results of journal trajectory calculations are presented in **Figures 5**. The oil film pressure and temperature distributions are shown in **Figure 6.a & 7.b**, which result from calculations that, at an assumed bearing length to diameter ratio, variations in the relative clearance of the bearing have an effect on the journal trajectories. An increase in the relative clearance of the bearing causes an increase in the magnitude of the journal trajectory (**Figure 5**). At an assumed relative clearance of the bearing, an increase in the bearing length to diameter ratio decreases the extent of the journal trajectory and increases the minimum oil film thickness (e.g. **Figures 5.b & 5.c**)

Journal trajectories in a dynamically loaded 2-pocket cylindrical journal bearing of a needle punching machine at different relative clearances of the bearing are shown in **Figure 5.c**. There is a difference in the shape of trajectory compared with that of the cylindrical journal bearing (e.g. **Figures 5.b & 5.c**).

Exemplary oil film pressure distributions for two points on the journal trajectory and for two types of bearings are shown in **Figures 6**. For both cases at relative ec-

centricities considered, there is a similar run of pressure curves (e.g. **Figure 6.a**). In the case of a 2-pockets bearing, there are two ranges of oil film pressure (**Figure 6.b**), which is characteristic for such a type of bearings.

Exemplary distributions of the oil film temperature for two points on the journal trajectory are shown in **Figures 7**; at a small value of bearing relative eccentricity, $\epsilon = 0.18$, there is almost the same run of temperature distribution for both bearing

length to diameter ratios considered (**Figure 7.a**); the values of the maximum oil film temperature are almost equal. However, at a larger value of bearing relative eccentricity, $\epsilon = 0.38$ there is a difference in the run of oil film temperatures of the bearing calculated (**Figure 7.b**), with the maximum oil film temperatures reaching 102 °C and 87 °C for the bearing length to diameter ratios $L/D = 0.6$ and $L/D = 1.0$, respectively.

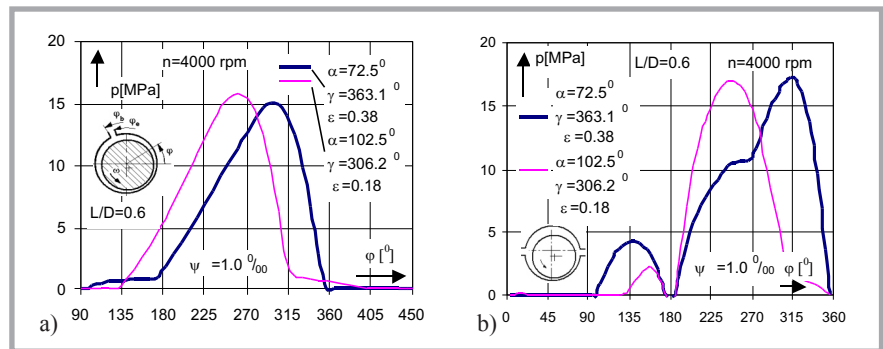

Figure 6. Oil film pressure distribution in a cylindrical journal bearing at different point of the journal trajectory and different working conditions.

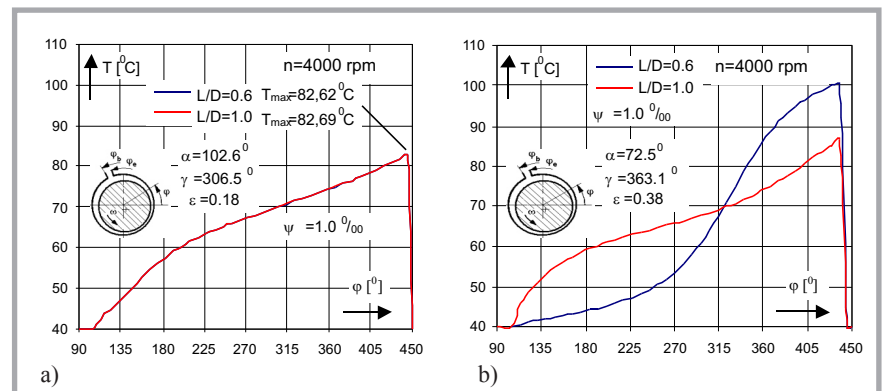

Figure 7. Oil film temperature distribution in a cylindrical journal bearing at an assumed point of journal trajectory and different working conditions.

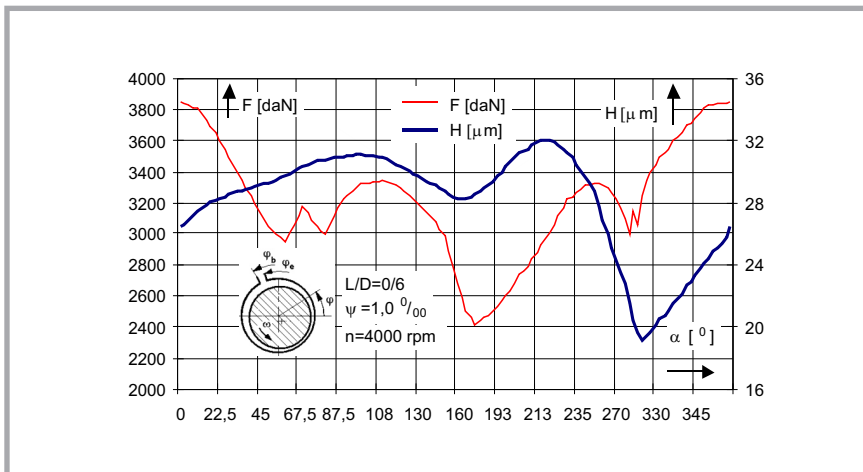

Figure 8. The run of load and oil film thickness versus the crank angle.

The oil film thickness and its minimum value are the most important bearing characteristics. The program of numerical calculations allows to obtain both parameters on the assumption of different bearing geometric and operational data. It is possible to analyse the effect of bearing parameters on both these performances.

The run of load and corresponding values of the oil film thickness for a cylindrical journal bearing can be observed in **Figure 8**. At a smaller value of the bearing's relative clearance, $\psi = 1.0 \text{ ‰}$, the value of the oil film thickness H ranges from about $19 \text{ } \mu\text{m}$ up to $32 \text{ } \mu\text{m}$ (**Figure 8**).

Conclusions

As result of the analysis and calculations of the journal centre trajectory for different types of journal bearings of a needle punching machine, the following conclusions can be drawn.

The journal centre trajectories for the types of cylindrical journal bearings considered depend on the profile of the bearing.

All trajectories obtained have a profile that is close to a deformed ellipse.

A trajectory close to a triangle with rounded tips was obtained for an asymmetrical cylindrical 2-pocket bearing.

Oil film pressures and temperature distributions on the journal peripheral are similar for different angles φ , resulting from the similarity of dynamic forces.

At an assumed dynamic load of the bearing, an increase in its relative clearance causes a decrease in the minimum oil film thickness.

The method of calculation and programs developed give a robust and very efficient tool that can be applied in the design process of dynamically loaded journal bearings of different profiles that operate, e.g. in needle punching machines.

References

1. Kapusta H. *Dynamic analysis of needle machine. Research report Technical University of Łódź 1998.* (in Polish)
2. Kapusta H., Strzelecki S., *Numerical Analysis of Needle Punching Machine Journal Bearings Operation. VI International Textile Conference IMTEX'2000. Łódź 2000. Textile Research. Scientific Bulletin Technical University of Lodz. No. 58. 341-347.*
3. Kapusta H., Strzelecki S., *Numerical analysis of slide bearings of a needle punching machine (in Polish). Proceedings of 6th International Science Conference IMTEX'2000. Informatyka Włókienniczej Inżynierii Mechanicznej i Informatyka we Włókienniczej Inżynierii Chemicznej, Łódź 2000. 1-6.*
4. Strzelecki S., Swiatek J., *Oil film pressure distribution in the dynamically loaded bearings of needle loom machine. SLAVYANTRIBO 6, 2004. Sankt Petersburg. 2004 Rybinsk 2004. Russia. Vol. 2. 257-265.*
5. Kapusta H., Strzelecki S., *Tribological System of Dynamically Loaded Journal Bearings of Needle Punching Machine. First Mediterranean Tribology Conference, Jerusalem, 8-9 November 2000.*
6. Jędrzejewski J. *Mechanics of crankshaft systems of combustion engines. 1986.* (in Polish)

7. Carl T., *Das zylindrische Gleitlager unter konstanter und sinusformiger Belastung. Eine experimentelle Untersuchung. Diss. TU Fridericana Karlsruhe. 1962.*
8. Strzelecki S., Someya T., *Maximum Oil Film Pressure and Temperature of Dynamically Loaded Journal Bearing. Proceedings of the 5th International Tribology Conf. in Australia. 6-9 December 1998. Brisbane, 219-224.*
9. Strzelecki S., *Maximum pressure and stresses in the dynamically loaded journal bearing with the peripheral oil groove. Journal of KONES 1997 Vol.2 No. 1 KONES'97. 23rd International Scientific Conference on Combustion Engines. Bielsko-Biała, Poland 1997, 433-438*
10. Strzelecki S., Wójcicki R., *Mixed lubrication in the dynamically loaded journal bearings. W. Journal of KONES. Internal Combustion Engines. Vol. 5, no 1. Warsaw, Scientific Publication of Permanent Committee of KONES, 1998; 294-299.*
11. Strzelecki S., *Journal centre trajectory of dynamically loaded Offset-Halves bearing Proceedings of the 3rd International Conference of Tribology, BALKANTRIB'99, June 1- 4 th 1999, Vol. II, Sinaia, Romania. 373-378.*
12. Strzelecki S., *Thermoelastohydrodynamic analysis of dynamically loaded journal bearings. 26th Int. Conference on Combustion Engines, KONES 2000. Nałęczów, 10-13 Sept. 2000, 497-502.*
13. Strzelecki S., *Problems of dynamically loaded engine journal bearings. Międzynarodowa Konferencja Motoryzacyjna '2000. KONMOT-AUTOPROGRES, Doskonalenie Konstrukcji, Technologii i Eksploatacji Pojazdów. 17-20.10.2000, Zakopane. Nr 20, 391-400.*
14. Strzelecki S., *Computation of Thermo-Elastic Deflections of Dynamically Loaded Cylindrical Journal Bearings. 27th Int. Conference on Combustion Engines, KONES 2001. September 9 - 12, 2001, Jastrzębia Góra. Conference Proceedings. 216 - 224.*
15. Strzelecki S., Ghoneam, S. M., *Dynamically Loaded Cylindrical Journal Bearing with Recess. KONES 2004. Zakopane. 2004. Journal of Kones Vol. 11, No.3-4. 234-241.*
16. Strzelecki S., Swiatek J., *Dynamically Loaded 2-Lobe Journal Bearing. Proc. of the 11th Nordic Symposium on Tribology NORDTRIB2004. Trømsø- Harstad-Hurtigruten. Norway. June 2004. 477-487.*
17. Strzelecki S., Swiatek J., *Dynamically Loaded 2-Lobe Journal Bearing. TRIBOLOGIA. Helsinki, Finland. September 2004. Finnish Journal of Tribology. Vol. 23/2004. 13-22.*

Received 26.02.2008 Reviewed 02.03.2009