

Investigation of Moisture Management and Air Permeability Properties of Fabrics with Linen and Linen-Polyester Blend Yarns

DOI: 10.5604/01.3001.0012.1311

¹Uludag University,
Department of Textile Engineering,
16059, Nilüfer, Bursa, Turkey

²Pamukkale University,
Buldan Vocational School,
Fashion&Design Programme,
20400, Buldan Denizli, Turkey
* E-mail: ggünaydin@pau.edu.tr

Abstract

This paper has focused on moisture management (MMT) and air permeability properties of fabrics produced from linen (100%) and linen-polyester yarns (80% polyester and 20% linen) at different weft densities. In the experimental study, eighteen different types of fabrics composed of six different weft yarns with three levels of weft density (weft density of 8, 10 & 12 pick/cm for 100% linen fabrics and 14, 16, 18 pick/cm for polyester-linen fabrics) were selected in order to determine the influence of weft density and yarn structural parameters (number of yarn folds) on moisture management as well as air permeability properties. The following weft yarns were selected: 104/1 tex, 104/2 tex & 104/3 tex for 100% linen and 41/1 tex, 41/2 tex & 41/3 tex for 80% Polyester – 20% linen fabrics, whereas the warp yarn was constant – 50/1 tex 100% linen for all fabric types. Satin type fabrics were subjected to moisture management tests and air permeability tests as well. According to test results, it was determined that some of the moisture management (wetting time, absorption rate (%/s) and one-way accumulative transport index of the fabrics' top surfaces and bottom surfaces) and air permeability properties were significantly affected by the number of yarn folds and the weft density at a 0.05 significance level.

Key words: comfort properties, moisture management properties, linen fabric, polyester-linen fabric, air permeability.

Introduction

The term comfort is defined as “the absence of displeasure or discomfort” or “a neutral state compared to the more active state of pleasure”. Three main considerations may be mentioned for comfort: psychological, sensorial and thermo-physiological. Thermo-physiological comfort requires thermoregulation and moisture management [1]. Moisture transportation through fabric is one of the key factors for fabric comfort. For wearer comfort, moisture management has the function of transporting sweat away from the skin and evaporating it to the atmosphere and also that of the weight control of cloth by preventing moisture increase on the fabric [2-4]. Moisture transport properties of textiles are obtained from perspiration in liquid and vapour form, which influences the dynamic comfort in practical use.

The interaction of liquids with textile materials includes some fundamental physical phenomena such as fibre surface wetting, liquid transfer into the assembly of fibres, adsorption on the fibre surface or diffusion of the liquid into the interior of the fibres. Wetting is described as the displacement of a solid-air interface with a solid-liquid one. Spontaneous wetting is the migration of a liquid, while forced wetting involves external mechanical forces for the increment of the solid-liquid interface beyond static equilibrium [5-6]. In the case of textile material, as

soon as water wets the fibre, it enters into the fibre's capillary channel and is dragged along by the action of capillary pressure, and the process which is called “wicking” takes place [3-4].

The special design of a fabric with a high moisture transport capacity may involve the selection of different fibre, yarn and fabric manufacturing systems. Natural fibres such as cotton and linen are hydrophilic, which means that their surface has bonding sites for water molecules. Therefore water tends to be retained in hydrophilic fibres which have poor moisture transportation and release. On the other hand, synthetic fibres such as polyester are hydrophobic, which means that their surface has few bonding sites for molecules. Hence they tend to remain dry, with good moisture transportation and release. Moisture absorption and release properties do not coexist in common fibres. These can be provided only by some special processes, such as microencapsulation. Air permeability is another indicator of fabric comfort as it plays a role in transporting moisture vapour from the skin to the outside atmosphere. An air permeable fabric provides the transition of liquid and vapour since this parameter affects the rate at which moisture is retained or lost by the fabric [7-9].

There are previous studies supporting the idea that some factors such as the raw material type, yarn structure and some fab-

ric properties directly influence moisture management properties as well as the air permeability of fabrics [10-11]. Selli and Turhan [12] made an investigation of the effects of knitting type, yarn count and commercially knitted fabric weight on comfort parameters in terms of air permeability and moisture management. Their results revealed that the air permeability of commercial knitted fabrics decreased as the mass of fabrics increased. Rib fabrics had higher air permeability values than single jersey fabrics. They also added that the wetting time (s) and absorption rate (%) increased as the mass of single jersey fabrics increased. In Özdil et al.'s study [13], cotton yarns produced at different yarn counts (30 tex, 20 tex, 15 tex) and different twist values were knitted as a single jersey structure. The dynamic liquid transport properties of textiles such as the wetting time (s), maximum absorption rate (%/s) and spreading speed (mm/s) were significantly influenced by the yarn count and yarn twist coefficient. The influence of knitting parameters such as the knitting gauge and stitch length on moisture management and air permeability were evaluated in Nazir et al. study [14]. Samples were produced at two different knitting gauges, each with three different stitch lengths. It was emphasised in the study that loosely knitted fabric samples with a higher amount of entrapped air revealed good air permeability but poor moisture management properties. The transmission of liquid

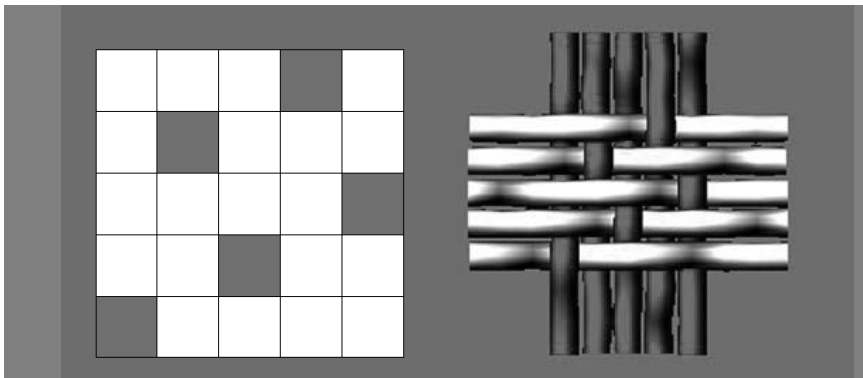

Figure 1. Photographs of 5/1 weft satin Z [3].

moisture for towels was studied in terms of fibre volume and fabric thickness. It was found that as the thickness of fabric or fibre volume increased, more resistance was offered to moisture transmission [15]. Çeven and Gürarda [16] investigated the air permeability, breaking strength and abrasion resistance of curtain fabrics woven with polyester yarns having different structures. They concluded that yarn structure such as the twist, linear density, friction, crimp, number of plies (e.g. singles, two-ply etc.), smoothness and presence of wrapper or binding fibres affected curtain fabric performance. Apart from the raw material and fabric structure influence, the effect of washing types (such as ultrasonic and conventional) and washing cycles was also found to be a significant factor for moisture management properties [17-19].

From the literature investigated, it can be seen that the moisture management and air permeability properties of fabrics

have become a serious research area in recent years. However, it should be emphasised that most of the studies have focused on evaluating the comfort properties of knitted fabrics. It has been found that there are not many studies related to the influence of yarn parameters (such as yarn type, number of yarn ply and yarn twist) or fabric structure (weft density, weaving type etc.) on the moisture management and air permeability properties of linen containing woven fabrics. Our present study investigated the comfort related properties of 100% linen and 80% polyester-20% linen fabrics on the basis of weft yarn type and weft densities with the help of dynamic liquid moisture management and air permeability tests.

Material method

Material

In order to evaluate the influence of yarn structure and weft density on the moisture management of fabric and its air perme-

ability, 18 different types of drapery fabrics were produced using the same type of warp yarn – 50/1 tex (Z) ring spun linen yarn. but with different weft yarns, which were one, two and three folded spun yarns. 100% linen ring spun weft yarns (104/1 tex, 104/2 tex, 104/3 tex) were used at a density of 8,10 and 12 pick/cm, whereas 80% polyester – 20% linen ring spun weft yarns (41/1, 41/2, 41/3 tex) were used at a density of 14-16-18 pick/cm. 5/1 weft satin Z [3] drapery fabrics (Figure 1) were woven on a Dornier model weaving machine (Lindauer DORNIER GmbH, Lindau Germany). After the weaving process, PVA, SAFİLİN 2REF was applied to the warp yarns for sizing. The fabrics were pre-treated with 4 g/l soap during desizing. All fabrics were subjected to wrinkle resistance processes using 30 g/l resin with MgCl and to the tamper process, respectively. Additionally 40 g/l softener was used as the finishing process. The drapery fabrics were tested with a Moisture Management Tester (MMT, SDL ATLAS LTD, Hong Kong) based on the standard AATCC 195-2009 [20] and tested with an SDL Atlas Digital Air Permeability Tester (SDL ATLAS LTD, Hong Kong) according to the EN ISO 9237 standard [21]. All measurements were carried out in controlled laboratory conditions of 20 ± 2 °C, % 65 ± 4 relative humidity. The experimental design is summarised in Table 1.

Method

Moisture management

As mentioned above in the literature part, moisture has an important impact on thermal and sensory comfort. The volume of liquid required to saturate a fabric varies according to the fabric moisture characteristics, fabric thickness and rate of liquid loss due to evaporation. In this study, the moisture management of fabrics was measured with a Moisture Management Tester (MMT, SDL Atlas) based on the standard AATCC 195-2009 [20]. In order to remove possible residue on the fabric, it was preferred to wash them for five minutes with distilled water using an ultrasonic cleaner before the test. Figure 2 reveals the working principle of the device. To conduct the test, the fabric sample was placed horizontally in the MMT instrument between the upper and lower sensors, which are made of concentric rings of pins. A solution representing perspiration was dropped on the centre of the upper face (skin side) of the test sample. The fabric's top side was that on which the test water was dropped during testing, which is supposed to be in contact with

Table 1. Experimental design.

Fabric code	Fabric composition	Weft yarn	Pick, cm	Weight, g/m ²
104/1 (8)	100% linen	104/1 tex, linen Ring Spun	8	199.8
104/1 (10)			10	222.5
104/1 (12)			12	244.6
104/2 (8)	100% linen	104/2 tex, linen Ring Spun (130 S)	8	290.6
104/2 (10)			10	336.1
104/2 (12)			12	381.5
104/3 (8)	100% linen	104/3 Tex, linen Ring Spun (130 S)	8	462.5
104/3 (10)			10	530.6
104/3 (12)			12	598.75
41/1 (14)	80%Polyester 20% linen	41/1 tex, Polyester-linen Ring Spun	14	253.58
41/1 (16)			16	262.60
41/1 (18)			18	271.75
41/2 (14)	80%Polyester 20% linen	41/2 tex, Polyester-linen Ring Spun (550 S)	14	317.16
41/2 (16)			16	335.33
41/2 (18)			18	353.50
41/3 (14)	80%Polyester 20% linen	41/3 tex , Polyester-Linen Ring Spun (550 S)	14	380.75
41/3 (16)			16	408.80
41/3 (18)			20	462.50

human body skin while worn in a garment made by the fabric. As the solution moved through and across the sample, the changes in electrical resistance were measured and recorded [22]. The results were expressed in terms of the wetting time (s), absorption rate (%/s), spreading speed (mm/min) and maximum wetted radius for top and bottom surfaces (mm) as well as in terms of the accumulative one-way transport index (AOTI) and overall (liquid) moisture management capability (OMMC). Definitions of these terms are given below [22-25];

- *Wetting Time (s)* is defined as the time in seconds when the top and bottom surfaces of the specimen begin to be wetted after the test is started.
- *Absorption rate for top and bottom surfaces (%/s)* is defined as the average speed of liquid moisture absorption for the top and bottom surfaces of the specimen during the liquid pumping time.
- *Maximum wetted radius (MWR_{top}, MWR_{bottom})* is defined as the maximum wetted ring radius at the top and bottom surfaces, where the slopes of water content become greater than tan 15° for the top and bottom surfaces, respectively.
- *Spreading Speed* is defined as the cumulative wetting spreading speed (mm/s) between the center of the specimen where the liquid is dropped and the maximum wetted radius. If it is assumed that the ring is wetted in a time period of t_i , ($i = 1, 2, 3, 4, 5, 6$), the liquid spreading speed from the ring of $i-1$ to ring i is calculated as shown in **Equation (1)**. Here “R” is defined as the diameter of the ring. The cumulative spreading speed (SS) is calculated as shown in **Equation (2)**, where N is the maximum number of wet rings;

$$S_i = \frac{\Delta R_i}{t_i} = \frac{R}{t_i - t_{i-1}} \quad (1)$$

$$SS = \sum_{i=1}^N S_i = \sum_{i=1}^N \frac{R}{t_i - t_{i-1}} \quad (2)$$

- *Accumulative One-way Transport Index (AOTI)* is the difference in the accumulative moisture content between the two surfaces of the fabric. One way transportation capability may also be described as one-way liquid moisture transfer from the fabric’s inner surface to the outer surface [23].

$$AOTI = (\text{Area}(U_{\text{bottom}}) - \text{Area}(U_{\text{top}})) / \text{Total testing time} \quad (3)$$

- *Overall Moisture Management Capability (OMMC)* is an index revealing

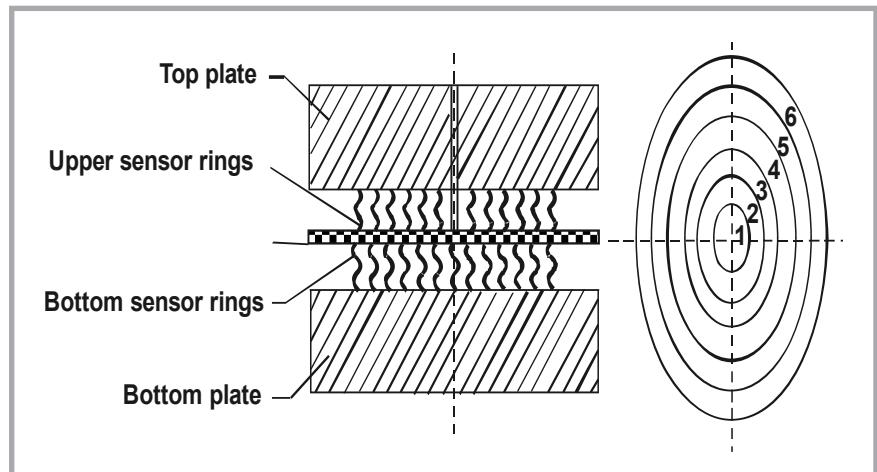

Figure 2. Working principle of MMT Test Equipment [22].

fabric ability to manage liquid moisture transport. This index consists of three aspects of performance: the moisture absorption rate of the bottom side (BAR), the accumulative one-way transport index (AOTI), and spreading/drying rate of the bottom side (SS_b), which is represented by the maximum spreading speed. The larger the OMMC, the higher the overall moisture management ability of the fabric [3]. The overall moisture management capability (OMMC) is defined as:

$$OMMC = 0.25BAR + 0.5AOTI + 0.25SS_b \quad (4)$$

The moisture management of the fabrics was evaluated in terms of the wetting time, absorption rate, maximum wetted

radius, spreading speed, accumulative one-way transport Index and overall moisture management capacity as well. **Table 2** displays grading of MMT indices. The indices are graded and converted from value to grade based on a five grade scale (1–5). The five grades of indices represent: 1 – Poor, 2 – Fair, 3 – Good, 4 – Very good, 5 – Excellent.

Air permeability

The air permeability of the fabrics was measured based on the EN ISO 9237 standard [21] using an SDL Atlas Digital Air Permeability Tester Model M021A at 20±2 °C and 65±4% humidity. Measurements were performed by application of 100 Pa air pressure per 20 cm² fabric surface. The averages of measurements

Table 2. Grading of MMT indices [25].

Index		Grade				
		1	2	3	4	5
Wetting time, s	Top	≥120	20-119	5-19	3-5	<3
		No wetting	Slow	Medium	Fast	Very Fast
	Bottom	≥120	20-119	5-19	3-5	<3
		No wetting	Slow	Medium	Fast	Very Fast
Absorption rate, %	Top	0-10	10-30	30-50	50-100	>100
		Very slow	Slow	Medium	Fast	Very Fast
	Bottom	0-10	10-30	30-50	50-100	>100
		Very slow	Slow	Medium	Fast	Very Fast
Max. Wetted Radius, mm	Top	0-7	7-12	12-17	17-22	>22
		No wetting	Small	Medium	Large	Very large
Max. Wetted Radius, mm	Bottom	0-7	7-12	12-17	17-22	>22
		No wetting	Small	Medium	Large	Very large
Spreading speed, mm/s	Top	0-1	1-2	2-3	3-4	>4
		Very slow	Slow	Medium	Fast	Very Fast
	Bottom	0-1	1-2	2-3	3-4	>4
		Very slow	Slow	Medium	Fast	Very Fast
AOTI	Top	<-50	-50 to 100	100-200	200-400	>400
		Poor	Fair	Good	Very good	Excellent
OMMC	Bottom	0-0.2	0.2-0.4	0.4-0.6	0.6-0.8	>0.8
		Poor	Fair	Good	Very good	Excellent

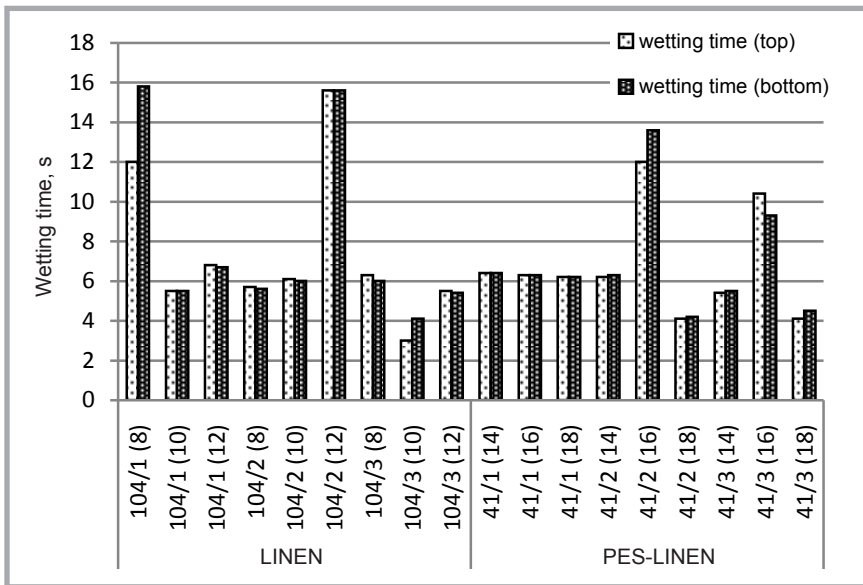

Figure 3. Wetting time of the fabrics.

from 10 different areas of the fabrics were calculated. The pre-selected unit of measure was dm^3/s for the debit of air flow. The air permeability (mm/s) was determined as follows [16]:

$$R = \left(\frac{\bar{q}_v}{A}\right) \times 167 \quad (5)$$

Where \bar{q}_v : the arithmetical average of the debit of air flow, dm^3/min ; A: Test area, cm^2 ; and 167: the coefficient of conversation from dm^3/min to cm^3/s and then from cm/s to mm/s .

Results were expressed in “ mm/s ”. Air permeability is related to the porosity of fabrics, which is influenced by the fibre

type, yarn structure, weft density, weaving type etc. Looser fabric structures lead to higher air permeability due to the lower cover factor.

Results and discussion

Moisture management properties

The moisture management performances of the fabrics were evaluated in terms of the wetting time (s), absorption rate ($\%/s$), maximum wetted radius (mm), the spreading speed (mm/s) for top (SS_{top}) and bottom surfaces (SS_{bottom}), the accumulative one-way transport index (AOTI) and overall moisture management capac-

ity (OMMC). In order to evaluate the influence of the number of yarn folds and weft density on the moisture management of the fabrics, completely randomised two-factor analysis of variance (ANOVA) was conducted. ANOVA results for all dynamic liquid moisture management properties are given in Table 3.

It should be stated that the yarn fold, weft density and their interaction had a significant effect (5% significance level) only on the wetting time, absorption rate ($\%/s$) and one-way accumulative transport index of the fabrics’ top and bottom surfaces, whereas the yarn fold, weft density and their interaction did not have any significant effect on the maximum wetting radius (mm), spreading speed (mm/s) and overall moisture management capacity (OMMC).

Wetting time (s)

The wetting time of the top and bottom surfaces after the liquid had been applied is revealed in Figure 3. It was observed that the wetting times (s) of the fabrics’ top and bottom surfaces fluctuate between 4 and 16 seconds. Regarding the fabrics with linen weft yarn, the maximum top wetting time (WTT) was obtained for the fabrics with 104/2 tex linen yarn at a weft density of 12-15.6 seconds, whereas the maximum wetting time of the bottom (WTB) surface was obtained for fabrics with 104/1 tex linen yarn at a weft density of 8-15.8 seconds. The minimum wetting times for the top and bottom surfaces belong to fabrics with 104/3 tex linen weft yarn at a weft density of 10 – 5.1 and 4.1 seconds, respectively.

Regarding the fabrics with linen-polyester blend weft yarn, those with 41/2 tex weft yarn at a weft density of 16 revealed the highest wetting time for top and bottom surfaces (12 s and 13.6 s), whereas the fabrics with 41/2 tex yarn at a weft density of 18 had the lowest wetting time for top and bottom surfaces (4.1 s and 4.2 s). According to ANOVA (two-way) test results, the properties displayed in Table 3 i.e. the number of yarn folds, the weft density and their interaction, had a significant effect on both the top ($p < 0.05$) and bottom ($p < 0.05$) surfaces of the wetting times at a 95% confidence interval. SNK results for the top wetting time (WTT) and bottom wetting time (WTB) surfaces are also displayed in Table 4.

According to Table 4, regarding the fabrics with 100% linen weft yarn, SNK test

Table 3. ANOVA results for dynamic liquid moisture management properties. Note: *statistically important according to $\alpha = 0.05$.

Anova test results for fabrics’ MMT results			Fabrics with 100% linen weft yarn			Fabrics with polyester-linen blend weft yarn		
	Source		df	F	Sig (p)	df	F	Sig (p)
Wetting Time (top)	main effect	Yarn fold	2	39.747	0,00	2	4,919	0.01*
		Weft Density	2	44.144	0,00	2	90.529	0.00*
	interaction	F*D	4	67.259	0,00	4	23,013	0.00*
Wetting Time (bottom)	main effect	Yarn fold	2	73.201	0,00	2	8,373	0.00*
		Weft Density	2	71.198	0,00	2	147,535	0.00*
	interaction	F*D	4	109.537	0,00	4	47,680	0.00*
Absorption Rate (top)	main effect	Yarn fold	2	7.927	0,03	2	44,886	0.00*
		Weft Density	2	196.977	0,00	2	109,041	0.00*
	interaction	F*D	4	76.203	0,00	4	131,292	0.00*
Absorption Rate (bottom)	main effect	Yarn fold	2	219.110	0,00	2	617,076	0.00*
		Weft Density	2	287.207	0,00	2	593,711	0.00*
	interaction	F*D	4	96.377	0,00	4	184,670	0.00*
One-way accumulative transport index	main effect	Yarn fold	2	88.857	0,00	2	3781,251	0.00*
		Weft Density	2	1501.726	0,00	2	2614,708	0.00*
	interaction	F*D	4	662.074	0,00	4	605,666	0.00*

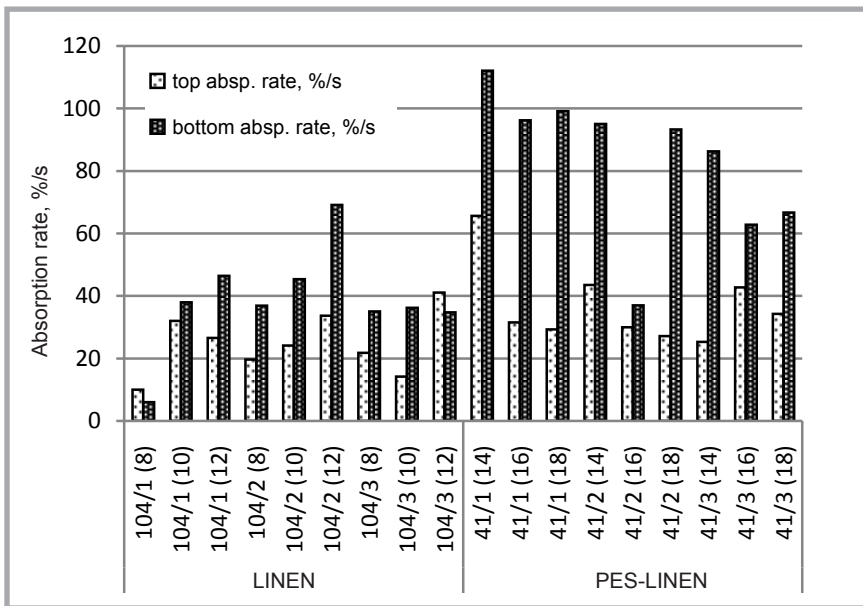

Figure 4. Maximum absorption rates (%/s) of the fabric.

results revealed that the fabrics produced with different yarn folds possessed a statistically different wetting time (s) for the top and bottom surfaces. The highest wetting time for the top surfaces was obtained for fabrics with two folded linen weft yarns, whereas the minimum values were found in fabrics with three folded linen weft yarns. There was not a trend for the ranking of the fabrics' wetting time for top surfaces with respect to the number of yarn folds. However, there was a decrement in the wetting time for bottom surfaces as the yarn fold increased. On the other hand, SNK results also revealed that fabrics of various weft density possessed different wetting times (s) for the top and bottom surfaces. The maximum wetting time for both the top and bottom surfaces was observed in fabrics with a weft density of 12-9.30 s and 9.23 s, respectively, whereas minimum values were observed in fabrics with a weft density of 10-5.56 s for top and 5.20 s for bottom surfaces. When it comes to the top wetting time (s) and bottom wetting time (s) of the fabrics with linen-polyester blend weft yarn, SNK results revealed that fabrics with one fold and three folded yarns were statistically in the same subset at a significance level of 0.05. The fabrics with two-fold polyester-linen blend yarn had the maximum wetting time for both surfaces. SNK test results also indicated that polyester-linen blend fabrics produced with different weft densities possessed statistically different wetting times (s) for the top and bottom surfaces. The maximum wetting times for the top and bottom surfaces were found

in fabrics with a weft density of 16, and minimum wetting times belonged to fabrics with a weft density of 18.

Absorption rate (%/s)

The absorption rate (%/s) values indicate the average moisture absorption ability of the top and bottom surfaces of the fabric in the pulp time (20 s). According to Figure 4, the maximum absorption rates (%/s) of the top and bottom surfaces were found in fabrics with 104/3 tex 100% linen weft yarns at a weft density of 12 and in fabrics with 104/2 tex 100% linen weft yarns at a weft density of 12, respectively. Minimum absorption rates (%/s) of the top and bottom surfaces were found

Table 4. SNK Results for the wetting time (sec). Note: The different letters (a, b, c) next to the counts indicate that they are significantly different from each other at a significance level of 5%.

Fabrics with linen weft yarn			
Parameter		WTT	WTB
Yarn fold (F)	1	8.10b	9.33b
	2	9.13c	9.06b
	3	5.63a	5.16a
Weft density (D)	8	8.00b	9.13b
	10	5.56a	5.20a
	12	9.30c	9.23b
Fabrics with polyester-linen blend weft yarn			
Parameter		WTT	WTB
Yarn fold (F)	1	6.30a	6.30a
	2	7.43b	8.03b
	3	6.63a	6.43a
Weft density (D)	14	6.00b	6.06b
	16	9.56c	9.73c
	18	4.80a	4.96a

in fabrics with 104/1 tex weft yarns at a weft density of 8. Fabrics with polyester-linen blend weft yarn revealed higher bottom-absorption rates (%/s) compared to the bottom-absorption rates (%/s) of fabrics with 100% linen weft yarns.

Considering the polyester-linen fabrics, the maximum absorption rates (%/s) of the top and bottom surfaces were observed in fabrics with 41/1 tex weft yarn at a weft density of 14 pick/cm at 65.6 and 112.1 %/s, respectively. The lowest top absorption rates (%/s) belonged to fabrics made of 41 tex/3 polyester-linen weft yarn at a weft density 14 of pick/cm, whereas the lowest bottom absorption

Table 5. SNK Results of absorption rates (%/s). Note: The different letters (a, b, c) next to the counts indicate that they are significantly different from each other at a significance level of 5%.

Fabrics with linen weft yarn			
Parameter		Absorption rates for top surfaces (%/s)	Absorption rates for bottom surfaces (%/s)
Yarn fold (F)	1	22.83a	30.10a
	2	25.80b	50.43c
	3	25.70b	35.30b
Weft density (D)	8	17.13a	25.96a
	10	23.43b	39.80b
	12	33.76c	50.06c
Fabrics with polyester-linen blend weft yarn			
Parameter		Absorption rates (%/s) for top surfaces	Absorption rates (%/s) for bottom surfaces
Yarn fold (F)	1	42.02b	102.46c
	2	33.53a	75.10b
	3	34.11a	71.93a
Weft density (D)	14	44.68c	97.80c
	16	34.73b	65.33a
	18	30.24a	86.36b

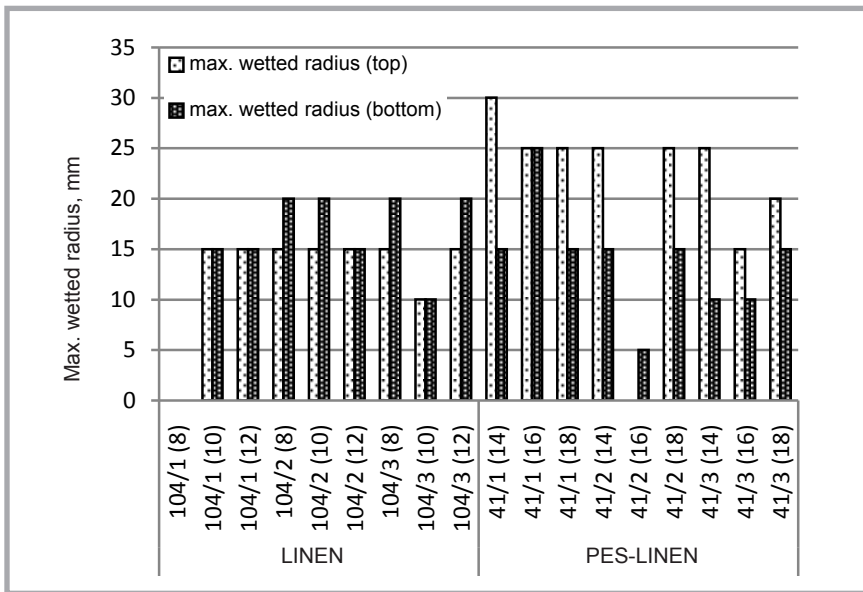

Figure 5. Maximum Wetted Radius(mm) for top and bottom surfaces.

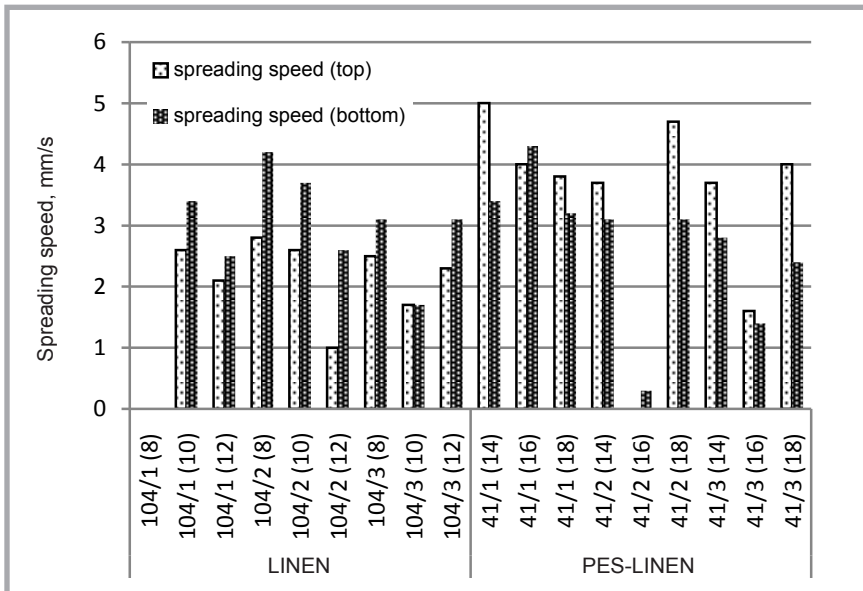

Figure 6. Spreading speed (mm/s) values of the fabrics for top and bottom surfaces.

rates (%/s) were obtained for fabrics with 41/2 tex weft yarn at a weft density of 16. As observed in **Figure 4**, especially among fabrics with polyester-linen blend weft yarns, the bottom absorption rates (%/s) of the fabrics were generally higher than those of the top surfaces, which indicates that there is liquid diffusion from the next-to-wet surface to the opposite side. Hence the liquid is accumulated on the bottom surface of the fabric.

SNK test results (**Table 5**) revealed that regarding fabrics with 100% linen weft yarn, those produced with different yarn folds possessed statistically different absorption rates (%/s) for the top and bot-

tom surfaces. Among the fabrics with 100% linen weft yarn, those with two-fold weft yarns revealed the highest absorption rates (%/s) for top and bottom surfaces, whereas fabrics with one-fold weft yarns had the minimum absorption rates (%/s). There was also a significant effect of the weft density on the absorption rates (%/s) of linen fabrics for the top and bottom surfaces at a 0.05 significance level. As is observed from **Table 5**, there was an increasing trend for the absorption rates (%/s) of the top and bottom surfaces of the linen fabrics as the weft density increased from 8 to 12 pick/cm. Additionally SNK results of the fabrics with polyester-linen blend yarns showed

that there was a significant difference between the absorption rates (%/s) of the top and bottom surfaces of the fabrics at a 0.05 significance level. As the number of yarn folds increased, the absorption rates (%/s) of the top surfaces exhibited some fluctuation, whereas there was an overall downward trend for those (%/s) of the bottom surfaces of polyester-linen fabrics. The weft density increment led a downward trend for the absorption rates (%/s) of top surfaces; however, this was not clear for the bottom surfaces of polyester-linen fabrics.

Maximum wetted radius

According to **Figure 5**, regarding fabrics with 100% linen weft yarn, the minimum value of the max. wetted radius (mm) of the top and bottom surfaces of the 104 tex/1 fabrics at a (pick/cm) weft density of 8 is zero, whereas the rest radius (mm) values of the top and bottom surfaces fluctuated between 10 and 20 mm among the fabrics with 100% linen weft yarns. There was a general trend for fabrics with polyester-linen weft yarn in their providing higher max. wetted radius values for the top surface compared to their bottom surface. However, this trend was not valid for fabrics with 41 tex/1 weft yarn at a weft density of 16 pick/cm, nor for fabrics with 41 tex/2 weft yarn at a weft density of 16 pick/cm, which revealed the lowest maximum wetted radius values (mm) for top and bottom surfaces. Additionally, according to Anova tests, the number of yarn folds and the weft density did not have any significant effect on both the top ($p > 0.05$) and bottom ($p > 0.05$) maximum wetting radius values of any 100% linen or polyester-linen fabrics at a 95% confidence interval (**Table 3**).

Spreading speed (mm/s)

Figure 6 shows the spreading speed (mm/s) values of the fabrics. Regarding the fabrics with 100% linen weft yarn, the lowest spreading speed (mm/s) belonged to fabrics with 104/1 tex yarn at a weft density of 8 pick/cm at “zero (0)” for the top and bottom surfaces, which means the fabric has very low spreading speed according to the MMT test grading scales (**Table 2**). Additionally the maximum spreading speed (mm/s) of the top and bottom surfaces was obtained for fabrics of 104/2 tex yarn at a weft density of 8 pick/cm – 2.8 mm/s and 4.2 mm/s respectively.

Regarding the fabrics with polyester-linen weft yarn, the lowest spreading speed

(mm/s) belonged to fabrics with 41/2 tex yarn at a weft density of 16 pick/cm – “0” mm/s for the top surface and “0.3” mm/s for the bottom surface, which means the fabric has a very low spreading speed according to the MMT test catalogue (Table 2). Additionally the maximum spreading speed (mm/s) value for the top surface was found to be “5 mm/s” in fabrics with 41/1 tex weft yarn at a weft density of 14 (pick/cm), whereas the maximum spreading speed (mm/s) value for the bottom surface was found to be “4.3” in fabrics with 41/1 tex yarn at a weft density of 16 pick/cm. Additionally with respect to Anova tests, the number of yarn folds and the weft density did not have any significant effect on both the top ($p > 0.05$) and bottom ($p > 0.05$) spreading speed properties of 100% linen or polyester-linen fabrics at a 95% confidence interval (Table 3).

Accumulative one-way transport index (AOTI)

Figure 7 reveals the Accumulative one-way transport index of the fabrics. This parameter describes how easily a fabric can transport moisture absorbed from its conducting surface to the other side by providing a moisture feel reduction, which is a sign of fabric comfort. High comfort fabrics are expected to have a high accumulative one-way transport index value. As is observed from Figure 7, the fabric groups with polyester-linen blend weft yarns had a much higher accumulative one-way transport index compared to those with 100% linen weft yarn. This can be attributed to the fact that polyester fibres can pass moisture from the inner to outer surface of the fabrics more easily than linen fibres. A research conducted by Namlıgöz et al. also supported our results, where the accumulative one-way transport of the cellulosic/synthetic blends revealed higher values compared to 100% cellulosic based fabrics. The researchers explained this by way of cellulose based fibres’ tendency to absorb moisture instead of transportation [23].

According to SNK test results (Table 6) for the Accumulative one-way transport index of fabrics with linen weft yarn, those produced with different numbers of yarn folds and weft densities possessed a statistically different accumulative one-way transfer index. There was not a clear trend for the accumulative transport index of 100% linen fabrics as the yarn fold or weft density increased. The maximum accumulative one-way transport

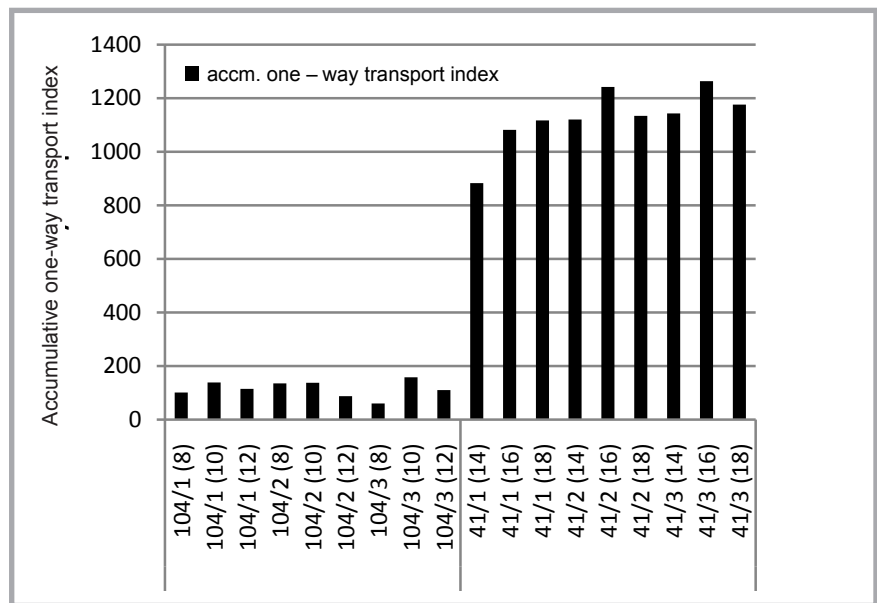

Figure 7. Accumulative one-way transport index.

index was obtained for the fabrics with two-folded 100% linen weft yarn of 104/1 tex – 120.36, whereas the minimum value was obtained for the fabrics with three-folded 100% linen weft yarn of 104/3 tex – 108.93. The maximum accumulative transport index of linen fabrics was obtained for the fabric groups at a weft density of 10 pick/cm, whereas the minimum value belonged to those at a weft density of 8 pick/cm – 98.66. Regarding fabrics with polyester-linen weft yarn, the fabrics produced with different yarn folds and weft densities possessed statistically different Accumulative transport indices (Table 6). There was an upward trend for the accumulative transport index of the fabrics as the yarn fold increased; however, this trend was not clear for the weft densities. The highest accumulative transfer index was obtained for polyester-linen fabrics at a weft density of 16 – 1195.76, whereas the minimum value was obtained in polyester-linen fabrics at a weft density of 18 – 1142.56.

Overall moisture management capacity results (OMMC)

As mentioned above in the material-method section, the overall moisture management capacity (OMMC) defines the ability of the fabric to manage liquid moisture transport with the performance aspects of the moisture absorption rate of the bottom side, the one-way liquid transport capacity (AOTI), and the spreading/drying rate of the bottom side (SS_b) presented by the maximum spreading speed. According to the test results, OMMC values calculated for linen fabrics had poorer moisture

Table 6. SNK Results of Accumulative one-way transport index of the fabrics. Note: The different letters (a, b, c) next to the counts indicate that they are significantly different from each other at a significance level of 5%.

Fabrics with linen weft yarn		
Parameter		Accumulative one-way transfer index
Yarn fold (F)	1	117.90b
	2	120.36c
	3	108.93a
Weft density (D)	8	98.66a
	10	144.10c
	12	104.43b
Fabrics with polyester-linen blend weft yarn		
Parameter		Accumulative one-way transfer index
Yarn fold (F)	1	1027.16a
	2	1165.53b
	3	1194.51c
Weft density (D)	14	1048.87a
	16	1195.76c
	18	1142.56b

management ability when compared with polyester-linen fabrics. The results fluctuated between “0” and “0.5” for linen fabrics, which indicated that the fabrics were of a poor, fair and good grade according to the MMC grading scale. On the other hand, the OMMC results were found to be between 0.5 and 0.9 for polyester-linen fabrics. According to the MMC grading scale, the polyester-linen fabrics were of a good, very good and excellent grade in terms of the Overall Moisture Management Capacity (Table 2). It is also observed that the general trend for Figure 8 was similar to that in Figure 7 (one-way accumulated transport index), which may

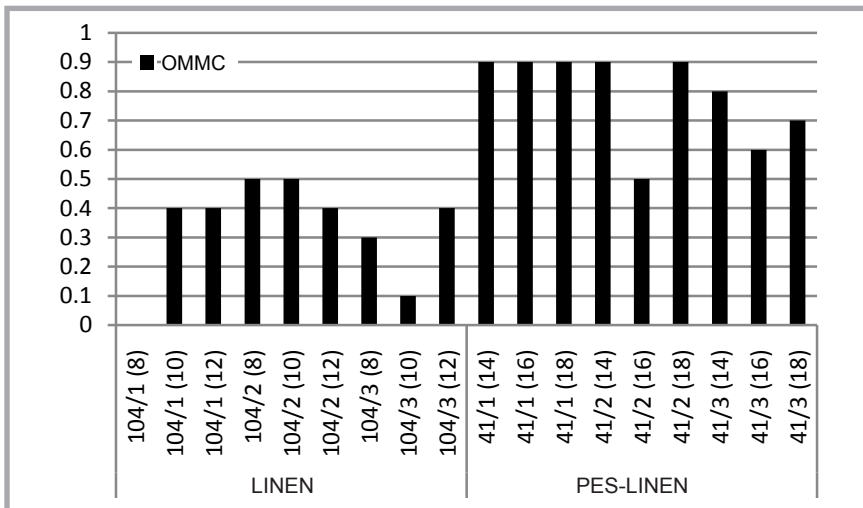

Figure 8. Overall Moisture Management Capacity Results of the fabrics.

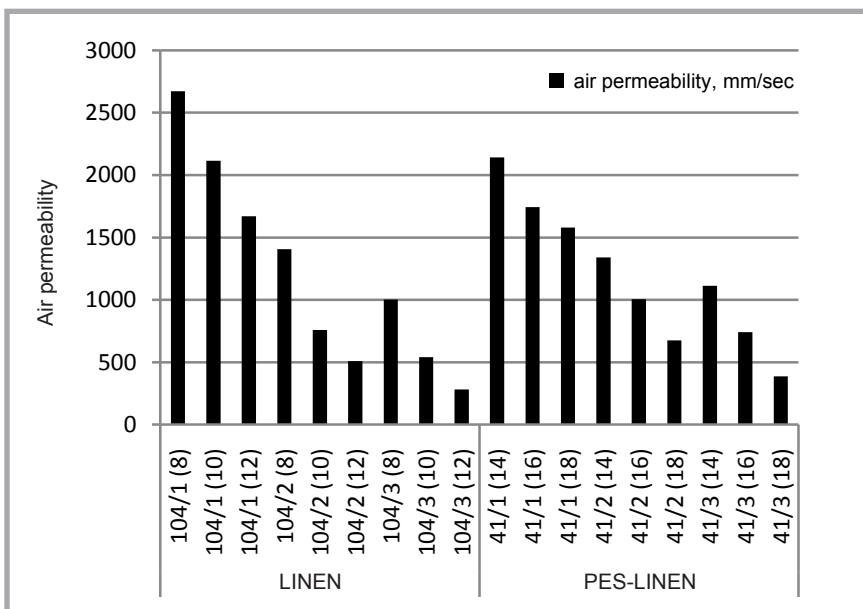

Figure 9. Air permeability test results of the fabrics.

indicate that these two terms: “OMMC” and “AOTI” are highly interrelated. It can be emphasised that when linen fibre is blended with polyester, there is an improvement in the accumulative one-way transport index and overall moisture management capacity results, which can be attributed to the capillary cavities of polyester fibre. There are some studies supporting our results, where fabrics of polyester blends revealed better AOTI and OMMC results compared to fabrics of 100% natural fibre.

Additionally with respect to Anova tests, the number of yarn folds and the weft density did not have any significant effect on both the top ($p > 0.05$) and bottom ($p > 0.05$) overall moisture management capacity results of 100% linen or lin-

en-polyester fabrics at a 95% confidence interval (Table 3).

Air permeability results

Figure 9 shows the air permeability test results of the fabrics. As expected, there was a decreasing trend for the air permeability values of 100% linen and polyester-linen fabrics as the yarn fold and weft density increased. SNK test results (Table 7) indicated that both 100% linen and polyester-linen fabrics produced with different yarn folds at different weft densities possessed statistically different air permeability (mm/s) values. With respect to the number of yarn folds, the highest air permeability was obtained for fabrics of 104/1 tex linen weft yarn – 2153.33 mm/s and for fabrics of 41/1 tex polyester-linen blend weft yarn at a weft density of

Table 7. SNK results of air permeability test results. Note: The different letters (a, b, c) next to the counts indicate that they are significantly different from each other at a significance level of 5%.

Fabrics with linen weft yarn		
Parameter	Air permeability test results, mm/s	
Yarn fold (F)	1	2153.33c
	2	905.11b
	3	608.33a
Weft density (D)	8	1694.22c
	10	1138.67b
	12	833.89a
Fabrics with polyester-linen blend weft yarn		
Parameter	Air permeability test results, mm/s	
Yarn fold (F)	1	1822.22
	2	1007.00
	3	747.56
Weft density (D)	14	1532.33
	16	1164.11
	18	880.33

14 – 1822.22 mm/s. Additionally minimum air permeability values were obtained for fabrics of 104/3 tex linen weft yarn – 608.33 mm/s and for fabrics with 41/3 tex linen-polyester blend weft yarn – 747.56 mm/s. When the fabrics with 100% linen weft yarn at different weft densities were taken into consideration, the highest air permeability value was obtained as 1694.22 mm/s for linen fabrics at a weft density of 8, whereas the lowest air permeability was 833.89 mm/s for linen fabrics at a weft density of 12. The highest air permeability in polyester-linen fabrics was found at a weft density of 14 – 1532.33 mm/s and the lowest air permeability value in polyester-linen fabrics was obtained at a weft density of 18 – 880.33 mm/s. The results are consistent with Umair et. al’s study. where the effect of woven fabric structure on air permeability and moisture management properties was discussed. They declared that the number of picks/cm is the determining factor for the air permeability results of fabrics, and as the number of interlacements among the fabric decreases, the fabric is considered to be less compact, which allows air to pass through more freely [26].

Conclusions

In conclusion, some moisture management properties (wetting time, absorption rate (%/s) and one-way accumulative transport index of the fabrics’ top and bottom surfaces) and the air permeability of 100% linen and 80% Polyester 20% Linen fabrics were influenced significantly (at

0.05% significance level) by the number of yarn folds, weft density and their interaction. Among the 100% linen fabrics, the highest wetting time for the top surfaces was obtained for fabrics with two-folded 100% linen weft yarns, whereas minimum values were found in fabrics with three folded 100% linen weft yarns. The maximum wetting time for both top and bottom surfaces was observed in fabrics with a weft density of 12, whereas minimum values were seen in fabrics with a weft density of 10. Among the polyester-linen fabrics, fabrics with two-folded polyester-linen yarn had maximum wetting times for both surfaces. The maximum wetting times for the top and bottom surfaces were found in fabrics with a weft density of 16 and minimum wetting times belonged to fabrics with a weft density of 18. Fabrics with polyester-linen weft yarn revealed higher bottom-absorption rate (%/s) values when compared with those(%/s) of fabrics with linen weft yarns. Among the 100% linen fabrics, those with two-folded weft yarns revealed the highest absorption rates (%/s) for top and bottom surfaces, whereas fabrics with one-fold weft yarns had the minimum absorption rates (%/s). There was also an increasing trend for the absorption rates (%/s) of the top and bottom surfaces of linen fabrics as the weft density increased from 8 to 12. Among 80% Polyester 20% Linen fabrics, as the number of yarn folds increased, the absorption rates (%/s) of top surfaces exhibited some fluctuation, whereas there was an overall downward trend for those (%/s) of the bottom surfaces of polyester-linen fabrics. The weft density increment resulted in a downward trend for the absorption rates (%/s) of top surfaces; however, this trend was not clear for the bottom surfaces of polyester-linen fabrics.

Among the 100% linen fabrics, the maximum spreading speed (mm/s) was obtained for fabrics with 104/2 tex yarn at a weft density of 8-2.8 mm/s for the top surface and 4.2 mm/s for the bottom surface. When considering the fabrics with polyester-linen weft yarn, the lowest spreading speed (mm/s) belonged to those with 41/2 tex yarn at a weft density of 16 – “0” mm/s for the top surface and “0.3” mm/s for the bottom surface, which means the fabric has very low spreading speed according to the MMT test catalogue (Table 2). Additionally the fabric groups with polyester-linen blend weft yarns had a much higher accumulative one-way transport index when compared to those with 100% linen weft yarn. This

was attributed to the fact that polyester fibres can pass moisture from the inner to outer surface of the fabrics more easily than linen fibres. The general trend for the overall moisture management capacity results (OMMC) of the fabrics (Figure 9) was similar to Figure 8 (one-way accumulated transport index), which indicated that the two terms “AOTI” and “OMMC” were highly interrelated. There was a decreasing trend in air permeability values for both 100% linen and polyester-linen fabrics as the yarn fold and weft density increased. This study has evidenced that the structural properties of fabrics such as the yarn type, yarn count, number of yarn folds, weft density as well as the fibre type and their content ratio (%) may influence the moisture management and air permeability properties of fabrics.

References

- Oğlakçioğlu N, Marmaralı A. Thermal Comfort Properties of Some Knitted Structures. *FIBRES & TEXTILES in Eastern Europe* 2007; 15, 5-6(64-65): 94-96.
- Onofrei E, Rocha AM, Catarino A. The Influence of Knitted Fabrics' Structure on the Thermal and Moisture Management Properties. *Journal of Engineered Fibres & Fibers (JEFF)* 2011; 6(4): 11-22.
- Özdil N, Boz S, Unal ZB, Mengüç GS. Properties of the knitted upper clothes used by primary school children/Proprietatile confecțiilor tricotate purtate în partea superioară a corpului de către elevii de școala primară. *Industria Textila* 2014; 65(5): 287-293.
- Das B, Das A, Kothari VK, Fanguero R, Araújo MD. Studies on moisture transmission properties of PV-blended fabrics. *The Journal of the Textile Institute* 2009; 100(7): 588-597.
- Sharabaty T, Biguenet F, Dupuis D, Viallier P. Investigation on moisture transport through polyester/cotton fabrics. *Indian Journal of Fiber & Textile Research*. 2008; (33): 419-425.
- Kissa E. Wetting and wicking. *Textile Research Journal*. 1996; 66.10: 660-668.
- Su CI, Fang JX, Chen XH, Wu WY. Moisture absorption and release of profiled polyester and cotton composite knitted fabrics. *Textile Research Journal* 2007; 77(10): 764-769.
- Fanguero R, Gonçalves P, Soutinho F, Freitas C. Moisture management performance of functional yarns based on wool fibres. *Indian Journal of Fibre & Textile Research* 2009; 34: 315-320.
- Kyatuheire S, Wei L, Mwasiagi JI. Investigation of Moisture Transportation Properties of Knitted Fabrics Made From Viscose Vortex Spun Yarns. *Journal of Engineered Fibres & Fibers (JEFF)* 2014; 9(3): 151-157.
- Öner E, Atasagun HG, Okur A, Beden AR, Durur G. Evaluation of moisture management properties on knitted fabrics. *Journal of the Textile Institute* 2013; 104(7): 699-707.
- Supuren G, Oglakcioglu N, Ozdil N, Marmarali A. Moisture management and thermal absorptivity properties of double-face knitted fabrics. *Textile Research Journal* 2011; 81(13): 1320-1330.
- Selli F, Turhan Y. Investigation of air permeability and Moisture Management properties of the Commercial Single Jersey and Rib Knitted Fabrics. *Journal of Textile And Apparel* 2017; 27(1): pp. 27-31.
- Özdil N, Süpüren G, Özçelik G, Pruchova J. A Study on the Moisture Properties of the Cotton Knitted Fabrics in Single Jersey Structure. *Journal of Textile and Apparel* 2009; 3: 218-223.
- Nazir A, Hussain T, Ahmad F, Faheem S. Effect of knitting parameters on moisture management and air permeability of interlock fabrics. *Autex Research Journal* 2014; 14(1), 39-46.
- Petrulyte S, Baltakyte R. Investigation into the wetting phenomenon of terry fabrics. *FIBRES & TEXTILES in Eastern Europe* 2008; 16(4): 62-66.
- Çeven EK, Gürarda A. An Investigation of Performance Properties of Curtain Fabrics Produced With Different Types of Polyester Yarns. *Journal of Textile & Apparel* 2017; 27 (2): 131-138.
- Mangat M, Hussain T, Bajzik V. Impact of Different Weft Materials and Washing Treatments on Moisture Management Characteristics of Denim. *Journal of Engineered Fibers and Fabrics* 2012; 7, 1: 38-49.
- Midha V, Suresh KS, Nivas KM. Investigation on permeability and moisture management properties of different denim fabrics after repeated laundering. *The Journal of The Textile Institute* 2017; 108(1): 71-77.
- Kavusturan Y, Tiritöglü M. Effect of Ultrasonic Laundry on Moisture Transport Properties of Knitted Fabric. *16th Recent Progress Symposium on Textile Technology and Chemistry*. Chamber of Textile Engineering: 2017, pp. 113-122, Bursa.
- AATCC 195. Liquid Moisture Management Properties of Textile Fabrics, 2012.
- ISO 9237. Determination of the permeability of fabrics to air, Geneva, Switzerland, 1995
- [http://www.sdlatlas.com/product/203/MMT-\(Moisture-Management-Tester\)](http://www.sdlatlas.com/product/203/MMT-(Moisture-Management-Tester)) accessed on 29.07.2017.
- Namlıgöz ES, Coban S, Bahtiyari M I. Comparison of Moisture Transport Properties of the Various woven fabrics. *Journal of Textile & Apparel/Tekstil ve Konfeksiyon*, 2010; 20(2).93-100.
- Özgen B, Altaş S. The Investigation Of Thermal Comfort , Moisture Management And Handle Properties Of Knitted Fabrics Made Of Various Fibres. *Journal of Textile & Apparel/Tekstil ve Konfeksiyon*. 2014; 24(3) pp. 272-278.
- Ozkan E., Kaplangiray B. Investigating Moisture Management Properties of Weaving Military Clothes. *Journal of Engineering and Architecture (Uludağ University)* 2015; 20 (1): 51-63.
- Umair M, Tanveer Hussain T, Shaker K, Nawab Y, Maqsood M, Jabbar M. Effect of woven fabric structure on the air permeability and moisture management properties. *The Journal of The Textile Institute* 2015; DOI: 10.1080/00405000.2015.1054124

Received 15.01.2018 Reviewed 03.04.2018