

Steffen Rittner¹,
Kerstin Speck²,
André Seidel¹,
Mateusz Ewertowski³,
Manfred Curbach²,
Chokri Cherif¹

Development of Loop-Shaped Textile Anchoring Reinforcements Based on Multiaxial Warp Knitting Technology

DOI: 10.5604/01.3001.0014.3800

¹ Technische Universität Dresden,
Institute of Textile Machinery
and High Performance,
Material Technology (ITM),
01062 Dresden, Germany,
e-mail: steffen.rittner@tu-dresden.de,
e-mail: andre.seidel@tu-dresden.de,
chokri.cherif@tu-dresden.de

² Technische Universität Dresden,
Institute of Concrete Structures (IMB),
01062 Dresden, Germany
e-mail: kerstin.speck@tu-dresden.de,
e-mail: manfred.curbach@tu-dresden.de

³ PERI Polska Sp. z o.o.,
ul. Stoleczna 62, 05-860 Plochocin, Poland,
e-mail: Mateusz.Ewertowski@peri.com.pl

Abstract

Due to the General Building Approval granted for the strengthening of steel reinforced concrete structures by means of textile reinforced concrete, the foundation for its introduction into practice was successfully established. It approves textile reinforcements in the form of non-crimp fabrics made of carbon fibre heavy tows with high yarn fineness. Thus, it is aimed at increasing the amount of filaments per roving in order to minimise the number of reinforcing layers required. However, the relation between the surface and cross-sectional area is compromised once fineness is increased, leading to an unfavourable enlargement of anchoring and overlapping lengths. Therefore, a recently concluded research project evaluated if this challenge can be overcome by means of a loop-shaped selvedge. This paper presents the results generated within these investigations, proving the potential of the textile-based solution. Moreover, required machine modifications based on multiaxial warp knitting technology for the integral and continuous manufacturing of anchoring textile reinforcements as well as significant results derived from bonding tests will be introduced.

Key words: textile reinforced concrete, carbon fibre heavy tow reinforcement, anchoring length, overlapping length, multiaxial warp knitting technology.

Introduction

Layered fabric structures have been established as textile reinforcement materials, which are suitable for the strengthening of already existing elements as well as for the construction of new buildings and components. In 2014, the first German General Building Approval (GBA) approved the use of textile reinforced concrete (TRC) for the strengthening of steel reinforced concrete [1-3]. Since then, its application has become more user-friendly and will be extended by future construction approvals. For further information on the application of textile concrete, corresponding material investigations, and dimensioning concepts can be found, for example in [4].

The economical & structural performance capability of textile reinforcements can be

enhanced by means of yarns with higher fineness. Enlarged yarn cross-sections of Carbon Fiber Heavy Tows (CFHT) with a fineness ranging from 3200 to 3600 tex enable higher tensile strengths for each reinforcement layer compared to carbon yarns with lower fineness. For example, these CFHT have been used in basic research projects [5-9] in addition to initial practical applications [10-12]. A textile reinforcement comprising three layers made of 800 tex yarns was utilised to reinforce the hyper parabolic shell roof over the Auditorium Maximum in Schweinfurt, Germany, University of Applied Sciences [13-15]. A single layer of CFHT fabric produced with higher linear density yarns can replace several layers of a textile reinforcement with low fineness and provide a similar load capacity. As a result, manufacturing costs can be

considerably decreased, coupled to more efficient handling at the construction site [16].

However, the use of CFHT is limited by its bond properties [17]. An increase in the amount of yarn filaments leads to a decreased ratio between the surface and cross-sectional area [18], while simultaneously improving the structure's load-bearing capacity. This results in large anchorage and overlapping lengths required to ensure the transfer of tensile forces to the surrounding concrete matrix. These lengths rise from 0.1 m (rovings with a fineness of 800 tex) to about 0.7 m for the currently used reinforcements with flexible coating [1]. Moreover, large bond lengths lead to an enormous material requirement, which would not be needed in terms of statics. To guarantee economic efficiency, very brief overlapping areas are desired. This also applies to components having a limited available area for overlapping or anchoring due to geometrical reasons [19]. In **Figure 1**, possible anchorage and overlapping zones are displayed.

Force transmission in steel-reinforced concrete constructions is based mostly on form fit and, therefore, clearly differs from the bonding mechanisms that affect textile-reinforced concrete structures. Ribbed reinforcing bars provide favourable bonding with surrounding concrete since their profiled surface results in the interlocking of steel and matrix, thus

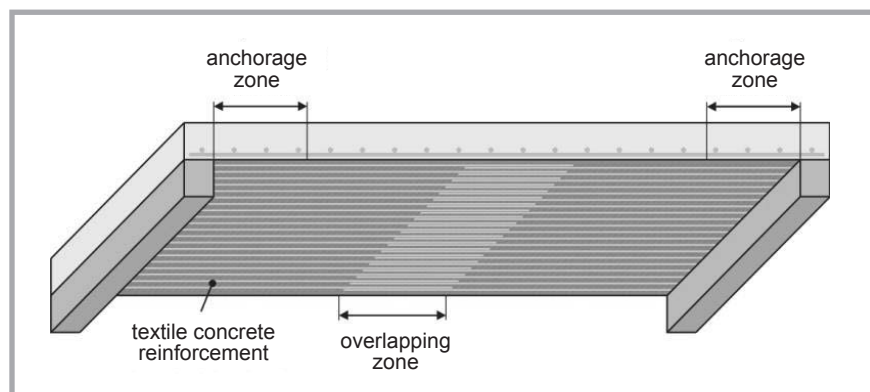

Figure 1. Example of TRC application scenario for the strengthening of a reinforced concrete slab. **Source:** Elena Fleckenstein, modified according to Annett Brückner/IMB.

enabling the transfer of very high shear forces within relatively short lengths [20]. However, in the case of textile-reinforced concrete, force transmission mechanisms are mainly based on adhesive bonding between the yarn surface and concrete as well as interactions between individual yarn filaments (activation of core fibres) [17, 21]. Bonding stress/slippage interactions are typically used to describe composite behaviour, based on which anchorage and overlapping lengths can be determined.

By improving the bonding behaviour of non-crimp structures, and thus minimising the overlapping lengths required, the manufacturing and application of textile reinforcements can be performed more efficiently. Investigations presented in [22-24] evaluated the effects of several factors on bonding properties, including processing, warp and weft yarns, yarn type, degree of coating, additional coating and textile undulation.

Moreover, a project entitled “Anchoring of textile carbon reinforcements” was carried out at the Institute of Textile Machinery and High Performance Material Technology (ITM) in collaboration with the Institute of Concrete Structures (IMB) at TU Dresden. The project aimed at achieving force transmission mechanisms based on form fit, thus minimising anchorage lengths as a result of a targeted textile selvedge design. In [25], the results of anchoring tests using individual carbon yarns are provided. These findings reveal that, compared to straight yarns, elements in the form of hooks and loops allow for anchorage lengths to be reduced to 70% or 50% of the original reference length, respectively

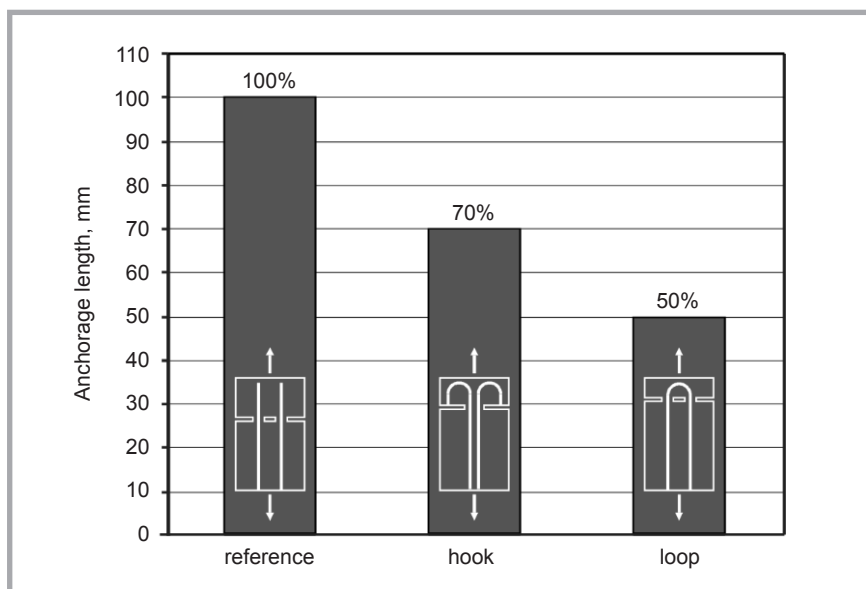

Figure 2. Comparison of anchorage lengths required for yarns with different end geometry, according to [23]. Source: Kerstin Speck/IMB.

(cf. Figure 2). The objective of the project presented was to produce loop-shaped anchoring elements by modifying corresponding non-crimp fabrics. In addition, novel modular machinery enables innovative loop-shaped reinforcements to be produced on a large scale.

Investigations, results and discussion

Manual tests

In the first step, requirements resulting from the fabric structure and building component were determined in terms of the loop geometry (radius of curvature, distance between loops, overlapping areas), and initial structural designs for novel loop reinforcements were created. Subsequently, manual preliminary tests were performed to determine the suitability

of the theoretical structural designs for manufacturing on the available machinery. Special attention was paid to the weft direction of the fabric, as reduced overlapping areas of textile reinforcement lengths in the transverse direction offer the greatest potential for material savings.

Based on individual yarns, basic questions in terms of potential curving radii were evaluated first. Thus, coated as well as uncoated yarns (3300 tex, carbon filament yarn) were investigated. By means of systematic analyses of potential yarn guide elements at deflection points (radius, yarn guide), important information was gained on the processability and anticipated yarn damage in curvature areas. The minimum loop radius allowing for damage-free shaping without fibre abrasion was determined to be 15 mm.

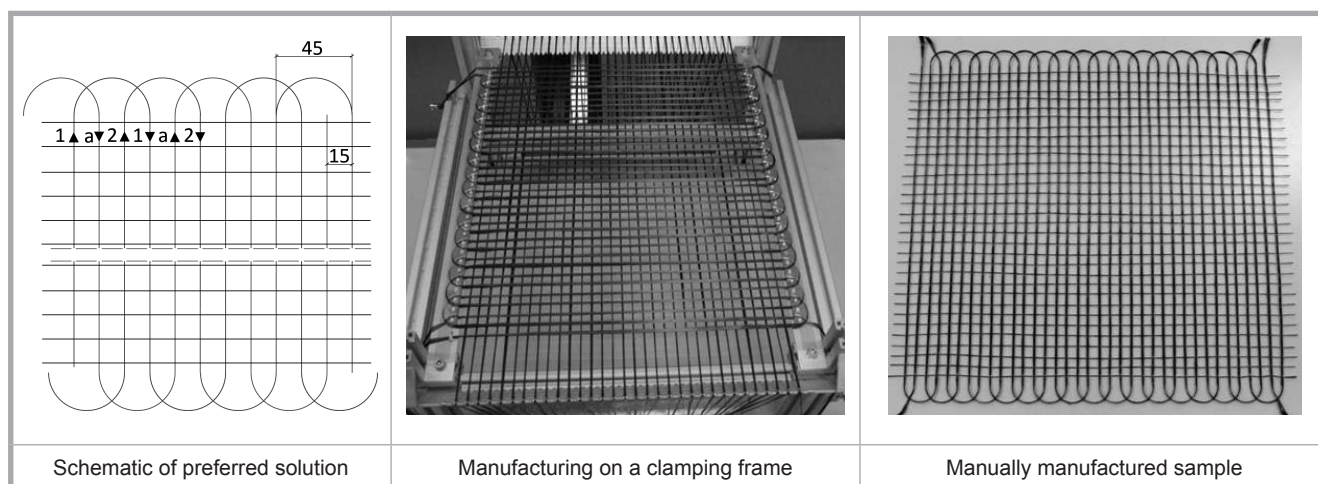

Figure 3. Investigation on the preferred variant for the deposition path of novel loop-shaped non-crimp fabric. Source: André Seidel/ITM.

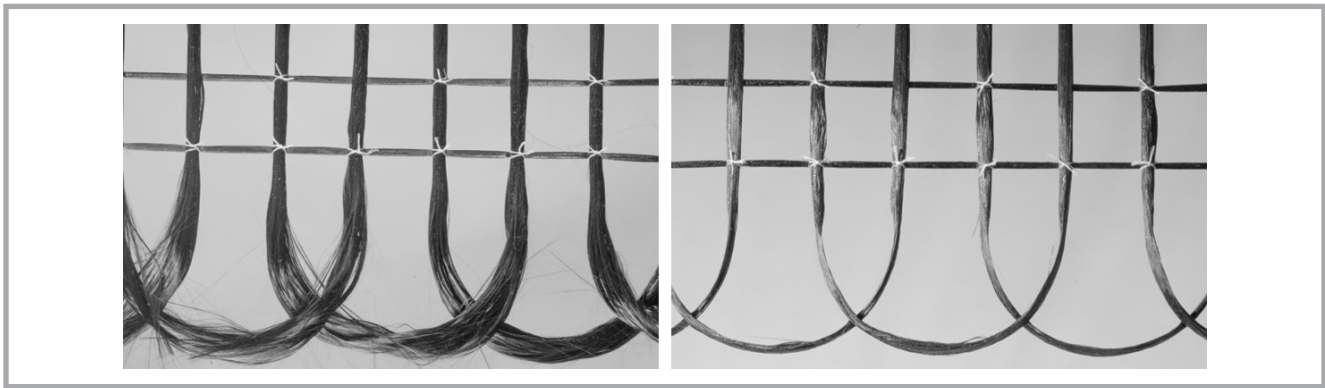

Figure 4. Selvages of manually manufactured looped textiles, uncoated (left) and coated (right). **Source:** Stefan Gröschel/IMB.

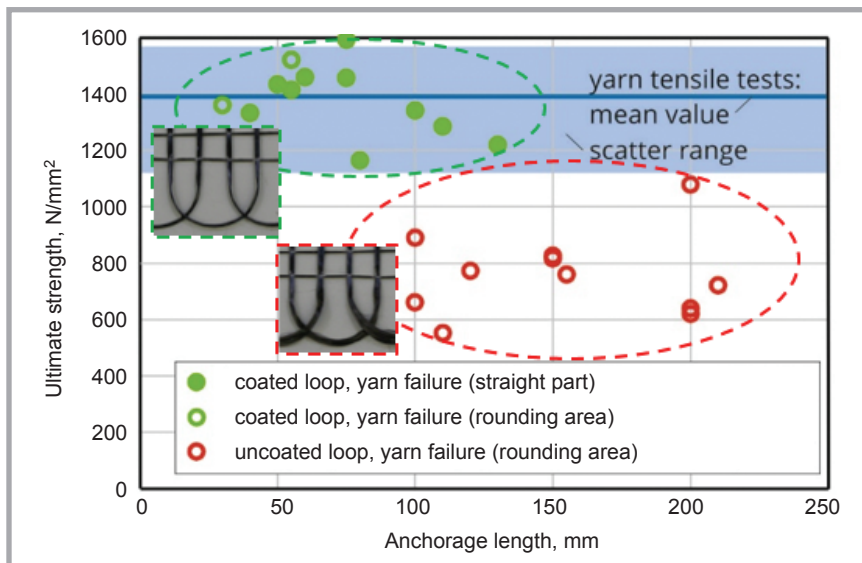

Figure 5. Results of anchorage length test. **Source:** Kerstin Speck/IMB, Steffen Rittner/ITM.

Simultaneously, schematics for weft yarn deposition paths were developed that provide loops on both sides and enable the radiating placement of weft yarns. The laying path seen in **Figure 3** was selected as the preferred variant due to its symmetrical grid geometry, evenly distributed loop pattern, and low yarn accumulation (max. 2) at crossing points.

Based on modified auxiliary equipment, this variant was realised on an experimental scale so that initial fabric samples from carbon filament yarn (fineness 3300 tex) were manufactured, whereby warp and weft yarns were joined manually. Loops with curving radii of 15 mm and 22.5 mm were produced, both with and without coating in the rounding area, see **Figure 4**.

In further experiments, anchoring loops of the manually produced samples previously described were examined. The test specimen production and test-

ing procedure were based on tests previously performed according to [14], which were adapted with regard to the modified reinforcement material. Small-sized specimens were produced by hand lamination using Pagel TF-10 dry mortar [26]. The test specimens were stored in accordance with DIN 18555-3 [27]. Anchorage lengths of up to 250 mm were tested. Investigations revealed that loops alone are insufficient to ensure enough yarn load capacity in the anchoring range of 50 to 100 mm (see **Figure 5**). In the case of uncoated loops, yarn failure occurred in the round area for all anchoring lengths up to 250 mm. Breakage emerged at an early stage, i.e. once half of the total yarn load capacity was reached, so that uncoated loops are considered unsuitable for anchoring purposes. Thus, adding coating to loops is essential so they can bear higher tensile forces as compared to uncoated loops. For example, at an anchoring length of 100 mm, approximately 800 N/mm² was recorded for samples

with uncoated loops, whereas circa 1300 N/mm² was measured for coated loop samples. Even though results vary, there is clearly a correlation between completely coated yarns with a good inner bonding and high tensile strength, according to the interconnection described in [17, 21, 23]; this result was crucial to the machine modifications addressed in the following section.

Machine selection

Transport chains for weft yarns are a key factor in the machine manufacturing process. In principle, both machine types available at the ITM offer the potential to modify transport chains for the shaping of selvage loops. However, the position of the modules must be carefully considered during coating and drying processes. Placing the module outside the transport chain enables the complete coating of the fabric length, including along the edges (based on Malimo 14022), but as the fabric is only tensioned in the warp direction, weft yarns are loose. In contrast, if the module is located within the transport chain, fabric selvages remain uncoated (Malimo 14024) due to the weft yarns being tensioned as well. Due to the required coating of loops (**Figure 5**), machine type Malimo 14022 P2/S2 was selected for further development activities.

Modifications to Malimo 14022 P2/S2 biaxial warp knitting machine

Adjusting the transport chain for weft yarns to be laid was of great significance for production on standard industrial warp knitting machines since it ensures the continuous laying of loops and enables the damage-free removal of the fabric after manufacturing. A coating module and infrared drying unit can be added downstream to the warp knitting machine as part of the process chain. Hence, the

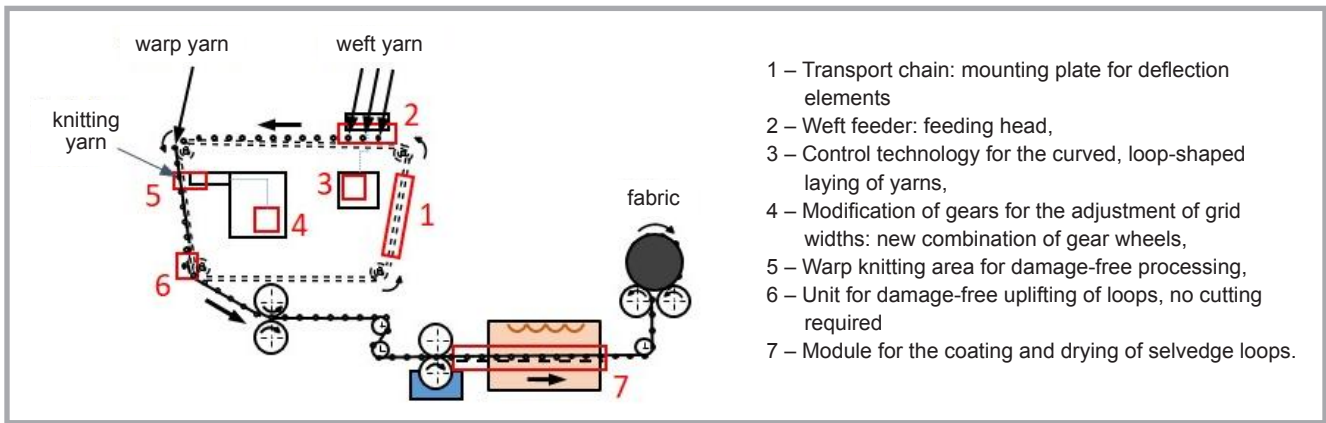

- 1 – Transport chain: mounting plate for deflection elements
- 2 – Weft feeder: feeding head,
- 3 – Control technology for the curved, loop-shaped laying of yarns,
- 4 – Modification of gears for the adjustment of grid widths: new combination of gear wheels,
- 5 – Warp knitting area for damage-free processing,
- 6 – Unit for damage-free uplifting of loops, no cutting required
- 7 – Module for the coating and drying of selvage loops.

Figure 6. Modifications to Malimo 14022 P2/S2 biaxial warp knitting machine (schematic drawing of the process). **Source:** Steffen Rittner/ITM.

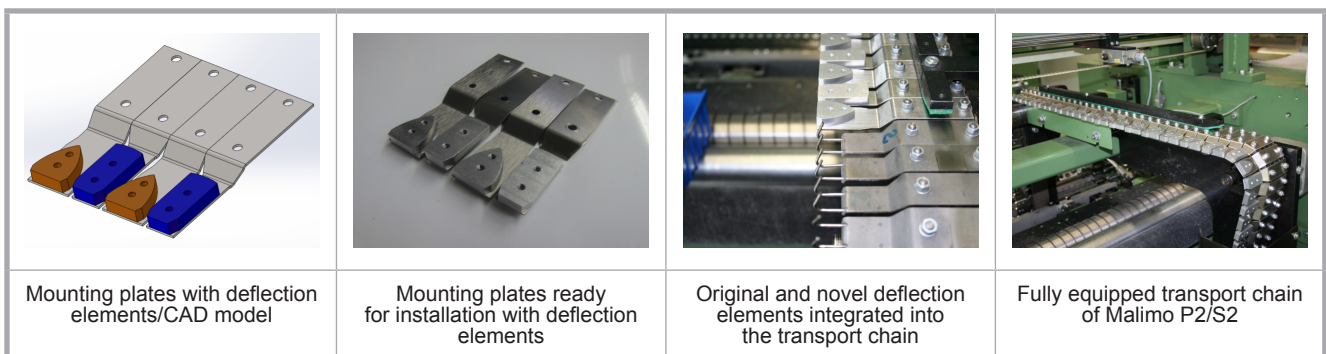

Figure 7. Construction and manufacturing of mounting plates and deflection elements; integration into transport chain. **Source:** André Seidel/ITM.

process-integrated coating and drying of loop-shaped, non-crimp fabrics (on-line coating) can be performed. **Figure 6** shows the components that were further developed.

The deflection elements of transport chains were adjusted to suit the following conditions: due to limited available installation space, the grid dimensions were 25.4 mm, 38.1 mm, and 2 mm for the mounting plates, rounding radius, and plate thickness, respectively. The large curved elements (see **Figure 7**, blue) have chamfered edges on each side of the incoming yarn guide. As a result of complex kinematic motion patterns during weft yarn deposition, the corresponding sections of the transport chain were previously modeled using CAD, and newly developed mounting plates as well as deflection elements were added. After evaluating the CAD simulation, the geometric design of individual deflection element segments was completed. Subsequently, several example elements were manufactured manually in order to test critical sections of the transport chain (deflection in particular) and verify the anticipated machine functionality according to the CAD model. In the next

step, mounting plates and deflection elements were produced in the quantities required and integrated into the transport chain, **Figure 7**.

The modification of the weft yarn carrier posed a particular challenge since it had to be completely redeveloped in accordance with the following parameters, see **Table 1**.

The special feature of this innovation lies in the guide eye position, which should be high enough so that deposited yarn is not damaged when being overpassed, but simultaneously low enough to be compatible with the deflection elements on the transport chain. For this purpose, additional guide elements had to be developed that provide sufficient flexibility to follow the turning of the laying head on its curved path. Following initial test

runs (see **Figure 8**, 1st stage) including subsequent iterative adjustments, the solution achieved (2nd stage) provided high functionality in addition to a satisfactory level of processability. The slide plate made from PTFE material positioned at the laying head ensured gentle yarn guidance and tracking.

After completion of mechanical tasks enhancing the process chain and weft yarn carrier, the machine control and gears were adjusted to synchronise component assemblies according to the new weft yarn laying unit. The control data required were stored using a separate program protocol, which is available as a machine modus termed “loop-shaped textile“. These activities were performed in close collaboration with Karl Mayer Technische Textilien GmbH, Chemnitz, Germany.

Table 1. Framework conditions for weft yarn carrier:

Number of guide eyes for weft yarns	3
Centre distance between guide eyes (Double grid dimension warp), mm	50.8
Max. outer diameter of guide eyes, mm	3.0
Min. inner diameter of guide eyes (for CF yarn 48K), mm	2.4
Max. height of deposition lane between guide eyes, mm	8

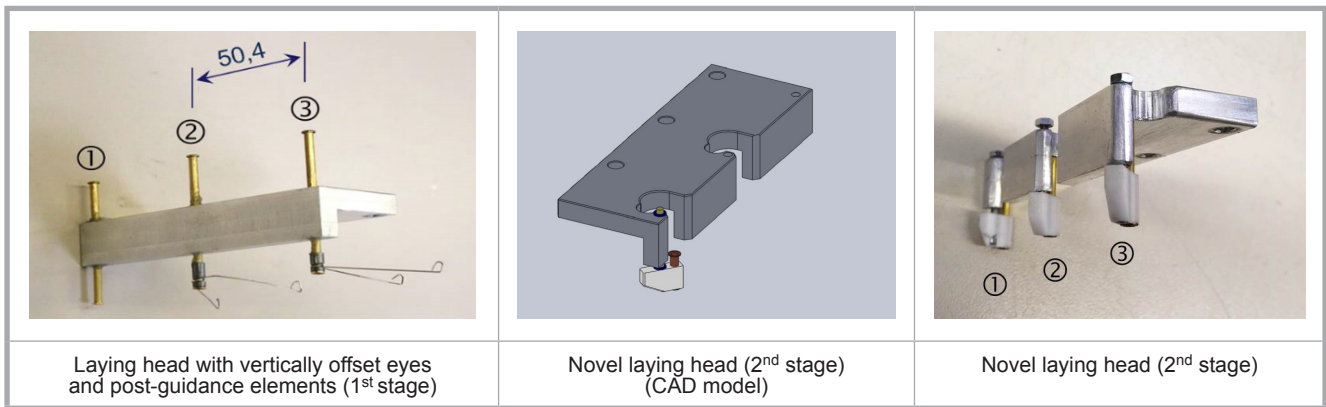

Figure 8. Laying head – two main developmental stages. Source: Steffen Rittner/ITM.



Figure 9. Sample production. Source: André Seidel/ITM (left), Steffen Rittner/ITM (middle, right).

During implementation and testing of the developments described, further measures were required to ensure a reliable supply of yarns as well as their gentle processing. Thus, the following modifications were carried out: (1) development of a holding-down unit for loop-shaped weft yarns that functions simultaneously with the transport chain and (2) modifications to the warp knitting section based on specific plates for the damage-free guiding of loops. Once all construc-

tive-technological advancements were completed, the machine was equipped with carbon rovings. Figure 9 displays the weft yarns within the transport chain and the feeding of warp and weft yarns towards the loop-shaped non-crimp fabric produced on a 10" winding core.

During testing, high process stability in addition to a favorable level of quality were established for pure textile looped non-crimp fabrics.

To ensure the suitability of textile looped non-crimp fabrics for applications in concrete, they must be supplied with an appropriate coating agent to be considered actual textile reinforcement structures. For this, they must be fully impregnated, i.e. coated, and subsequently dried as well as cross-linked (28). Non-crimp fabric structures (without selvedge loops) typically used for building applications are guided through deflection rollers over their width, and simultaneously coating agent is added by means of application and mating rolls. In the final step, the fabric runs through an infrared (IR) drying unit, where water contained in the coating material evaporates and the polymer is cross-linked.

The particular challenge involved in the coating and drying of non-crimp fabrics with selvedge loops lies in securing the shape of loops both during coating agent application as well as during the drying procedure. In this regard, existing machinery and equipment exhibited significant deficiencies, resulting in sagging and distorted loops. Hence, the underlying process was thoroughly analysed and adjusted to meet the requirements of freely hanging loops. The development of special guide plates enabled

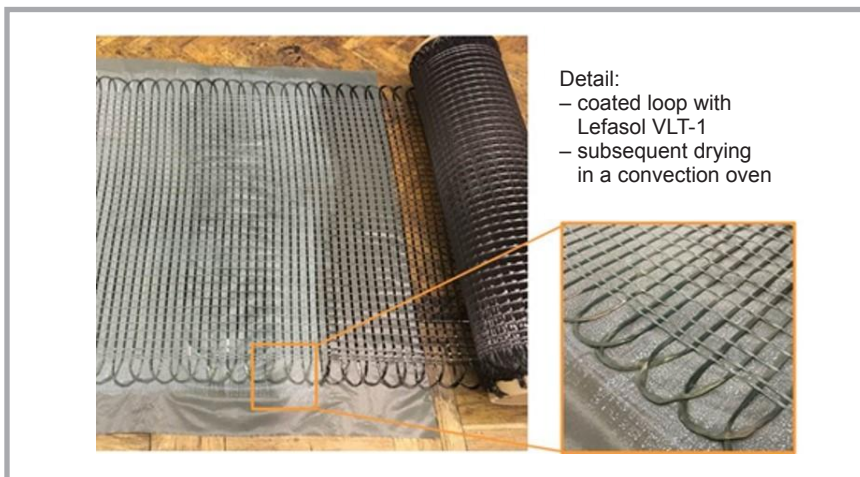

Figure 10. Loop-shaped reinforcements after offline coating and subsequent two-step drying process. Source: Steffen Rittner/ITM.

accurate support of the selvages, i.e. loops, on both sides in their horizontal position, thus avoiding sagging. These plates were made from stainless steel in the form of perforated plates with folded edges, suitable for collecting excess coating material. The shape accuracy of the coated loops was considerably improved by the installation of these guide plates. Simultaneously with online coating tests, manual offline coating tests involving machine-made looped non-crimp fabrics were carried out to evaluate the accuracy and quality of the loop geometry (see **Figure 10**).

These tests were based on the roll coater principle, including top-down application of the coating agent. Drying was completed in a convection oven, thus ensuring temperature-regulated cross-linking of the polymer coating structure. As a result, the laboratory method was able to prove the feasibility of the coating and drying processes for the loop-shaped non-crimp fabrics generated. Functional samples were manufactured after successfully determining all machine and process parameters (see **Table 2**) that are essential to the production of looped non-crimp fabrics, including the application of a coating agent to the textile reinforcement as well as drying and cross-linking.

The feasibility and functionality of the textile structure developed, including its manufacturing process, were proven, while simultaneously forming the basis for further investigations on its bonding properties in concrete. Results revealed that the high structural mechanical potential achieved with previously evaluated, manually produced anchoring textiles can also be met with machine-made structures. Limitations of this enhanced technology were also demonstrated in terms of the coating quality in general and the shape accuracy of loop-shaped structures in particular.

Functional and bonding tests on textile reinforced concrete composites

The suitability of the technical textile loops manufactured was proven in overlapping tests (see **Figure 11**) [29]. In these tests the area investigated can be observed more effectively than in anchorage tests. The size of the specimens was $700 \times 95 \times 8 \text{ mm}^3$ and the measuring length – 300 mm. The textiles to be overlapped were placed directly on top of each other. Loops and straight yarns with different overlap lengths were examined.

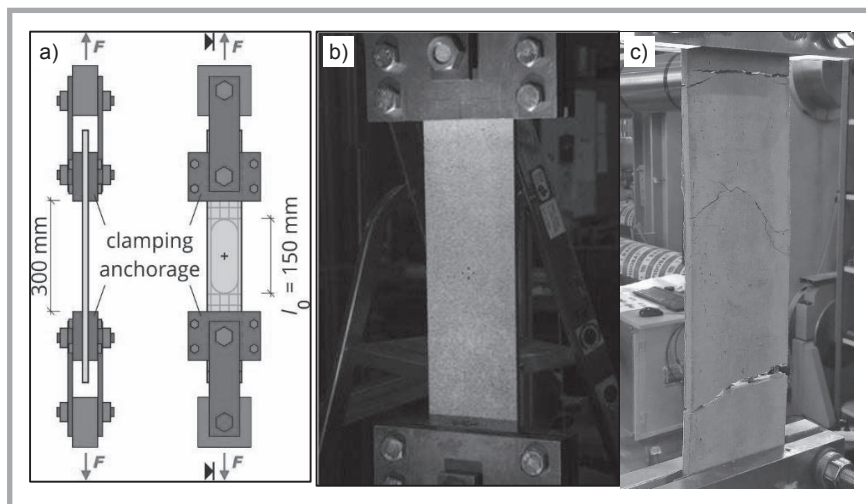

Figure 11. Test setup for overlapping tests with machine-made loops: example of single loop specimen (a), measurement of crack width by means of photogrammetry (b), example of a tested and broken specimen (c). **Source:** Elena Fleckenstein/IMB (a, b), Franz Bracklow/IMB (c).

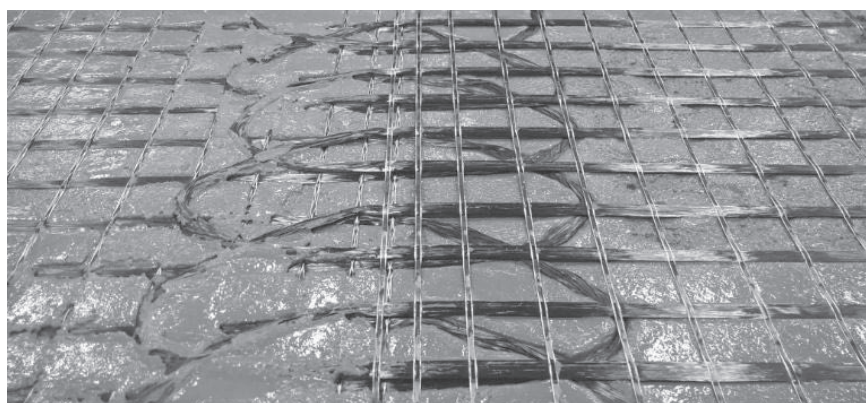

Figure 12. Overlap joint for structural component tests. **Source:** Franz Bracklow/IMB.

For these experiments, individual loops were first excised from the machine-made textile reinforcement (roll). The width of the sample corresponded to four times the yarn spacing so that the fabric in the sample contained one complete and two cut loops. The textiles were matched so that the last weft yarns lay on top of each other, and therefore the transverse reinforcement content remained constant, see **Figure 12**. This resulted in an overlap length of around 150 mm.

Figure 13 provides results of the overlapping experiments performed. The transmittable force with single loops under these conditions were up to two times higher than the values for overlapping with straight yarns. This verifies that even machine-made loops are able to double the anchorable force, i.e. the anchoring length required can be halved. This clearly suggests that the machine development implemented led to considerable material savings.

Table 2. Material and machine parameters for machine-made textile reinforcement, i.e. 'loop-shaped fabric'.

Material and machine parameters 'loop-shaped fabric'	Specifications
Width of non-crimp fabric, incl. loops, m	1.10
Yarn material weft yarn/warp yarn	CF 48K (3200 tex) / CF 12 K (800 tex)
Distance between yarns, weft yarn/warp yarn, mm	25.4/25.4
Loop diameter, mm	76.2
Loop protrusion after first/last warp yarn, mm	65
Coating agent	Lefasol VLT-1 (styrene-butadiene)
Coating agent content, % (percent by mass)	16

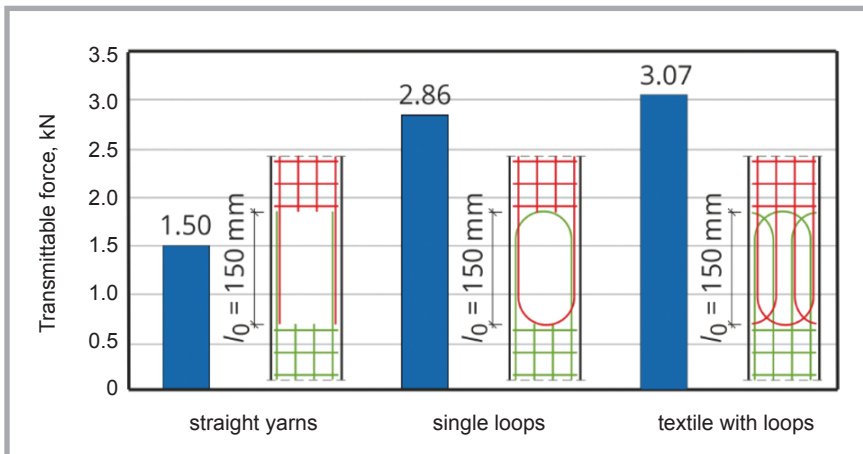

Figure 13. Results of overlapping tests with overlapping length of 150 mm. **Source:** Elena Fleckenstein/IMB, Steffen Rittner/ITM.

Conclusions

The investigations carried out within the research project presented involved the development and technical realisation of innovative, practical textile concrete reinforcements which offer enormous potential for material savings as compared to conventional textile reinforcements due to integrated anchoring and overlapping solutions as well as the resulting significant decrease in overlapping lengths. Reinforcing structures made from Carbon Fiber Heavy Tows allow for the efficient use of their performance potential due to the enhanced bond strength based on improved force transmission. If two loop-shaped fabrics interlock, tensile forces can be transmitted from one textile to another within the few centimetres resulting from the geometry of the loop as a minimum. The minimum overlapping lengths that previously amounted to 700 mm can now be reduced to approximately 150 mm, whereas anchoring lengths can be shortened to 100 mm or less, thus offering great saving potential for carbon reinforcements. Multiaxial warp knitting technology was modified to suit these novel anchoring textile reinforcements, i.e. to enable the process-integrated generation of loop geometries along textile selvages and subsequent consolidation by an online coating procedure.



Acknowledgements

This article presents results of IGF research project 18588 BR of the research association Forschungskuratorium Textil e. V., funded by the AiF within the program for supporting "Industrielle Gemeinschaftsförderung" (IGF) from funds of the Federal Ministry of Economic Affairs and Energy (BMWi)

through a resolution of the German Bundestag. Moreover, we wish to thank the actively involved employees of both participating institutions, namely Dipl.-Ing. (FH) Franz Bracklow and Dipl.-Ing. Fryderyk Krzywinski.

References

- Lorenz E, Schütze E, Weiland S. Textilbeton – Eigenschaften des Verbundwerkstoffs. *Beton- und Stahlbetonbau Spezial* 2015; 110, S1, pp. 30-41.
- Deutsches Institut für Bautechnik (DIBt) Allgemeine bauaufsichtliche Zulassung, Zulassungsnummer: Z-31.10-182, Period of validity until 1. Juni 2021.
- Scheerer S, Schütze E, Curbach M. Strengthening and Repair with Carbon Concrete Composites – the First General Building Approval in Germany. In: *Proc. of SHCC4 – Int. Conf. on Strain-Hardening Cement-Based Composites*, Dresden, Germany, 18.–20.9.2017; Mechtcherine V, Slowik V, Kabele P, Eds.; Springer: Dordrecht, The Netherlands; 2018, pp. 743-751.
- Triantafillou TC. (Ed.). *Textile Fibre Composites in Civil Engineering*. Woodhead Publ. / Elsevier; 2016.
- Curbach M, Ortlepp R. (Eds.). *Sonderforschungsbereich 528 – Textile Bewehrungen zur bautechnischen Verstärkung und Instandsetzung – Abschlussbericht*. Dresden: Institut für Massivbau der TU Dresden, 2012 – URL: <http://nbn-resolving.de/urn:nbn:de:bsz:14-qucosa-86425> (shortened version).
- Hegger J, Will N. (Eds.). *Sonderforschungsbereich 532 – Textilbewehrter Beton – Grundlagen für die Entwicklung einer neuartigen Technologie*: Final report, RWTH Aachen University, 2012.
- Schladitz F, Frenzel M, Ehlig D, Curbach M. Bending Load Capacity of Reinforced Concrete Slabs Strengthened with Textile Reinforced Concrete. *Engineering Structures* 2012; 40: 317-326 – DOI: 10.1016/j.engstruct.2012.02.029.
- Schladitz F, Curbach M. Torsion Tests on Textile-Reinforced Concrete Strength-

ened Specimens. *Materials and Structures* 2012; 45, 1/2, 31-40. DOI: 10.1617/s11527-011-9746-5.

- Brückner A, Wellner S, Ortlepp R, Scheerer S, Curbach M. Plattenbeton mit Querkraftverstärkung aus Textilbeton unter nicht vorwiegend ruhender Belastung. *Beton- und Stahlbetonbau* 2013; 108, 3: 169-178. DOI: 10.1002/best.201200075.
- Helbig T, Unterer K, Kulas C, Rempel S, Hegger J. Fuß- und Radwegbrücke aus Carbonbeton in Albstadt-Ebingen: Die weltweit erste ausschließlich carbonfaserbewehrte Betonbrücke. *Beton- und Stahlbetonbau* 2016; 111, 10: 676-685. DOI: 10.1002/best.201600058.
- Erhard E, Weiland S, Lorenz E, Schladitz F, Beckmann B, Curbach M. Anwendungsbeispiele für Textilbetonverstärkung. *Beton- und Stahlbetonbau* 2015; 110, S1: 74-82. DOI: 10.1002/best.201400124.
- Scheerer S, Chudoba R, Garibaldi M P, Curbach M. Shells made of Textile Reinforced Concrete – Applications in Germany. *Journal of the International Association for Shell and Spatial Structures J.IASS* 2017; 58, 1: 79-93. DOI: 10.20898/j.iass.2017.191.846.
- Diederichs U, Hauptenbuchner B, Mütter U, Weiland S. Restoration of the Hyper Parabolic Shell Roof over the Auditorium Maximum of the University of Applied Science in Schweinfurt, Germany. In: *SANACE 2007, 17th International Symposium REPAIR 2007*, Brno, Czech Republic, 2007.
- Ortlepp R, Weiland S, Curbach M. Restoration of a Hypar Concrete Shell Using Carbon-Fibre Textile Reinforcement Concrete. In: Limbachiya M C; Kew H Y. (Eds.): *Proc. of the Int. Conf. Excellence in Concrete Construction through Innovation*. 9.-10.9.2008 Kingston University (UK), London: Taylor & Francis Group (CRC Press/Balkema), 2009, pp. 357-363.
- Younes A, Seidel A, Rittner S, Cherif Ch, Thyroff R. Innovative textile Bewehrungen für hochbelastbare Betonbauteile. *Beton- und Stahlbetonbau* 2015; 110, S1: 16-21. DOI: 10.1002/best.201400101.
- Rittner S. Mehraxial beschichtete Gelegetstrukturen mit hohem Leistungsvermögen für Bauanwendungen. In: TUDALIT e.V. (Hrsg.): *Proc. 8. Anwendertagung Textilbeton*, 21./22.09.2016 in Augsburg, p. 19.
- Cherif Ch, Diestel O, Engler T, Hufnagl E, Weiland S. Weiterverarbeitungsaspekte und Anwendungsbeispiele. In: Cherif Ch. (Ed.): *Textile Werkstoffe für den Leichtbau*. Berlin, Heidelberg: Springer, 2011, pp. 637-701.
- Koutas L N, Tetta Z, Bournas D A, Triantafillou T C. Strengthening of Concrete Structures with Textile Reinforced Mortars: State-of-the-Art Review. *Journal of Composites for Construction* 2019;

- 3, 1, 20 pages. DOI: 10.1061/(ASCE)CC.1943-5614.0000882.
19. Brückner A, Ortlepp R, Curbach M. Anchoring of Shear Strengthening for T-Beams Made of TRC. *Materials and Structures* 41 (2008) 2, pp. 407-418 – DOI: 10.1617/s11527-007-9254-9.
 20. Lindorf, A., Lemnitzer, L., Curbach, M. Experimental Investigations on Bond Behaviour of Reinforced Concrete Under Transverse Tension and Repeated Loading. *Engineering Structures* 31 (2009) 7, pp. 1469-1476 – DOI: 10.1016/j.engstruct.2009.02.025.
 21. Richter M. *Entwicklung mechanischer Modelle zur analytischen Beschreibung der Materialeigenschaften von textilbewehrtem Feinbeton*. Diss., TU Dresden, 2005.
 22. Lorenz E. Research on the End Anchorage and Overlapping of Textile Reinforcements in Textile Reinforced Concrete. In: Müller H S, Haist M, Acosta F. (Eds.): *Proceedings of the 9th fib International PhD Symposium in Civil Engineering*. Karlsruhe: Scientific Publishing, Karlsruhe Institute of Technology (KIT), 2012, pp. 685–690. DOI: <http://dx.doi.org/10.5445/KSP/1000028287>.
 23. Lorenz E. *Endverankerung und Übergrreifung textiler Bewehrungen in Betonmatrixen*. Diss., TU Dresden, 2014.
 24. Morales Cruz C, Gohil U, Quadflieg T, Raupach M, Gries T. Improving the Bond Behavior of Textile Reinforcement and Mortar Through Surface Modification. In: Brameshuber W. (Ed.): *Proc. of the Ferro-11 and 3rd ICTRC (PRO 98)*, 7.–10.06.2015 in Aachen, Bagnex: Rilem Publications S.A.R.L., pp. 215-223.
 25. Lorenz E, Ortlepp R. Basic Research on the Anchorage of Textile Reinforcement in Cementitious Matrix. In: Oehlers D J, Griffith M C, Seracino R. (Eds.): *Proc. of 9th International Symposium on Fiber-Reinforced Polymer Reinforcement for Concrete Structures (FRPRCS-9)*, 13.–15.7.2009 in Sydney, 2009, Sydney (Australia), Book of abstracts, p. 136 (full paper on CD-ROM, 4 pages).
 26. PAGEL® Spezial-Beton GmbH & Co.KG TF10 TUDALIT® FINE CONCRETE – Technical data sheet, 2019, https://www.pagel.com/all/pdf/gb/TF10_gb.pdf.
 27. DIN 18555-3 *Prüfung von Mörteln mit mineralischen Bindemitteln; Festmörtel; Bestimmung der Biegezugfestigkeit, Druckfestigkeit und Rohdichte*. Beuth-Verlag (1982)
 28. Hahn L, Rittner S, Nuss D, Ashir M, Cherif Ch. *Development of Methods to Improve the Mechanical Performance of Coated Grid-Like Non-Crimp Fabrics for Construction Applications*. FIBRES & TEXTILES in Eastern Europe 2019; 27, 1(133): 51-58. DOI: 10.5604/01.3001.0012.7508.
 29. Schütze E, Bielak J, Scheerer S, Hegger J, Curbach M. *Einaxialer Zugversuch für Carbonbeton mit textiler Bewehrung | Uniaxial tensile test for carbon reinforced concrete with textile reinforcement*. *Beton- und Stahlbetonbau* 113 (2018) 1, s. 33-47. DOI: 10.1002/best.201700074.

Received 15.07.2019 Reviewed 17.04.2020

techtextil
Leading International Trade Fair for
Technical Textiles and Nonwovens

4.–7.5.2021
Frankfurt am Main

**Beyond
innovation.**
techtextil.com

in parallel with:
texprocess

 **messe frankfurt**