

Mulat A. Abteu<sup>1,2,3,4,\*</sup>,  
Carment Loghin<sup>2</sup>,  
Irina Cristian<sup>2</sup>,  
François Boussu<sup>2,3</sup>,  
Pascal Bruniaux<sup>2,3</sup>,  
Yan Chen<sup>4</sup>,  
Lichuan Wang<sup>4</sup>

# Mouldability and its Recovery Properties of 2D Plain Woven Para-Aramid Fabric for Soft Body Armour Applications

DOI: 10.5604/01.3001.0013.4468

<sup>1</sup> "Gheorghe Asachi" Technical University of Iasi,  
Faculty of Textile,  
Leather and Industrial Management,  
Iasi, Romania  
\* e-mail: abteu.mulat@tuiasi.ro  
\* e-mail: mulat\_a@yahoo.com

<sup>2</sup> University of Lille 1,  
Lille, France

<sup>3</sup> Ecole Nationale Supérieure des Arts  
et Industries Textiles,  
GEMTEX,  
Roubaix, France

<sup>4</sup> Soochow University,  
College of Textile and Clothing Engineering,  
Suzhou, China

## Abstract

*Mouldability, along with other mechanical properties, is a very crucial material parameter in various technical textile applications, from composites to soft body armour products. Moreover, the mouldability and recovery behaviours of the material will be affected by various internal and external parameters before, during and after the forming process. The current research particularly tried to study the effects of blank-holder pressure (BHP) and the number of layers not only on the moulding characteristics but also on the recovery behaviour of plain woven p-aramid fabrics made from a high-performance yarn with a linear density of 930 dTex. Samples with various numbers of layers were arranged in the same orientation for the moulding process. The moulding approach utilised a specific moulding device in a low-speed forming process and a predefined semi-hemispherically shaped punch for all specimens. Various important dry textile material moulding characteristics and, most importantly, the moulding recovery properties, such as warp and weft direction drawing-in recovery, center high-point recovery, shear angle recovery etc. were investigated.*

**Key words:** mouldability, moulding recovery, woven p-aramid fabrics, fabric layers; soft body armour.

[4-6]. Recently, the moulding process has also been widely applied in different complex industrial manufacturing processes to fit the three-dimensional shape of the final product instead of cutting and stitching planar textile fabrics. Due to its ability of maintaining material integrity, the process also increases both the material production efficiency and mechanical properties of the final product parts. However, in order to achieve such 3D shapes, the mouldability property of the specific textile material plays a great role. Mouldability mainly comprises shear deformations where the shearing angle between warp and weft yarns is changed at the crossover points at a macro-scale level [7-9]. Fabric mouldability is largely constrained by the freedom of yarn relative movement within the fabric under small shearing force. Various simulation models have been developed and used [10-12] for the prediction and visualisation of wrinkle formation on the surface of fabric reinforcement. For example, in the development of soft ballistic vests and helmet shells [13], the material should have greater properties in terms of dynamic absorption, the strength-to-weight ratio and modulus as well as good bending and mouldability properties to fit the three-dimensional body shape [9]. In addition, female body armour panel design through the moulding method has become very popular, which helps to create a seamless frontal front by mimicking the bust area without the need of cut-and-stitch methods. This ultimately gives bet-

ter comfort, fitness and ballistic protection than any other design methods [14]. However, due to the lack of a standard test for mouldability [15, 16], many researchers have tried to carry out various experimental, numerical and theoretical investigations to understand the mouldability behaviour of material using different methods. Various researchers have studied the formability property as well as various parameters of 2D [17-20] and 3D [21-24] dry multi-layer woven fabrics and textile reinforced composite laminates. For instance, the various layers of 2D, UD and 3D woven or non-woven fabrics are stitched together in different forms to design ballistic protective soft ballistic vests with better ballistic protection along with good flexibility. However, only few researchers have used moulding principles to design required shapes especially for soft ballistic vests for better comfort [25-27]. In the current scenario, manufactured pieces of body armour are designed mostly to be worn by men and are uncomfortable and ill-fitting when worn by a female body due to its unique and curvy body shape. Hence, moulding panels which have good mouldability properties along with better ballistic protection would be the solution. However, in the moulding of ballistic material, various factors which will have an effect not only on the material's mouldability properties but also on its ballistic performances should be considered. For example, in the double-curved shape forming process, mouldability depends not only

## Introduction

Various textile technical applications including soft body armour [1, 2], police helmets, composite laminated products etc. have used different piled, joined and stitched multi-layer two dimensional (2D) p-aramid fabrics in different forms

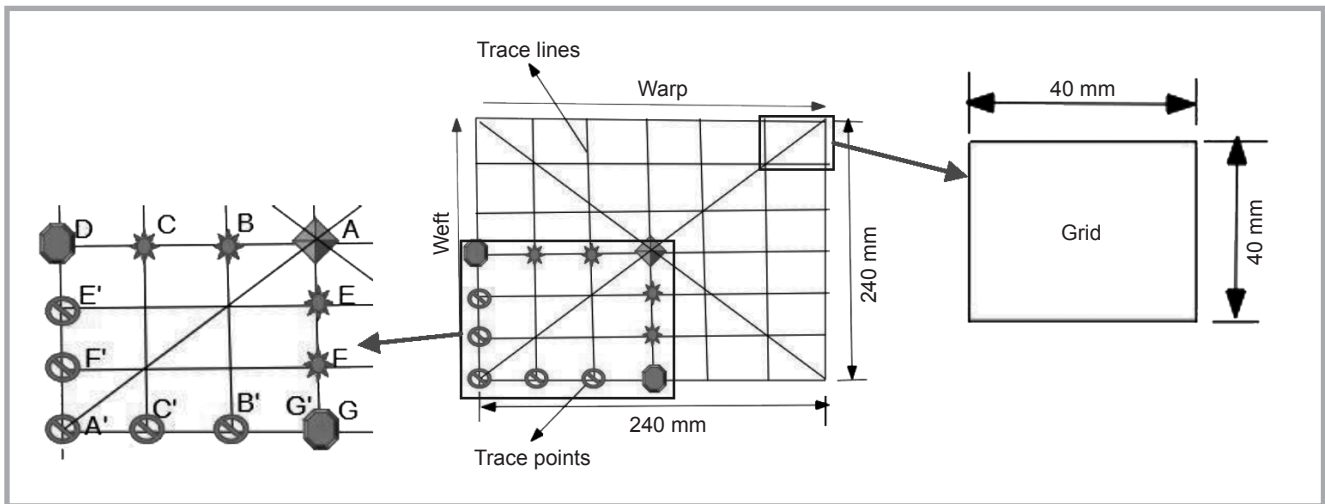

Figure 1. Schematic model view of sample preparations for preforming.

on the preform structure, such as the type of material, fabric structure, and number of layers, but also on forming parameters such as tool loads, blank holder pressure and temperature [12, 28]. A thicker and dense fabric layer provides a uniform moulded surface rather than a thinner and less dense angle interlock fabric layer during the moulding process [29]. During the moulding of chain stitched non-crimp fabrics, different blank holder forces (BHF) ranging from 0.5 to 61.4 kgf were applied to observe their effect. The result clearly shows that BHF positively affects the local change in the fibre angle; i.e., the asymmetrical shear deformation in non-crimp fabrics (NCFs) becomes more symmetrical inside the blank holder area. Another study [30] also investigated the formability of two-layered thermoplastic reinforced fabric laminates with different fibre orientations which are deformed using a hemispherically shaped punch. The result showed that the number of wrinkles strongly depends on the fabric lay-up inside the laminate. Increasing the orientation between the yarns of different plies decreases the formability. A drastic decrease in formability was also noticed when the relative orientation between two neighbouring fabrics increases. This phenomenon is triggered by the increasing difference in local deformation and the high friction coefficient between neighbouring plies.

The main aim of this paper was to investigate the moulding and its recovery characteristics of 2D woven fabrics for various technical applications. The study mainly focuses on the effect of the layer number and blank-holder pressure during the moulding process.

## Experimental

Different researchers have exploited various materials and carried out different kinds of investigations on their important characteristics before using them in different applications, i.e. soft body armour. Among those parameters, the mouldability of the material plays a great role mostly related to the fit and comfort for the final wearer. Even for female body armour the material has to be more flexible without affecting its mechanical performance in order to accommodate curvy body shapes i.e. the bust area. Meanwhile the mouldability property of the textile material is affected by many parameters, including the sample holding pressure and number of layers used. This parameter has to be investigated and analysed through the slow stamping process.

### Materials and sample preparations

2D, UD & 3D high performance fabrics and their composites which can be moulded into 3D shapes are currently applied in many technical products, including soft body armour. This can be possible by eradicating the cutting of planar textile fabrics to fit three-dimensional shapes in the manufacturing process. This process not only increases the productivity of the material fabrication but also enhances the mechanical properties of specific parts for certain applications. This is due the fact that the integrity of the yarn inside the textile material will be more sustained through the entire material. For our research purposes, commonly used plain woven p-aramide fabrics (Twaron CT-709) were specially selected for the development of female soft body armour due to their moulda-

bility; obtained from the Teijin company. The fabric weight was 200 g/m<sup>2</sup>, made with high-performance yarn of 930 dtex linear density, possessing 105 yarn/10 cm in both the weft and warp directions. Four different samples incorporating various layers of fabrics were cut and prepared from 2D plain woven fabric (received from the Teijin company). The different fabric layers of the samples were arranged in the same orientation/direction (0°/90°) for all the samples without the use of any kind of stacking or stitching methods. However, the edges of the panels were gripped using tape to stabilise the layer and protect the fabric edge from yarn fraying during preforming. The different samples prepared were incorporated and prepared using one (01), five (05), ten (10) and fifteen (15) layers of the fabrics mentioned, designated as L-01, L-05, L-10 and L-15 respectively. Moreover, each sample (one, five, ten and fifteen layers) was tested for the moulding property at different blank-holder pressure values, such as 0.1, 0.2 and 0.3 MPa to analyse its effect. The sample fabric was cut and prepared with specific dimensions, as shown in *Figure 1*.

The samples were equally divided into different regions with various indicator points and tracing lines, as indicated in *Figure 1*, in order to easily follow the different phenomena during and after the moulding process.

### Moulding equipment and procedures

#### Moulding machine set up

The moulding bench used for this study, shown below in *Figure 2.a* and *2.b*, is a laboratory based GEMTEX, composed of a static blank holder, an open

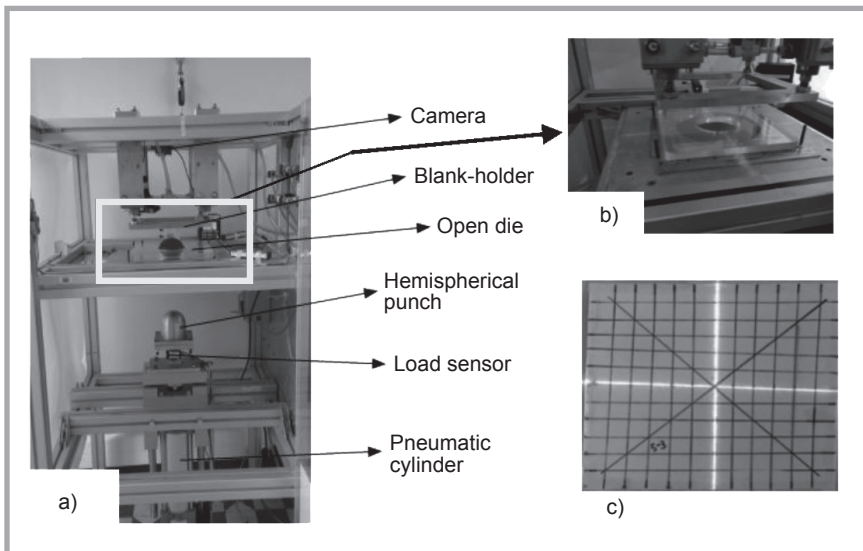

**Figure 2.** a) Dry moulding pneumatically based bench, b) zoomed forming area, and c) preform.

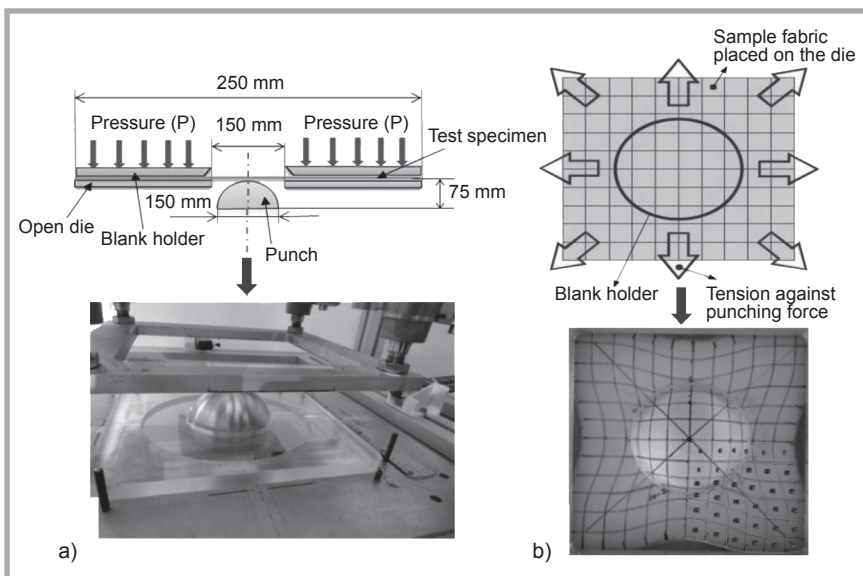

**Figure 3.** a) Hemispherical deep drawing tool geometry and specimen position and b) pressure distribution to form a uniform shape.

die which distributes the pressure provided by the four jacks to the edges of the preform, and a pneumatically based machine [28, 31]. Different shapes of the punch are available for various forms of preform to analyse the different characteristics of the material.

However, a pre-defined 150 mm diameter semi-hemispherical punch was selected and installed on the bench to perform the moulding, ensuring a symmetric double curvature deformation during the process. Moreover, this particular hemispherically shaped punch mostly helped to observe local and global deformations of the different preformed samples by following the different path of yarns in

the structure in both the warp and weft directions, as shown in **Figure 2.c**. Besides direct observation, a camera was also installed and located on the top of the moulding bench to observe and capture the moulding behaviour of the sample during the moulding process.

The pneumatically based four jack under the bench helps to drive a controlled and vertical motion and velocity of the punch in order to deliver the shape required. Meanwhile, a sensor is also installed on the bench to control the different positions of the punch. Besides this, the stress sensor installed helps to measure the forces applied by the punch in preforming

the material during the punching process. The blank-holder pressure knob at the side of the machine also helps to regulate the intended pressure applied on the blank-holder and open die. The blank holder pressure and the velocity of the hemispherical punch should be arranged accordingly prior to moulding [32] and samples must be located exactly in the right position. The blank-holding pressure must also be good enough to hold the sample in all directions in order to prevent either sample folds or yarn breakage.

All the samples were tested at a constant stamping velocity of 45 mm/s. Furthermore, the maximum moulding deformation depth for all specimens was set and specified by the machine to a moulding depth of 65 mm.

The two most important parameters which have to be considered during the forming process are the blank holder pressure and the velocity of the punch. During the punching process, the sample should be appropriately mounted in the proper sample holding position. Moreover, the pressure applied on the blank holder must be properly set in all directions of the sample and be sufficient to maintain the preform, as shown in **Figure 3**. A too high or too low blank holder pressure may result in sample folds and yarn breakage, respectively. Meanwhile the position of the punch, which is below the holder, is controlled by a position sensor, also equipped with a stress sensor to measure forces applied by the punch to the preforming material. Moreover, its motion is controlled by using a piloted four jack mounted below the punch. This device has also been developed to adapt and preform different shapes and sizes of the punch and die.

### Experimental procedures

The samples of intended fabric layers are placed between the blank-holder and open die. While adjusting the sample on the bottom holder, on two sides a laser guiding light (shown in **Figure 2.b**) is applied on the surface to find the proper arrangement and position of the preformed material. The different mouldability phenomena then undergo optical measurement on the top surface of the moulding device during the moulding process. For the different samples of 2D woven sample fabrics, the initial corresponding punch displacement was 65 mm and pressure applied on the blank-holder – 0.1, 0.2

and 0.3 MPa. Finally, for a given pressure of 0.2 MPa, different samples of 2D fabrics with 01, 05, 10 and 15 layers, respectively, were observed and analysed with respect to different moulding characteristics during and after the forming process.

## Results and discussions

In the following few sections, various results of the influences of the number of layers in the panel and blank-holder pressures applied during moulding on the different formability characteristics i.e. punching force and material displacement evolution, drawing-in, through-out-the-thickness variation, the surface shear angle, and material recovery (on drawing-in and deformed height) will be presented.

### Moulding behaviours during the moulding process

While applying moulding to woven fabrics using various complex shapes of the

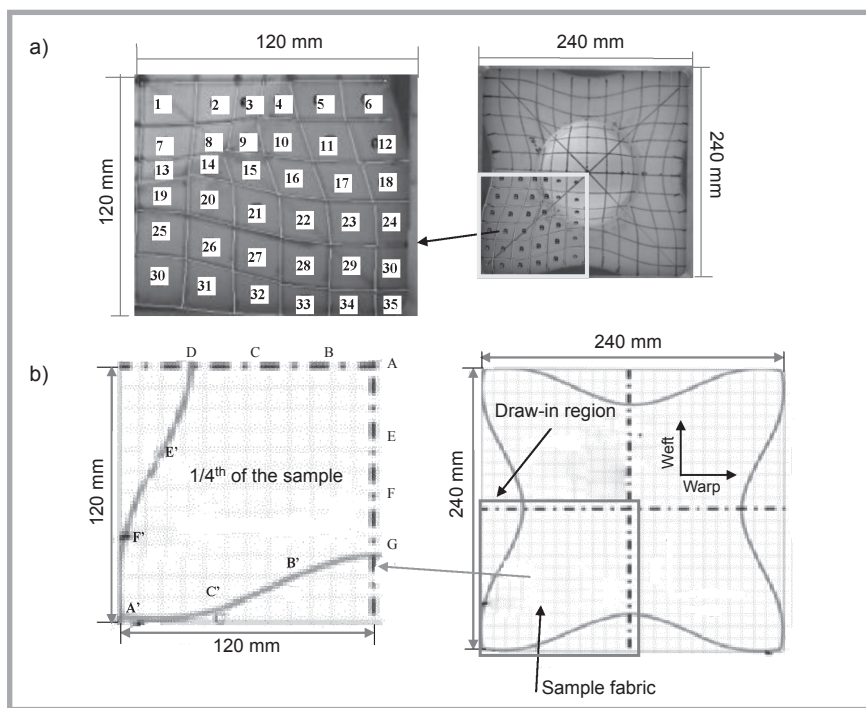

Figure 4. Material drawing-in during deformation: a) photograph and b) schematic diagram.

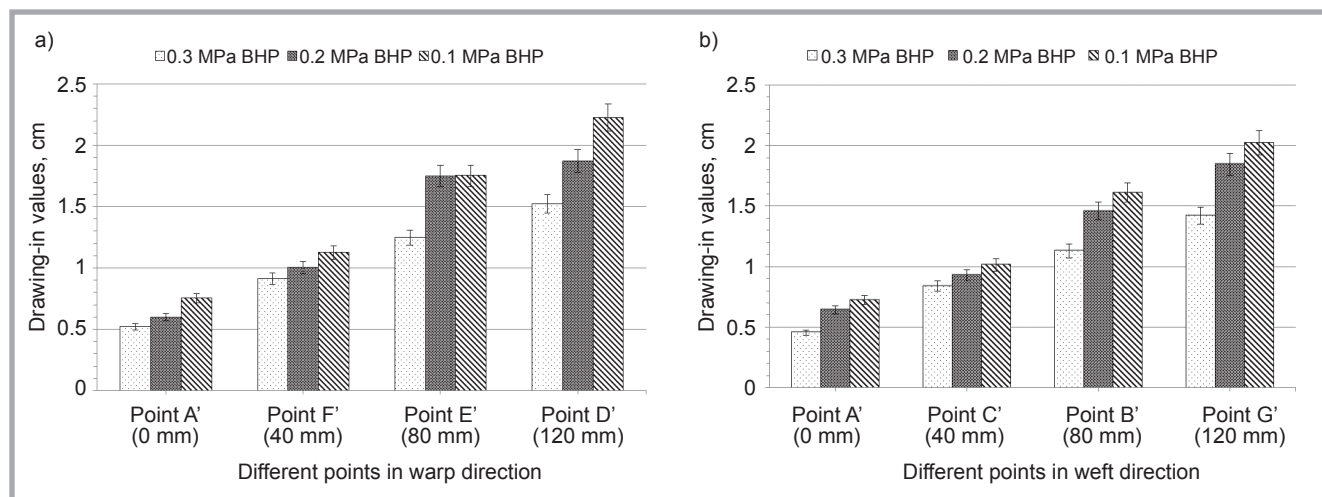

Figure 5. Material drawing-in values of a sample with five layers (L-05): warp a) and weft, b) directions at different BHP.

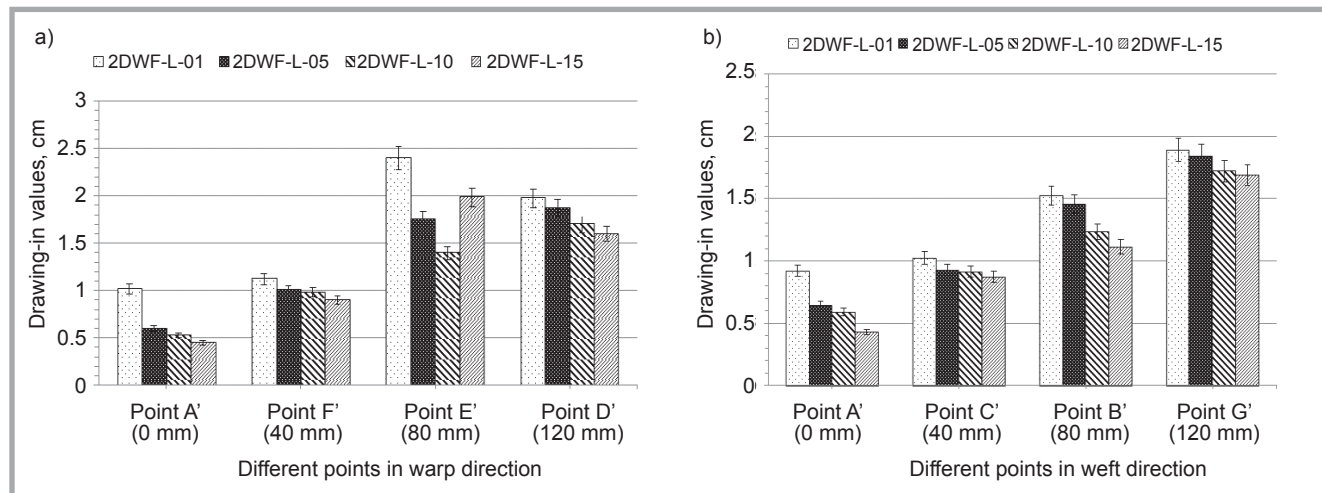
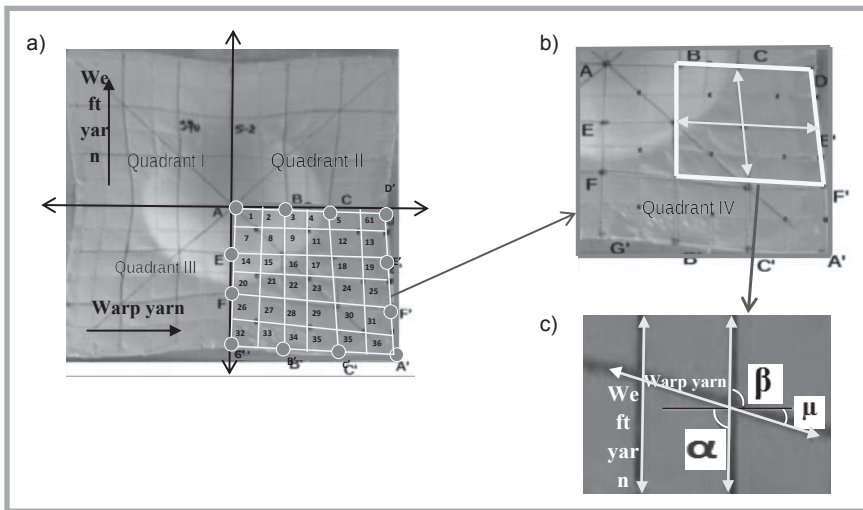
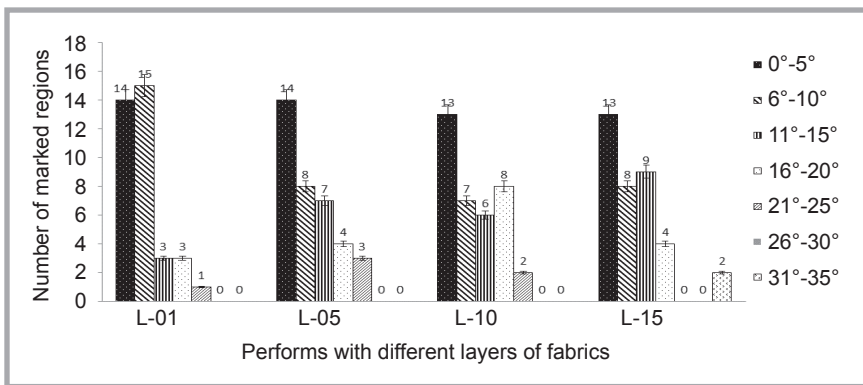

Figure 6. Material drawing-in values of a sample with five layers (L-05): warp a) and weft b) directions at different BHP.



**Figure 7.** In-plane surface shear angle measurement: a) deformed preform, b) representative region (quadrant) and c) in-shear shear angle measurement.



**Figure 8.** Distributions of 0.2 MPa BHP surface shear angle values for samples with different numbers of layers (in quarter regions).

punch, different behavioural phenomena will occur, not only on the top surface but also inside the material, which will probably have an impact on the mechanical properties of the material [15]. Basically, the main defect includes buckling, out-of-plane deformation, and wrinkling [33]. The re-arrangement of the yarns leads to local deformation inside the unit cell of the weave diagram and then spreads to all the fabric structure. If the fabric continues to be deformed, local shear and in-plane compressive forces build up, which then directly influence the angle variation between warp and weft yarns [30]. In order to study the moulding behaviour of the different samples; various characteristics were measured such as the thickness variation, slippage between the external and internal layers, in-plane surface shear angles and material drawing-in values [34].

### Material drawing-in

Material drawing-in is the amount of the expended length of the deformed target in both yarn directions during the moulding process.

For better understanding and analysis of material drawing-in values, we used a quarter portion of the target for both directions due to its uniform values as a result of the force applied by the hemispherical punch, as shown in **Figure 4**.

ImageJ software was applied to measure the different drawing-in values of each region of the sample. 5 uniform layers (sample L-05) were specifically used to see the effect of various blank-holder pressures on the sample's drawing-in values. Based on the result, the drawing-in values of the sample were directly affected by the amount of blank-holder pressure in both the weft and warp directions.

As is clearly observed from **Figure 5**, the higher the values of blank-holder pressure, the lower the drawing-in value of the sample, due to the fact that higher blank-holder pressure helps the edge of the sample to be firmly held, thus preventing the drawing-in phenomenon. This also indicates that the remaining sample region not actually held by the

black-holder will be the region accountable to attain the uppermost drawing-in values. Moreover, comparing the overall deformed regions of the samples, the drawing-in values were found higher around the center than for the rest.

Furthermore, the effect of layer number on the drawing-in values of p-aramid weave fabrics was also evaluated, the results of which are illustrated in **Figure 6**. In this investigation, a blank-holder pressure of 0.2 MPa was applied on the selected sample with a different number of layers. According to the result, with the same blank-holder pressure (0.2 MPa), a significant drawing-in value increment was observed as the number of layers in the sample became lower. The reason behind such a phenomenon would be the punching pressure being distributed to the individual layers, bringing such a significant effect.

### Material surface shear angle measurements

Wrinkling, which also has a strong relationship to the surface shear angle, is one of the most important parameters that should be considered while moulding the target due to its ability to cause material damage. The shear angle is measured mostly between the horizontal (warp) and vertical (weft) yarns. Since we used a hemispherical punch, it was possible to investigate the shear angle values of the quadrant (one fourth (1/4) zones of the deformed plies as representatives of the whole region, as presented in **Figure 7**.

In the process of moulding, it is extremely necessary to consider shear angle measurement and calculation only for sub-areas where no wrinkling is found. In this particular section, in order to observe and analyse the influence of the number of layers on different moulding characteristics, the same blank-holder pressure (0.2 MPa) was utilized for all samples prepared (01, 05, 10 and 15 layers).

Before investigating, the quadrant regions of each sample were divided equally into two sixteen sub-regions. This is basically used for better observation and understanding of the in-plane shear angle while moulding different samples, as shown in **Figure 7.a**. As is illustrated by the measured shear angle values of each region of the different fabric layer samples, minimum shear values were observed on the top and corner edge of the sub-regions. Conversely, maximum

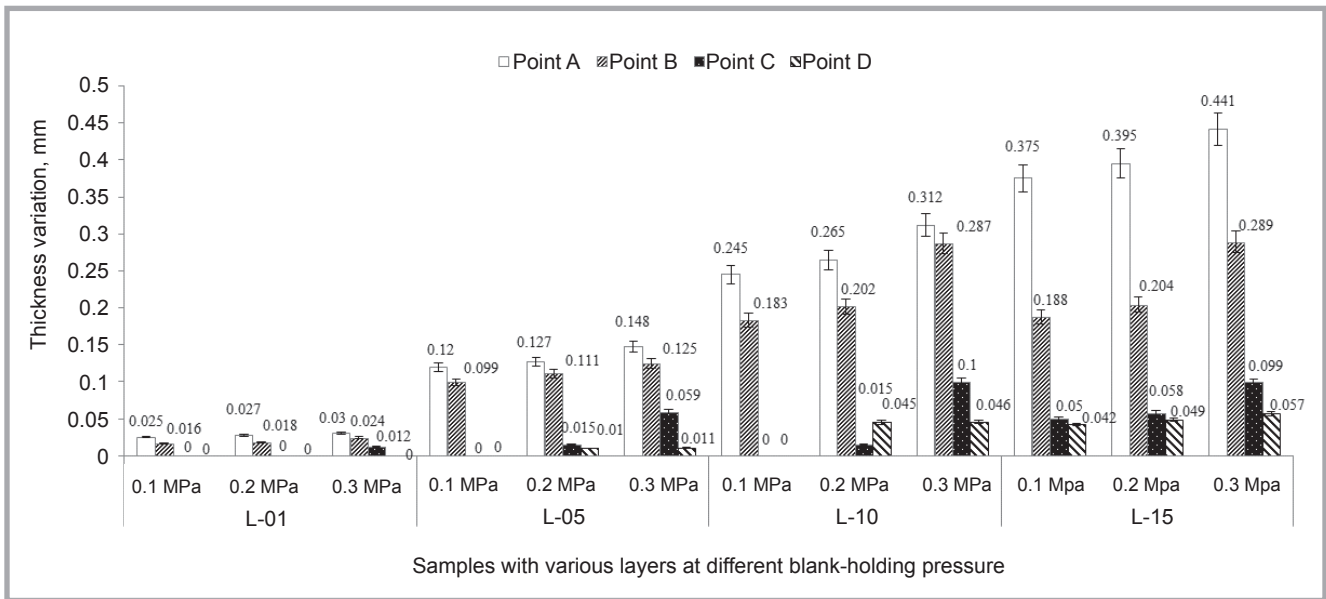

Figure 9. Thickness variation of specimens for different BHP after forming.

shear values were observed on the edge of the deformed regions in the diagonal direction. For better analysis, the quadrant regions were further divided into 36 sub-regions, as shown in Figure 7.a, and the shear angle values of the sub-regions were further segregated into seven categories with a step of 5° for the different samples. As is observed in Figure 8, the distributions of surface shear angle values for samples with different numbers of layers at 0.2 MPa BHP did not reveal a significant shear angle of each and every sub-region of the marked area. However, based on the analysis result, despite some fluctuation and quite unpredictable values, the numbers of layers in the sample showed a linear relation with the amount of the shear angle at the sample surface.

It should also be noted that an insignificant surface shear angle was observed while using a small number of layers during the moulding process and vice versa.

#### Through-the-thickness variation of the material

Material thickness is also affected during the moulding process. For several applications, in order to achieve better mechanical performances, uniform thickness throughout the material is very important. The compactness of fibres due to the pressure applied during moulding will be one of the main reasons. During moulding, the compressibility of the through-the-thickness of the material will be affected at different positions due to

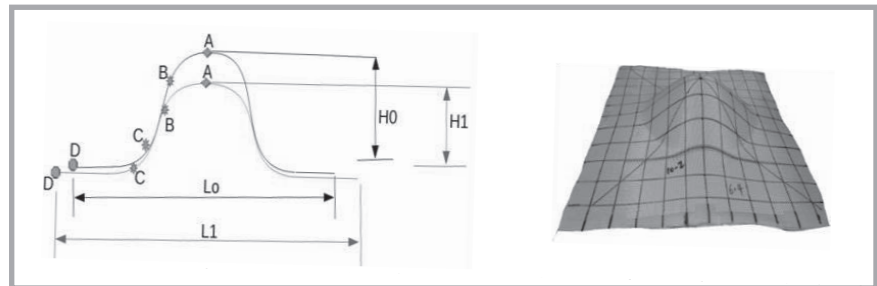

Figure 10. Material recovery after deformation in length and height (side view).

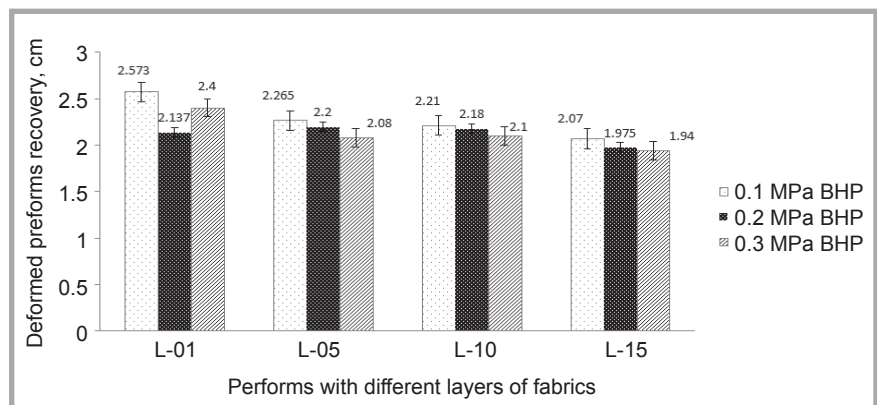

Figure 11. Deformed preform recovery at centre height for different Blank-holder pressures (BHP).

other factors, such as the fibre type, fabric structure, fabric finish, deformation force, number of layers to be deformed, layer bonding type, and blank-holding pressure during deformation. In this study, the thickness variation of different samples (the difference between the minimum and maximum thickness of the fabric) was recorded after the deforma-

tion using a thickness measuring instrument by the contact method. In order to take a precise measurement, various indicator points in different locations in the warp (A, B, C and D) and weft (A, E, F and G) directions were outlined over the top surface of the sample, as shown in Figure 1. The variation in thickness between the original thickness and that af-

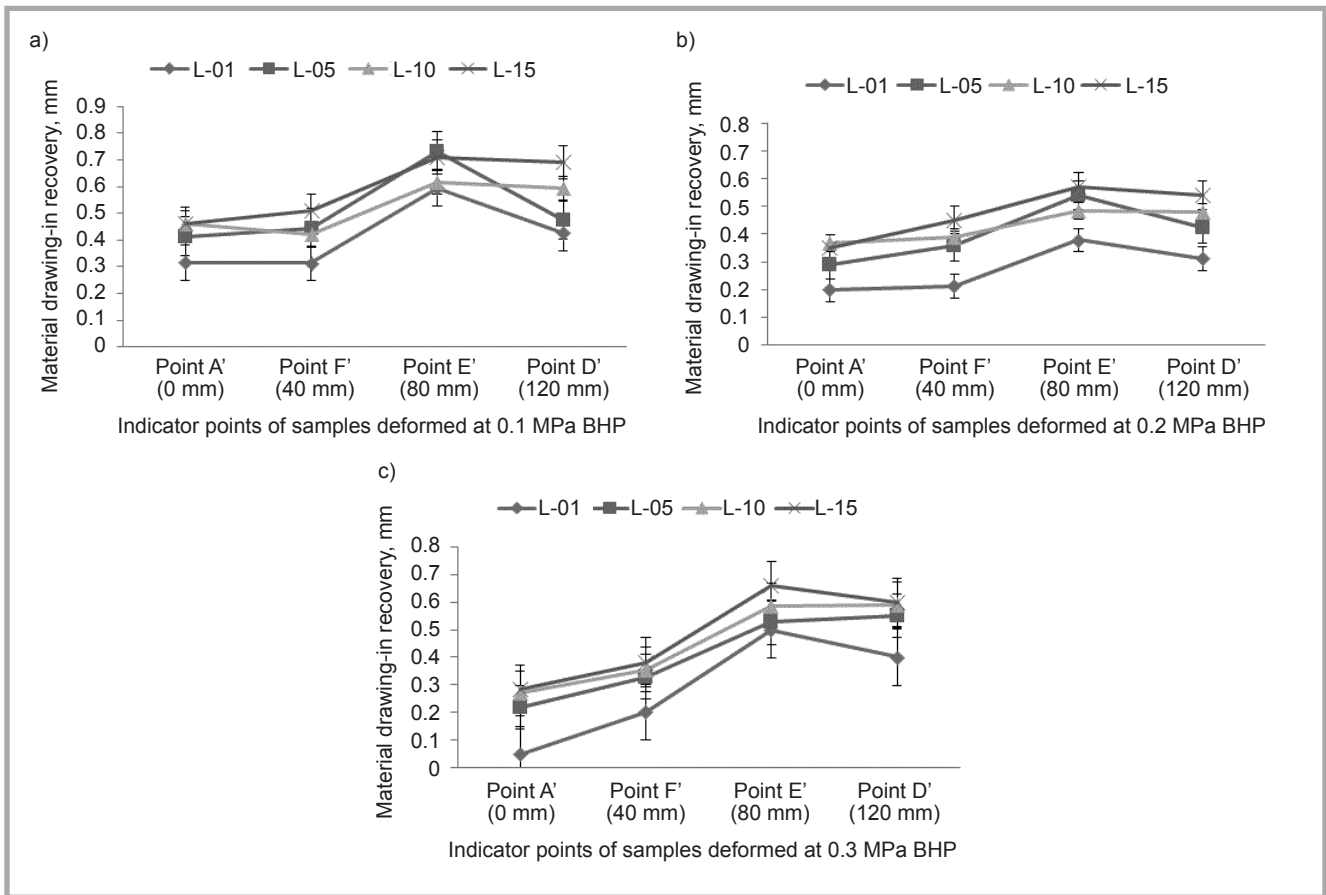

Figure 12. Material drawing-in recovery of the quadrant (1/4th region) of the preform at different Blank-holder pressures (BHP).

ter deformation in the different outlined locations of the preforms was measured and compared, shown in **Figure 9**. Since it is a hemispherical punch, the thickness variation is the same in warp and weft directions. From the measurement data given, the thickness variation within the same layers, which is confirmed by the different blank-holding pressures, revealed that as the pressure applied increases, the thickness variation of the specimen at different ‘indicator’ points increases. This means that the decrease in thickness will be higher at a larger BHP than for a smaller one applied. This is only due to the local area, in which the contacts formed with the material are responsible for the deformation.

This high holding pressure restricted the movements of the neighbouring material and thus did not contribute to the displacement. However, the sample layer found in the lower layer contacting with the forming punch has more thickness variation than that found at the top surface.

The analysis also indicates that in 2D multilayer woven fabric deformation, the total thickness variation is almost equal

to the multiplication of the same amount of sample deformed in single layer samples.

**Material recovery from imposed deformation**

When flexible textile materials are deformed, their recovery behaviour from imposed strain is quite complex. Some quantitative analysis of the recovery behaviour of fibrous assemblies is possible, but complete understanding is not easy to obtain because in this, as in most other problems in textile mechanics, the possibilities for subtle interactions between the elements of the structure are endless [35]. However, in some practical applications of materials containing dry textile, their ability to resist permanent deformation with time under load, to sustain a load when they are deformed by a fixed amount, and/or to recover their initial dimensions after the load is removed, is of great concern. These three behaviours are associated with the material creep, relaxation and recovery, respectively. Unlike most composite materials, the 2D dry woven fabric structure does exhibit these time-dependent behaviours to a significant extent.

For our dry relaxation process after deformation, the performed samples were kept on a flat surface in standard conditions (20 °C at 65% RH) for 24 hours. After deformation, depending on the property of the material (H0, L0), it recovers from its initial shape (H1, L1) in the different dimensions, as shown in **Figure 10**.

The following section will try to analyse and discuss the recovery of the material in the deformed centre height position and in the material’s drawing-in length using different BHP.

**Deformation recovery in centre deformed height**

In this section, the recovery property of different deformed samples at the maximum height (‘indicator’ point A), shown in **Figure 10**, is assessed. In this figure, the deformed curve, illustrated using black colour (higher height), represents the shape of the formed material immediately after deformation; whereas the deformed curve with red colour (lower height) designates the shape of the sample preform after it has been kept in a standard atmosphere for 24 hours. The recovered height ( $H_R$ ) is

the difference between the deformation immediately after deformation and that measured after the sample was kept in standard conditions.

The recovered deformation at the centre height is given by **Equation (1)**:

$$H_R = H_0 - H_1 \quad (1)$$

Where:

$H_R$  – recovered deformation at the centre height,

$H_0$  – deformation immediately after preforming,

$H_1$  – deformation after performing after having been kept for 24 hours in standard conditions.

In the moulding process, the initial maximum displacement,  $H_0$ , was the same (65 mm) for all samples. As is revealed in **Figure 11**, for the majority of all blank-holding pressures (BHP) applied, the material recovery displacements becomes higher at a lower number of layers (L-01) than in the sample with a large number of layers (L-15).

Similarly, even though it is not true for all samples, as the amount of BHP increases for the same sample, the height recovery displacement decreases. This is due to the fact that increasing the pressure of the blank-holder may induce high tension loads on the yarns in certain zones, leading to loss of elasticity, which helps to recover to the original position.

#### **Deformation recovery of material after drawing-in**

The material drawing-in deformation recovery in the warp direction was measured following the different ‘indicator’ points (A’, F’, E’ and D’) plotted on the surface of the material, shown in **Figure 1**. Due to the similar parameters used, it was considered that the deformation and recovery in the warp and weft directions are quite similar. These are due to the same material with similar properties and quite similar deformation in the warp and weft directions. The drawing-in recovery ( $L_R$ ) was the difference in the length measured immediately after deformation and that after it had been kept in standard conditions for 24 hours.

The recovered deformation of the material drawing-in at different ‘indicator’ points is given by **Equation (2)**:

$$L_R = (L_1 - L_0)/2 \quad (2)$$

Where:

$L_R$  – recovered drawing-in after deformation,

$L_0$  – deformation drawing-in immediately after preforming,

$L_1$  – deformation drawing-in after preforming after having been kept for 24 hours in standard conditions.

As is observed from **Figure 12**, the recovery in drawing-in for the given sample with different BHP values in the warp direction was investigated. The graph indicates uniform relationships between the two parameters. With the same BHP, the drawing-in recovery value for the given sample with a large number of layers is more than for that with a small number of layers. This result shows a similar trend for almost all blank-holding pressures.

## ■ Conclusions

In various technical applications the mouldability behaviour and its recovery property are very important and have to be considered since they will play a significant role with respect to the final mechanical properties. However, the mouldability property and recovery of dry multi-layer textile material will be affected by several external and internal factors, among which the material type, type of woven structure, fabric finishing, number of layers, moulding punch conditions such as punch shape, blank-holder pressure, punching velocity, and depth are some of the important ones. The current study investigated the influences of the number of layers along with various blank-holder pressures on its different moulding behaviour and recovery. According to the investigation, both the blank holder pressure applied to clamp the specimen and the number of layers used in the sample panel play a significant role, not only with respect to the mouldability property but also to the recovery behaviours of the samples. For instance, as the holding pressure of the blank-holder increases, the drawing-in value decreases, and the region which is not held by the holder is solely responsible for the deformation. Whereas at every blank holder pressure applied to the material, the recovery after deformation decreases as the number of layers in the specimen increases. Regarding the surface shear angle, it becomes more severe as the number and pressure applied increases during moulding. Similarly, even though it is not true for all samples, as the amount

of blank-holding pressure increases on the same sample, the height recovery displacements decrease. This is due to the fact that increasing the pressure of the blank-holder may induce high tension loads on the yarns in certain zones, leading to loss of elasticity, which helps to recover to the original position. ▣

## Acknowledgements

*This work was carried out as part of the Sustainable Management and Design for Textiles (SMDTex) Project, funded by the European Erasmus Mundus Program.*

## Compliance with Ethical Standard

*The Authors declare there is no financial and/or relevant interest that influenced the study. The study also gives consent to any involvement therein .*

## References

1. Stempień Z. Effect of Velocity of the Structure-dependent Tension Wave Propagation on Ballistic Performance of Aramid Woven Fabrics. *FIBRES & TEXTILES in Eastern Europe* 2011, 19, 4 (87): 74-80.
2. Cheng-Kun Chu, Yu-Liang Chen. Ballistic-proof Effects of Various Woven Constructions. *FIBRES & TEXTILES in Eastern Europe* 2010, 18, 6 (83): 63-67.
3. Bilisik K. Two-Dimensional (2D) Fabrics and Three-Dimensional (3D) Preforms for Ballistic and Stabbing Protection: A Review. *Text Res J* 2016; 0: 1-30.
4. Abtew MA, Boussu F, Bruniaux P, et al. Forming Characteristics and Surface Damages of Stitched Multi-Layered Para-Aramid Fabrics with Various Stitching Parameters for Soft Body Armour Design. *Compos Part A. Appl Sci Manuf* 2018; 109: 517-537.
5. Abtew MA, Boussu F, Bruniaux P, et al. Experimental Investigation of Effects of Stitching Orientation on Forming Behaviors of 2D P-Aramid Multilayer Woven Preform. *In: AIP Conference Proceedings*. 2018, pp. 1-8.
6. Abtew MA, Bruniaux P, Boussu F, et al. A Systematic Pattern Generation System for Manufacturing Customized Seamless Multi-Layer Female Soft Body Armour Through Dome-Formation (Moulding) Techniques Using 3D Warp Interlock Fabrics. *J Manuf Syst* 2018; 49: 61-74.
7. Zhong T, Hu H. Formability of Weft-Knitted Fabrics on a Hemisphere. *Autex Res J* 2007; 7: 245-251.
8. Bekampiene P, Domskiene J. Experimental Analysis of the Influence of Stress Concentrators on the Buckling of Woven Materials Under Uniaxial Tension. *Int J Mater Form* 2010; 3: 211-214.



9. Mozafary V, Payvandy P, Bidoki S, et al. Predicting the Influence of Seam Design on Formability and Strength of Nonwoven Structures Using Artificial Neural Network. *Fibers Polym* 2013; 14: 1535-1540.
10. Robertson RE, Chu TJ, Gerard RJ, et al. Three-Dimensional Fiber Reinforcement Shapes Obtainable From Flat, Bidirectional Fabrics without Wrinkling or Cutting. Part 1. A Single Four-Sided Pyramid. *Compos Part A. Appl Sci Manuf* 2000; 31: 703-715.
11. Potter K. Beyond the Pin-Jointed Net: Maximising the Deformability of Aligned Continuous Fibre Reinforcements. *Compos – Part A. Appl Sci Manuf* 2002; 33: 677-686.
12. Mack C, Taylor HM. 39 – The Fitting of Woven Cloth to Surfaces. *J Text Inst Trans* 1956; 47: T477-T488.
13. Fejdyś M, Łandwajt M, Habaj W, Struszczyk MH. Ballistic Helmet Development Using UHMWPE Fibrous Materials. *FIBRES & TEXTILES in Eastern Europe* 2015; 23, 1(109): 89-97.
14. Abteu MA, Bruniaux P, Boussu F, et al. Development of Comfortable and Well-Fitted Bra Pattern for Customized Female Soft Body Armor Through 3D Design Process of Adaptive Bust on Virtual Mannequin. *Comput Ind* 2018; 100: 7-20.
15. Chen X, Lo W-Y, Tayyar AE. Mouldability of Angle-Interlock Woven Fabrics for Technical Applications. *Text Res J* 2002; 72: 195-200.
16. Boussu F, Legrand X, Nauman S, et al. Mouldability of Angle Interlock Fabrics. In: *FCPM, the 9th International Conference on Flow Processes in Composite Materials*. Montréal (Québec), Canada, 2008.
17. Ye L, Daghyani HR. Characteristics of Woven Fibre Fabric Reinforced Composites in Forming Process. *Compos Part A* 1997; 28: 869-874.
18. Dufour C, Boussu F, Wang P, et al. Forming Behaviour of 3D Warp Interlock Fabric to Produce Tubular Cross Composite part. In: *14th AUTEX World Textile Conference*. Bursa, Turkey, 2014.
19. Hu J, Jiang Y. Modeling Formability of Multi-axial Warp Knitted Fabrics on A Hemisphere. *Compos Part A Appl Sci Manuf* 2002; 33: 725-734.
20. Dufour C, Wang P, Boussu F, et al. Experimental Investigation About Stamping Behaviour of 3D Warp Interlock Composite Preforms. *Appl Compos Mater* 2014; 21: 725-738.
21. Lee JS, Hong SJ, Yu W, et al. The Effect of Blank Holder Force on the Stamp Forming Behavior of Non-Crimp Fabric with a Chain Stitch. *Compos Sci Technol* 2007; 67: 357-366.
22. Zhu B, Yu TX, Zhang H, et al. Experimental Investigation of Formability of Woven Textile Composite Preform in Stamping Operation. *Composites* 2008; 1: 969-972.
23. Cai Z, Yu JZ, Ko FK. Formability of Textile Preforms for Composite Applications. Part 2: Evaluation Experiments and Modelling. *Compos Manuf* 1994; 5: 123-132.
24. Yu JZ, Cai Z, Ko FK. Formability of Textile Preforms for Composite Applications. Part 1: Characterization Experiments. *Compos Manuf* 1994; 5: 113-122.
25. Chen X, Yang D. Use of Three-dimensional Angle-interlock Woven Fabric for Seamless Female Body Armor: Part II: Mathematical Modeling. *Text Res J* 2010; 80: 1589-1601.
26. Boussu F, Bruniaux P. Customization of a Lightweight Ballistic Vest for the Female Form. In: *Advances In Military Textiles And Personal Equipment*. Woodhead Publishing. 2012, pp. 167-195.
27. Mahbub R, Wang L, Arnold L. Design of knitted three-dimensional seamless female body armour vests. *Int J Fash Des Technol Educ* 2014; 7: 198-207.
28. Najjar W, Legrand X, Dal Santo P, et al. Analysis of the Blank Holder Force Effect on the Preforming Process Using a Simple Discrete Approach. *Key Eng Mater* 2013; 554-557: 441-446.
29. Nawab Y, Legrand X, Koncar V. Study of Changes in 3D-Woven Multilayer Interlock Fabric Preforms While Forming. *J Text Inst* 2012; 103: 1273-1279.
30. Vanclooster K, Lomov SV, Verpoest I. On the Formability of Multi-Layered Fabric Composites. *Proc 17th Int Conf Compos Mater*, 2009; 1-10.
31. Najjar W, Legrand X, Pupin C, et al. A Simple Discrete Method for the Simulation of the Preforming of Woven Fabric Reinforcement. *Key Eng Mater* 2012; 504: 213-218.
32. Dufour C, Boussu F, Wang P, et al. Experimental Forming Studies on 3D Warp Interlock Fabrics. *Eccm16 – 16th Eur Conf Compos Mater*.
33. Capelle E, Ouagne P, Soulat D, et al. Complex Shape Forming of Flax Woven Fabrics: Design of Specific Blank-Holder Shapes to Prevent Defects. *Compos Part B Eng* 2014; 62: 29-36.
34. Prodromou AG, Chen J. On the Relationship Between Shear Angle and Wrinkling of Textile Composite Preforms. *Compos Part A Appl Sci Manuf* 1997; 28: 491-503.
35. Skelton J. Textile Materials: Recovery from Imposed Deformation. *Science* (80) 1972; 177: 657-663.

□ Received 15.11.2018      Reviewed 10.05.2019



11<sup>th</sup>

EDITION OF

INTERNATIONAL

CONFERENCE ON

ANALYTICAL

CHEMISTRY

FEBRUARY 24-25, 2020
BERLIN, GERMANY

Analytical Chemistry 2020

