

Mihriban Kalkanci<sup>1,\*</sup>,  
Gülseren Kurumer<sup>2</sup>,  
Hasan Öztürk<sup>3</sup>,  
Mahmut Sinecen<sup>4</sup>,  
Özlem Kayacan<sup>2</sup>

<sup>1</sup>Pamukkale University,  
Buldan Vocational College,  
Denizli, Turkey  
\*E-mail: mkalkanci@pau.edu.tr

<sup>2</sup>Dokuz Eylül University,  
Department of Textile Engineering,  
Izmir, Turkey

<sup>3</sup>Dokuz Eylül University,  
Department of Mechanical Engineering,  
Izmir, Turkey

<sup>4</sup>Adnan Menderes University,  
Department of Computer Engineering,  
Aydın, Turkey

# Artificial Neural Network System for Prediction of Dimensional Properties of Cloth in Garment Manufacturing: Case Study on a T-Shirt

DOI: 10.5604/01.3001.0010.2859

## Abstract

*The purpose of the present study was to estimate dimensional measure properties of T-shirts made up of single jersey and interlock fabrics through artificial neural networks (ANN). To that end, 72 different types of T-shirts were manufactured under 2 different fabric groups, each was consisting of 2 groups: one with elastane and the other without. Each of these groups were manufactured from six different materials in three different densities through two different knitting techniques of single jersey and interlock. For estimation of dimensional changes in these T-shirts, models including feed-forward, back-propagated, the momentum learning rule and sigmoid transfer function were utilized. As a result of the present study, the ANN system was found to be successful in estimation of pattern measures of garments. The prediction of dimensional properties produced by the neural network model proved to be highly reliable ( $R^2 > 0.99$ ).*

**Key words:** cloth dimensional change, knitted fabric, relaxation, artificial neural networks.

## Introduction

Since relaxation operations on textile products during garment production are laborious and time-consuming processes which require abundant space, this problem causes difficulties for manufacturers and result in quality issues which elevate customer dissatisfactions. In textile finishing facilities, fabrics are batched appropriately for garment manufacturing purposes, but these operations result in dimensional changes in fabrics under stress. Although fabrics undergo finishing operations so that they could be delivered to manufacturers in the range of shrinking values desired, garment manufacturers still complain about dimensional change issue, and they remark that they need to take additional operations to resolve these problems. Especially this problem is encountered more frequently with woven fabrics containing elastane. It was observed that problems encountered due to dimensional changes in woven fabrics containing elastane constituted almost 60% of all errors, and thus this could be considered as a prominent issue still prevailing before manufacturers to be resolved. Current researches in the literature stated that dimensional changes experienced in fabrics during garment manufacturing is considered as a serious problem [1]. As a solution the dimensional change issue, estimation of dimensional change before production is considered, which could occur during the production process and be helpful in the

prevention of the afore-mentioned negative circumstances.

In the last twenty years, intelligent machines that use artificial neural systems have been developed to improve the quality of our lives further. As is known, people and animals are much better and faster at recognizing images than most advanced computers. Although computers outperform both biological and artificial neural systems in tasks based on precise and fast arithmetic operations, artificial neural systems represent a promising new generation of information processing networks. Advances have been made in applying such systems to problems found intractable or difficult for traditional computation [2, 19].

The purpose of the present study was to minimise additional processes incurred by garment manufacturers and to offer them a solution ensuring them complete production in the earliest period within specified dimensions, to deliver the product on time and with the quality expected, which would enable manufacturers to gain competitive strength. The methodological approach developed through artificial neural networks could be considered as a frontier study in the garment manufacturing industry, especially for facilities producing garments with woven fabrics displaying significant tension problems, in terms of advantages such as the shortening relaxation time and prevention of garment dimensional changes.

Utilisation of artificial neural networks (ANN) in the textile industry has increased recently. ANN Systems have been successfully utilised in the classification of errors in textile processes, estimation of yarn quality parameters, classification of knitted and woven fabrics, estimation of fabric attitude characteristics, estimation of garment comfort, air permeability of knitted and woven fabrics, and estimation of fabric drape and mechanical properties of fabrics like static tear strength [3-15]. An artificial neural network has also been utilised to estimate the unshrinkability of single jersey fabrics. The regression method and ANN systems were used in the estimation process individually; however, it was emphasised that the estimation strength of the ANN model was superior [16]. The ANN method was utilised in estimation of the dimensional characteristics of rib fabrics as well. In afore-mentioned study, it was reported that the estimation strength of the model established on an ANN was significant for rib fabrics [17-18]. In a study conducted to estimate dimensional properties in garment manufacturing, an ANN and hybrid system called the immune eco-evolutionary algorithm (ICEA) were used jointly for beginners so as to develop a system for pattern design. In order to estimate appropriate and optimal dimensions of garments through the ANN – ICEA model, a study was conducted on 450 garments. Three pattern sizes were taken into consideration: W – waist width, H – hip line

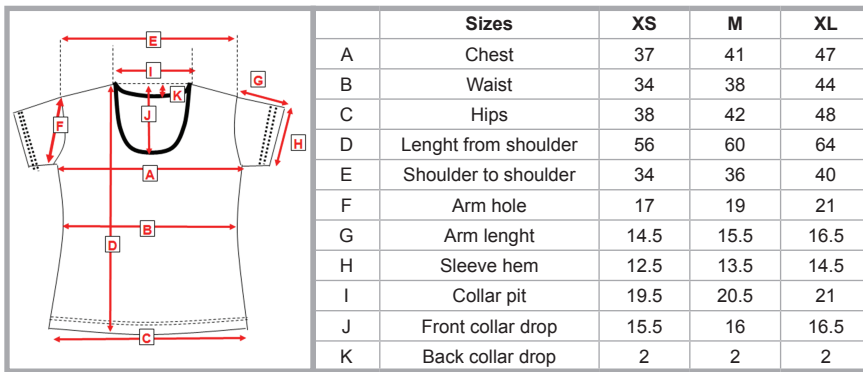

Figure 1. T-shirt pattern and dimensional properties.

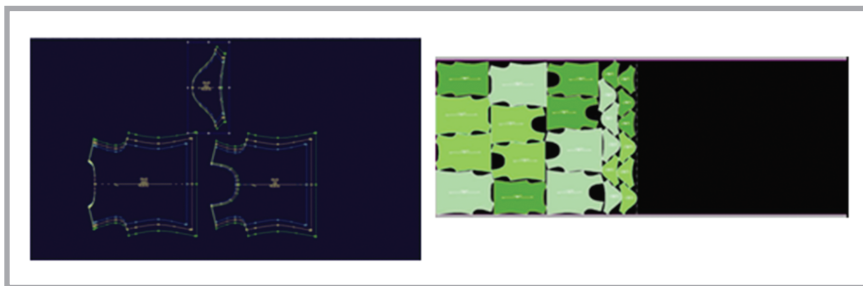

Figure 2. Serialized T-shirt patterns and cloth spreading plan.

and L- body length. Values were 66 cm, 87 cm and 95 cm, respectively. 6 body sizes were selected as an auxiliary body size (H- hip line, L- pant length, INA- total inside seam angle, UBW- up of back waist, FC- groin thickness, BH- hip line). Whereas the entry values used in the study were these six measurements mentioned, the exit parameter is the fit pattern size. As a result of the study, the estimation and optimisation strength of individual algorithms developed for fit-garments regarding the pattern size of the hybrid system were compared [19]. In all studies conducted based on ANN systems, it was observed that artificial neural networks yielded successful results in estimation. In the present study, it was aimed to bring about a solution for estimation of the garment pattern size and dimen-

sional change problems experienced in garment manufacturing facilities, which cause a waste of time and quality-related problems.

### Material and method

In this study single jersey and interlock fabrics were produced in Deniz Textile, located in Denizli, Turkey. Size changes of the fabrics were estimated using Artificial Neural Networks (ANN). To that end, for each of the two fabric groups, made up of different materials in three different densities through two different knitting techniques of single jersey and interlock, either containing elastane or not, a total of 72 different types of fabric were manufactured. Knitted fabrics were processed through finishing operations in

Table 1. Fabric properties.

Yarn No	Type of yarn	Type of fabric	Knitting tightness	Fabric code
20 tex	1. 100% Cotton	Single, jersey	Intense, medium, loose	S
	2. 50% Cotton – 50% Viscose	Single, jersey / lycra (95/5)	Intense, medium, loose	LS
	3. 100% Viscose			
	4. 50% Cotton – 50% Polyester	Interlock	Intense, medium, loose	INT
5. 100% Polyester	Interlock / lycra (95/5)	Intense, medium, loose	LINT	
6. 50% Polyester – 50% Viscose				

Table 2. Cloth spreading plan for T-shirt pattern for all fabrics.

Size	Assortment	Planned minimum number of layers	Length of cloth spreading, cm	Unit length, cm	Total number of cut
XS, M, XL	2:2:2	3 layers	374	59	6+6+6=18 pcs.

a controlled environment. Following the garment manufacturing process, dimensions of the ultimate product (T-shirt) were taken and recorded individually. According to Table 1, the stitch length (100 needle /cm) of single jersey fabrics were 27-intense, 29-medium & 32-loose fabrics, and those of interlock fabrics were 32-intense, 34-medium & 36-loose fabrics.

### Garment pattern and manufacturing processes

A lady's short sleeve T-shirt pattern was determined for the garment. This T-shirt pattern has a circular neck with 0.5 cm binding tape made up of its own fabric, short sleeves, and the hem width and armpit are stitched with 1 cm hemming folding. Dimensional properties and a technical drawing are exhibited in Figure 1.

### Preparation of patterns and cloth spreading processes

For the model type selected, an M-size basic pattern was prepared by means of the computer-aided Gerber®, USA pattern design system in a digital environment. A serialization operation was conducted for XS, M & XL sizes by taking the basic body into consideration, and the cloth spreading plan was studied in a 2:2:2 assortment form (Figure 2). The purpose of selection of XS, M and XL sizes is the necessity of keeping the proportions of vaulting amounts at higher values for evaluation purposes.

The cloth spreading length was adjusted for each fabric in a way that each layer has an assortment for XS, M and XL sizes of 2:2:2, respectively. Table 2 exhibits the cloth spreading plan for the T-shirt pattern.

### Spreading, cutting and sewing processes

Cloth spreading was completed on a semi-automatic spreading machine. In order to ensure the optimum setting for spreading tension, all spreading processes were conducted by workers rigorously assigned to only this task. A sewing plan was prepared on the basis of an operation list determined for the t-shirt pattern, machine, apparatus and equipment for each operation, personnel details and on the organisation of an the appropriate sewing line. Sewing processes was conducted according to the sewing plan in Table 3, the operation list and specified machineries.

## Ironing

After the sewing processes, T-shirts were first passed through dimension control before ironing operation; then, in order to determine the effect of ironing operation on dimensional changes in all fabric types, they were ironed by means of an industrial hand iron, and their sizes were recorded.

## Taking measurements of T-shirt parameters

Parameters of the t-shirts after the sewing process are exhibited in **Table 4**.

The measurement results collected are exhibited as (-), 0, (+) depends on whether the measurement result was greater, equal or less than the measurement desired. **Table 5** exhibits measurement control points for the T-shirt and a relevant tolerance table with respect to sizes. The measurement tolerance table was prepared subject to 2% error for all measurement parameters on average, and rounded in centimeters. All measurements were taken according to the parameters in **Table 4** in dependence on the tolerance values in **Table 5**, and the results were recorded.

## Artificial neural networks and structure

An ANN is an information-processing system that has certain performance characteristics in common with biological neural networks. Work on artificial neural networks, commonly referred to as “neural networks,” has been motivated right from its inception by the recognition that the human brain computes in an entirely different way from a conventional digital computer. ANNs are computer systems developed to use talents such as deriving, creating and exploring new information through learning, one of the main characteristics of the human brain. The performance of these skills by means of conventional programming methods is rather difficult or not possible at all. According to another definition, ANNs are computer systems which could learn events and determine how to react against incidents which occur in its periphery by using examples executed by humans. Additionally they could be utilised in various fields such as learning, association, classification, generalisation, quality determination and optimisation, similar to the functional characteristics of the human brain. They could build up their individual experiences and then make sim-

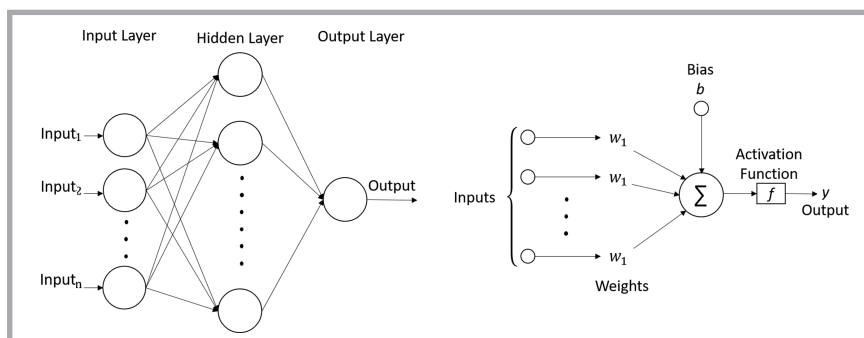

Figure 3. Artificial neural network structure.

ilar decisions in similar subjects. Technically the most essential task of ANNs is to estimate a specific output dataset corresponding to a certain given dataset. In order to accomplish this, the network is required to be equipped with a talent that could make a generalisation through training with sample cases relevant to the incident. By means of this generalisation, output data sets which correspond to certain incidents could be determined.

A neural network is characterised by its pattern of connections between neurons (called its architecture), its method of determining the weights on the connections (called its training, or learning algorithm), and its activation function [20-21]. Like neuron cells within the human neural system, artificial neural networks have artificial neural cells at the input layer, hidden layer and output layer, as were illustrated in **Figure 3**.

Table 3. T-shirt pattern sewing work flow.

Operation No	Operation	Machinery type
1	Attachment of shoulders (right + left)	3-yarn overlock
2	Sewing binding stripe	Cover stitch machine
3	Attachment of arms to the body (right + left)	3-yarn overlock
4	Bonding side stitches (starting from arm end) (right + left)	3-yarn overlock
5	Sewing arm hem	Cover stitch machine
6	Sewing hipsend	Cover stitch machine

Table 4. Garment measurement parameters.

Parameter	Number of classes	Explanation
Fabric type	72	
Size type	3	XS, M, XL sizes
Ironing	2	1. Before ironing 2. After ironing
T-shirt measurement point	11	
Minimum number of T-shirts to be measured	5	

Table 5. Measurement tolerance table.

Measurement point	Sizes		
	Tolerances (- / + cm)		
	XS	M	XL
Chest	0/+0.5	-0.5/+0.5	-0.5/+1.0
Waist	0/+0.5	-0.5/+0.5	-0.5/+1.0
Hips	0/+0.5	-0.5/+0.5	-0.5/+1.0
Length from shoulder	0/+0.5	-0.5/+0.5	-0.5/+1.0
Shoulder to shoulder	0/+0.5	0/+0.5	0/+0.5
Arm hole	0/+0.5	0/+0.5	0/+0.5
Arm length	0/+0.5	0/+0.5	0/+0.5
Sleeve hem	0/+0.5	0/+0.5	0/+0.5
Collar pit	0/+0.5	0/+0.5	0/+0.5
Front collar drop	0/+0.3	0/+0.4	0/+0.5
Back collar drop	0/+0.3	0/+0.4	0/+0.5

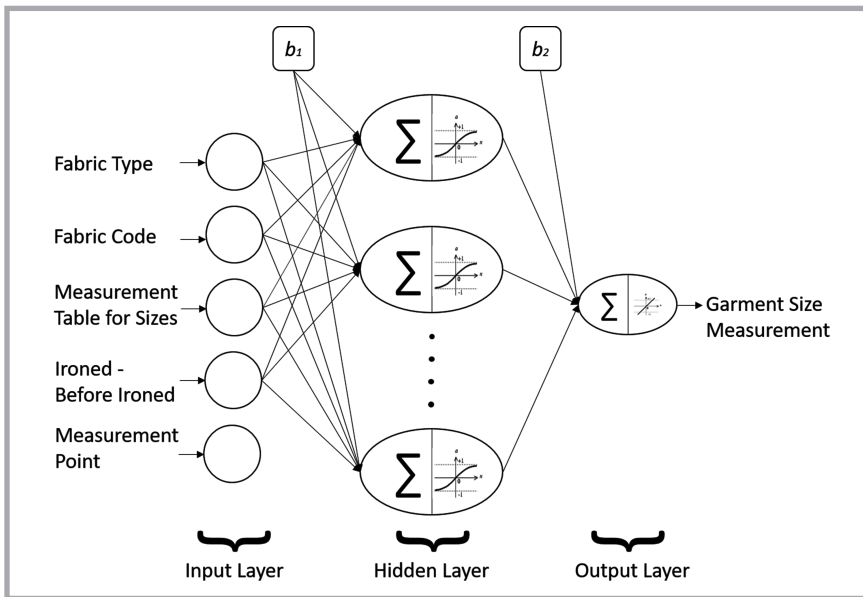

**Figure 4.** Artificial neural network for garment pattern structured for prediction of measurements.

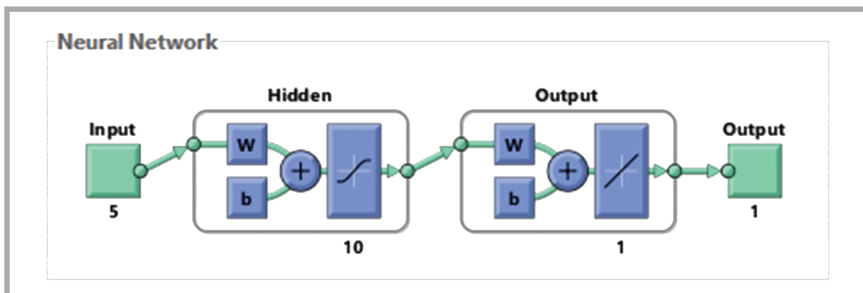

**Figure 5.** Diagram of artificial neural network structured for measurement of garment dimensions.

In the present study, utilising a MATLAB® Neural Network Toolbox, Feed Forward-Back propagation network ANN models were structured with three or four layers, including an input layer, one or two hidden layer(s) and an output layer.

Whereas the initial value was assigned randomly in the structured ANN pattern, changes in weights were conducted on an on-line basis. In other words, using

error that is calculated with difference in target and prediction value. Whereas the sigmoid activation function is used as an activation function, the network continues learning until reaching a certain number of iterations (epoch) after the ANN commenced training with determined network parameters (the number of iterations was determined as 1.000 for the present study). The activation function utilised in this study was the sigmoid

function, which represents the most appropriate one for problems in which sensitive evaluations would be made since it is suitable for derivative operations.

Since verbal values are required to be entered as relevant numerical data, all entries were coded. While “Fabric Type” was coded as 1, 2, 3, 4 (S, LS, INT, LINT), “Fabric Codes” were reflected in numeric expressions in the range of “1, 2, 3, ..., 18” (S.1, S.2,S.3,..., S.18). Since the parameter table for XS, M and XL sizes displays the difference with respect to the 11 specific measurement points of the T-shirt, their regular corresponding values were also entered. For instance, the chest parameter of the XS size is 37 cm. Parameters in the measurement table for the T-shirt were entered as real measured values, such as (-0.5), (1), (0) and (0.5), because they were actually measured numerically. For example, regarding the XS size, if a chest parameter of 37 cm exhibited -0.5 cm shrinkage, its parameter was entered as 36.5. All measurement points such as chest, waist, hips etc. were replaced with numerical values of 1, 2, 3, 4, 5, 6, 7, 8, 9, 10 and 11, respectively. In order to determine the ironing effect, before ironing and after ironing periods were conferred with 1 and 2 codes, respectively. **Figure 4** displays schematically the ANN pattern utilised in the present study.

The network pattern was structured with 5 inputs and 1 output, as illustrated in **Figure 5**. In this illustration, the number of hidden layers seems to be only one. However, networks with 2 hidden layers were also structured in the study. There are 10 neurons in the hidden layer of the network displayed in **Figure 5**. In this study the maximum correct prediction was obtained with 10 neurons in the hidden layer as a result of all experiments. In total a data set with 5 entries including 4.752 sample data was utilized. Seventy percent of entry vectors of the network, in other words, 3.326 data, were used in the training period, with 498 units (15%) for “Validation” and the remaining 498 units (15%) for testing. Validation data were employed during training so as to enhance the performance of the artificial neural network. The network completed the learning process after the 240-epoch based on the mean square error (MSE) method.

The MSE value was calculated by MATLAB according to **Equation (1)** below:

**Table 6.** Parameters of the structured artificial neural network.

Network parameters	
Number of Input Parameters	5
Number of Hidden Layers	1 or 2
Number of Neurons in Hidden Layer	From 1 to 50
Learning Rate	0.001
Momentum Coefficient	0.8
Number of Iterations	1000
Number of Output Parameters	1
Number of Neurons of the Most Successful Network	10
Number of Iterations of the Most Successful Network	246
MSE Value of the Most Successful Network	0.61
R <sup>2</sup> Value of the Most Successful Network	0.99

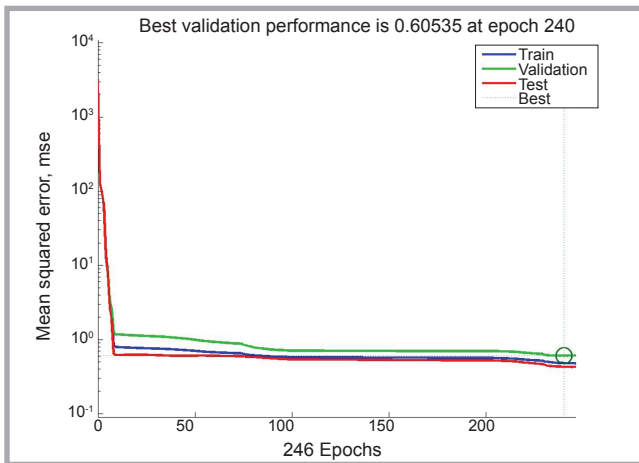

**Figure 6.** Network training yielding the best result for measurement of a garment parameter.

$$MSE = \frac{\sum (y_i - \hat{y}_i)^2}{T} \quad (1)$$

Where:

$y_i$  – measured value,  $\hat{y}_i$  – estimated value,  $T$  – number of estimation.

In the light of the information given above, performances of the structured networks were investigated for different values of the learning rule, momentum coefficient, the number of hidden layers and the number of nodes in the hidden layer in order to determine the most appropriate ANN performance values. Accordingly the number of hidden layers and cells in the hidden layers as well as the learning rate and momentum coefficients in the study were determined based on data frequently encountered in the relevant literature. Whereas the learning rate and momentum coefficient was selected as 0.001 and 0.8, respectively, the hidden layer was selected as 1 and 2. In the structured model, the number of neurons of the hidden layer was tested in the range from 1 to 50. **Table 6** exhibits parameters of the structured ANN.

**Table 7** exhibits both experimental measurement results of randomly selected t-shirt parameters and relevant estimations of the ANN model.

During the training of the structured network, weights were determined subject to the training set, and these determined weights were transferred to the validation set in the meantime. As this process continues, network training was finalised at the point where the MSE value of the validation set started to increase so that excessive learning risk – memorisation – is eliminated. Weights determined at the point where the network training was finalised, that is at the end of the 240 iterations, the best and ultimate weight was determined for the network.

## Results and discussion

Based on the values above, after the training process of the network, the artificial neural network is expected to estimate the measurement of any parameter

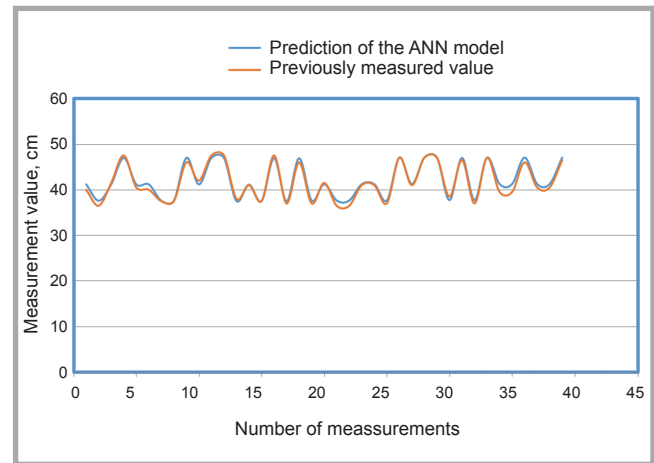

**Figure 7.** Comparison of real values and estimated values given by the ANN model.

exhibited in the dimension parameter table regarding any fabric and body size of a t-shirt for both before-iron and after-iron conditions.

In order to test the consistency of the results obtained, the relevant performance (criterion for success or accurate estimation) value was measured. Thus the network was expanded from a structure with a 1-noded hidden layer to a 50-noded hidden layer value so that the weights of the network pattern which yielded the highest precision value could be obtained.

Upon completion of the training stage of the ANN model for the parameters determined, by taking the correlation coefficient (R) and mean square (MSE) parameters into consideration, the estimation performance of the network was evaluated. If an acceptable MSE value is obtained at the end of the network training, the structured ANN was tested. During the testing stage, estimation results obtained by entering data which have not

**Table 7.** Experimental measurement results of garment dimensional parameters and their comparison with relevant estimations of the ANN model.

Fabric type (S, LS, INT, LINT)	Fabric code (1,2,3,... 18)	XS, M, XL size table values	Before ironing (1), after ironing (2)	Measurement area (chest, waist, hips, ...)	Prediction of ANN model	Expected (previously measured value)	Error	Error, %
1	1	41	1	1	41.15	40.00	1.15	2.87
1	3	37	1	1	37.55	36.50	1.05	2.88
1	4	41	1	1	41.15	41.50	-0.35	0.84
1	4	47	1	1	46.96	47.50	-0.54	1.14
1	5	41	1	1	41.15	40.50	0.65	1.61
1	6	41	1	1	41.15	40.00	1.15	2.87
1	7	37	1	1	37.53	37.50	0.03	0.09
1	7	37	1	1	37.53	37.50	0.03	0.09
1	7	47	1	1	46.96	46.00	0.96	2.08
1	8	41	1	1	41.13	42.00	-0.87	2.06

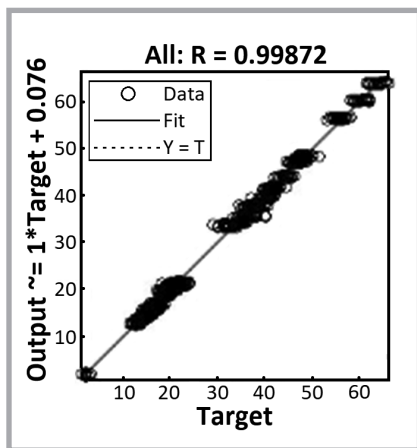

Figure 8. Network correlation coefficient.

been introduced to the network before and concealed to test the network into the network model were compared with the real data.

The network model obtained at the end of 244 iterations was determined as the most successful network model since it yielded the highest correlation coefficient ( $R^2 = 0.99872$ ). As a result of the repeated iterations, the error yielded by the network decreased progressively, while the number of iterations increased. The lowest MSE was determined as 0.60535 at the end of the training process of the network (Figure 6).

Figure 7 exhibits a comparison of real values and estimation values of 39 measurement points randomly selected. While the x-axis indicates measurement results (cm), the y-axis indicates the number of measurement points.

As an example of the comparison process, concerning a t-shirt with fabric characterised as S “Fabric Type” and 2 “Fabric Code” (referred as S.2) in XS size (measurement desired: 41 cm), before-ironing (1), the dimension of the waist (1) area was estimated as 41.15 by the network model. The real value measured experimentally was 40 cm. Accordingly the relevant error was determined as 2.87%. In other words, the structured ANN model could estimate the relevant chest dimension parameter with 97.13% accuracy.

When all results are taken into consideration regarding the estimation performance of the network model, the correlation between the real and estimated values was determined, as revealed by the high correlation coefficient of  $R = 0.99872$  in Figure 8.

Based on the regression coefficient in Figure 8 ( $R = 0.99872$ ), it could be observed that the data have a linear structure, which suggests that the estimation strength of the structured network was rather high.

## Conclusions

Feed forward-back propagation artificial neural network pattern models with the momentum learning rule and sigmoid transfer function were structured to estimate dimensional changes. As a result of the study, it could be concluded that the ANN could successfully estimate dimensional changes in fabrics and accordingly estimate dimensional changes in a garment.

Although fabrics are delivered to garment manufacturers from finishing facilities with the values desired, tensions experienced by fabric during the cloth take-up process and cloth spreading process during garment manufacturing increase total internal tensions in the fabric. When the necessity to spread and rest fabrics brought into a garment manufacturing facility and associated labor, time, energy costs are considered, especially for fabrics with great dimensional change potential, estimation methods (artificial neural networks) would eliminate additional operations to resolve the tension problem, and thus productivity would be increased.

## References

1. Kalkanci M, Kurumer G. Investigation of Dimensional Changes During Garment Production and Suggestions for Solutions. *Fibres and Textiles in Eastern Europe* 2015; 23, 3(111): 8-13.
2. Çetinel H, Öztürk H, Çelik E, Karlık B. *Wear* 261, 2006; 1064-1068.
3. Matusiak M. Application of Artificial Neural Networks to Predict the Air Permeability of Woven Fabrics. *Fibres and Textiles in Eastern Europe* 2015; 23, 1(109): 41-48.
4. Bhattacharjee D, Kothari VK. A Neural Network System for Prediction of Thermal Resistance of Textile Fabrics. *Textile Research Journal* 2007; 77, 4-12.
5. Hui CL, Lau TW, Ng SF, Chan KCC. Neural Network Prediction of Human Psychological Perceptions of Fabric Hand. *Textile Research Journal* 2004; 74, 375-383.
6. Park SW, Hwang YG, Kang BC, Yeo SW. Applying Fuzzy Logic and Neural Networks to Total Hand Evaluation of Knitted Fabrics. *Textile Research Journal* 2000; 70, 675-681.
7. Majumdar A. Modelling of Thermal Conductivity of Knitted Fabrics Made of Cot-

ton-Bamboo Yarns Using Artificial Neural Network. *The Journal of the Textile Institute* 2011; 102(9), 752-762.

8. Wong ASW, Li Y, Yeung PKW, Lee PWH. Neural Network Predictions of Human Psychological Perceptions of Clothing Sensory Comfort. *Textile Research Journal*, 2003; 73, 31-37.
9. Kumar V, Sampath VR. Investigation on the Physical and Dimensional Properties of Single Jersey Fabrics made from Cotton Sheath-Elastomeric Core Spun. *Fibres and Textiles in Eastern Europe*; 2013; 21, 3(99): 73-75.
10. Farooq A. Predicting the Dynamic Cohesion in Drafted Slivers at Draw Frame Using Artificial Neural Networks. *Tekstil ve Konfeksiyon*, 2014; 24(3).
11. Murrels CM, Tao XM, Xu BG, ve Cheng KPS. An artificial neural network model for the Prediction of Spirality fully Relaxed Single Jersey Fabrics. *Textile Research Journal* 2009; 79(3), 227-234.
12. Jianda C, Xiaojun G, Lianfu Y. Research On BP Neural Network Applied to Predict Cotton Fabric Handle. *Proceedings of The Textile Institute 83 rd World Conference 2004*, 1265-1268.
13. Hui C-L, NG S-F, (). A New Approach for Prediction of Sewing Performance of Fabrics in Apparel Manufacturing Using Artificial Neural Networks. *The Journal of Textile Institute* 2005; 96, 6, 401-405.
14. Witkowska B, Koszłaga J, Frydrych I. Modelling the Mechanical Properties of Cotton Fabrics Using Multilayer Perceptron Neural Network. *Archtex'2005 Conference, Kraków*, 2005, pp. 61-67.
15. Witkowska B, Frydrych I A. Comparative Analysis of Modelling the Static Tear Strength by the Neural Networks and Statistical Model. AUTEX conference 2007, Tampere, Finland.
16. Bhattacharya S. Application of Artificial Neural Networks for Prediction of Shrinkage of Single Jersey Cotton Knit Fabrics. *6th International Conference-TEXSCI 2007*, 237-239, Czech Republic-Liberec.
17. Saravana KT, Sampath V. An Artificial Neural Network System for Prediction of Dimensional Properties of Weft Knitted Rib Fabric. *Journal of the Textile Association* 2011; 71(5): 247-250.
18. Saravana KT, Sampath VR. Prediction of Dimensional Properties of Weft Knitted Cardigan Fabric by Artificial Neural Network System. *Journal of Industrial Textiles* 2013, 42(4) 446-458.
19. Zhi-Hua Hu. A hybrid System Based on Neural Network and Immune-co-evolutionary Algorithm for Garment Pattern Design Optimization. *Journal of Computers* 2009; 4, 11.
20. Simon, H. *Neural Networks*, Macmillan, New Jersey, 1994.
21. Fausett, L. *Fundamentals of Neural Networks*, Prentice Hall, New Jersey, 1994.

Received 13.06.2016 Reviewed 28.04.2017