

# Assesing the Wear of Spindle Neck Coating Made of AlCu4Mg1 Alloy of Ring Spinning Spindles with an Antiballoon Crown

## Abstract

*This paper presents the results of observation and measurements of the wear of a spindle-neck coating made of the aluminium alloy AlCu4Mg1 of an anti-balloon crown of a PG-7A ring-spinning frame. Evaluation of the wear of the spindle neck was carried out in industrial conditions while manufacturing two types of yarn blends: 20 ÷ 30% of polyester fibres + 80 ÷ 70% wool, as well as 90% wool + 10% polyamide fibres, or 100% wool fibres. Measurements of chosen parameters of the 3D surface geometric structure (SGS) as well as the surface topography of the spindle neck layer before and after the operation were performed. In addition to the surface microphotography, the distributions of elementary chemical elements in different places of the wear, which have on the shape of a helical groove, are given. Analysis of the surface microphotography and topography confirmed that the external surface of the surface layer of neck coating undergoes non-uniform wear. Different contents of the elementary chemical elements at different points of contact with the yarn as well as a detailed analysis of the wear surface in the helical groove imply that the wear of the spindle neck coating made of the aluminium alloy AlCu4Mg1 is basically caused by abrasion.*

**Key words:** ring spinning frame, anti-balloon spindle, spindle crown, operation wear.

## Introduction

Some parts of the ring-spinning frames devoted for anti-balloon spinning come into direct contact with the yarn (the stream of fibres). These are the yarn guides: the anti-balloon crowns, the neck of the spindles coatings, etc. The operating surfaces of these parts should fulfil at least three conditions:

- they should have a low coefficient of friction when in contact with the yarn, which mainly depends on the stereometric structure of this surface (SGS 3D) shaped by the manufacture method;
- they must not generate static charges and should not load the yarn electrostatically;
- they must be sufficiently resistant to wear and any accidental impacts.

The textile machinery manufacturer BEFAMA (Poland) has recently produced ring-spinning frames with an anti-balloon crowns and spindle neck coatings made of the aluminium alloy AlCu4Mg1 in super-saturation and ageing state. During the spinning process, the yarn moves at a speed of about 35 m/s with a tension varying from 0.06 to 0.30 N. This causes more or less intensive wear of the contact nodes of ring-spinning frames. On ring-spinning frames both the yarn guides and the spindle-neck coating, which are manufactured at the tolerance of IT10 with the surface roughness  $R_a \leq 0.32 \mu\text{m}$ , are particularly vulnerable to wear. The surface of the neck coating is currently manufactured by rough

turning, forming and finishing. The two cuts are ground with an abrasive cloth of grain, one of magnitude 80 and another of 150, and then polished with de-sludged paper.

Several year's observation of spindle operations in industrial production conditions have confirmed that the durability of the neck coating of spindles is far lower than the other elements of the complete spindle. It is precisely 2.5 times lower than the durability of the bearing insert, made by SKF (Germany) with a lifetime of 6 years for 3 working shifts, as determined by the manufacturer. This was particularly noticeable while manufacturing yarns that are a blend of 30 ÷ 55% polyester fibres and 70 ÷ 45% wool fibres. Most manufacturers of ring-spinning frames for carded yarn and half-worsted yarn, as well as the manufacturers of spindles with an anti-balloon crown, solve this problem by changing their designs: this involves the correct shaping of the crown and spindle-neck coating, i.e. by maintaining the correct dimensional proportions of the crown and neck coating. Another method consists in the application of two-part coatings with a neck made of quenched and tempered steel or sintered ceramics.

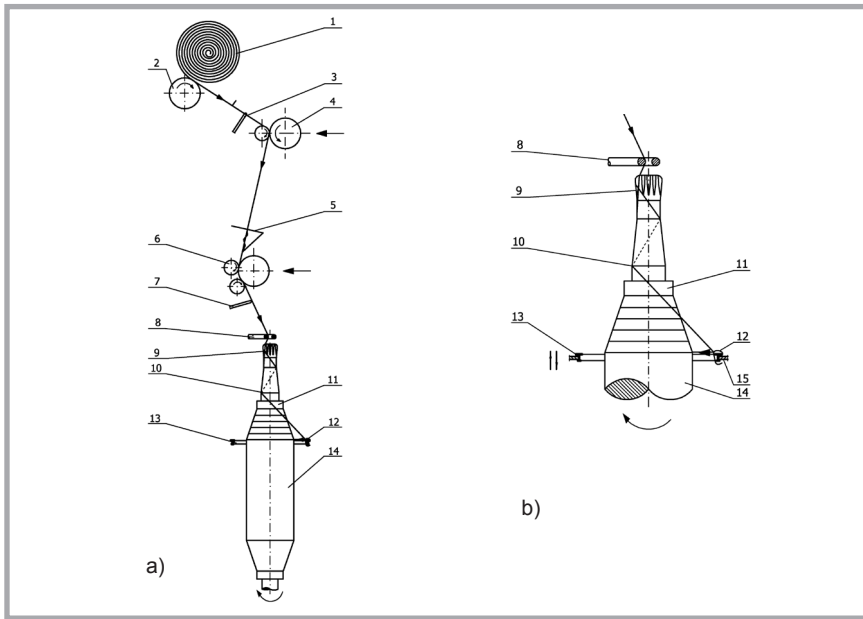
Variations of spindle dimensions can give undesirable results. E.g. the plant BEFAMA has decided that there is a possibility better operating ring-spinning frames by decreasing the angle of the neck coating inclination (thus minimalising the differ-

ence in crown diameters from the side of the guide and neck coating). It has allowed the removal of the yarn that is torn off and wound onto the spindle-neck coating without cutting. The design changes of the crown approaches the guide to the crown head to allow the moving yarn to enter into the grooves (notches). The effect was that there was an increase in the angle of contact of the neck coating with the yarn. It caused that the yarn minimalised the balloon generated during the rotation of the spindle: however, the phenomena of the accelerated wear of the spindle-neck coating occurred.

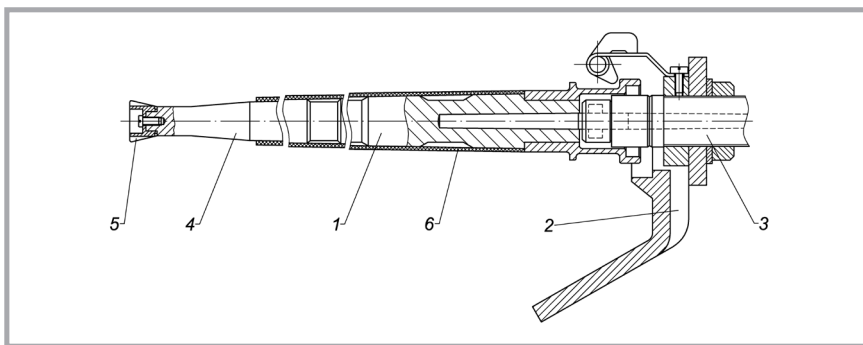
The aim of this work was the determination of the durability of spindle neck coating during the processing the raw materials, such as 20 ÷ 30% of polyester fibres + 80 ÷ 70% wool, 90% wool + 10% polyamid fibres, and 100% wool fibres. However, an effort to explain the reasons for the wear of the spindle neck coating during the yarn processing was made.

## Method of evaluating the wear of spindle-neck coating with an anti-balloon crown

The system of wool-carded yarn applies to ring spinning frames that have different solutions for feeding devices, a different design of tensioning apparatus, and to those which have spindles with an anti-balloon crown. The roving that is received from the belt separator is directed to the stretched apparatus, which



**Figure 1.** Technological lay-out of the PG-7A ring spinning frame: a) the run of fibre stream from the unrolling shaft of the roving to the lap of the yarn; b) the run of fibre stream from the guide to the lap of the yarn; 1 – roving, 2 – unrolling shaft, 3 – roving guide, 4 – feed rollers, 5 – false twist spiral, 6 – delivery rollers, 7 – suction cleaner, 8 – yarn guide, 9 – crown, 10 – spinning spindle, 11 – bobbin, 12 – traveller, 13 – ring, 14 – lap of yarn, 15 – ring frame.



**Figure 2.** The spindle with the collapsed balloon crown of the PG-7A ring spinning frame: 1 – spindle feather, 2 – brake, 3 – spindle bearing unit, 4 – spindle neck made of the aluminum alloy AlCu4Mg1, 5 – spindle crown, 6 – bobbin.

**Table 1.** Types of yarn used on the PG-7A ring spinning machine, their characteristics and time period percentage of manufacturing.

Type of raw material		Yarn linear density, tex	Number of yarn twists per 1 meter, 1/m	Number of spindle revolutions, r.p.m.	Percentage of the processing time, %
Ring spinning frame PG-7A (1)	Polyester 30% + wool 70%	100; 125	390; 360	9500+10000	77.6
	Polyester 20% + wool 80%	150	280	8500	22.4
Ring spinning frame PG-7A (2)	Polyamid 10% + wool 90%	125	310	8000	94.0
	Wool 100%	110	360	7500	6.0

is a set of two-pair rollers. This consists of feed rollers (4), a false twist spiral (5) and output rollers (6) (**Figure 1**). The inner diameter of the spiral coils is smaller than the diameter of the stretched stream

of fibres, and its transport through the spiral faces some resistance. In the area of contact with the coils of spiral, the fibres undergo compaction, and the stream of fibres rotates around its own axis. Af-

ter passage over the suction cleaner (7), the stream of fibres goes through yarn guide (8) and the groove in crown (5) of spinning spindle (10). The traveller (12) - ring (13) system forms the twist of the fibre stream. As a result of the twist, the fibre stream is transformed into yarn that is wound in the form of yarn packing (14) on bobbin (11). Spindle (10) and bobbin (11) make a rotary motion, and traveller (12) rotates on ring (13) around the axis of spindle (10). However, the to-and-fro motion in the vertical direction is made by ring frame (15) and yarn guide (8) [1].

We investigated the wear of the neck coating of a spindle with an anti-balloon crown upon contact with yarn by means of the metric method [2, 4], on ring spinning frames in production conditions. The complete spindle with the collapse balloon crown of the PG-7A ring spinning machine is shown in **Figure 2**.

We observed two series of spinning spindles of 160 pieces per series each, with an anti-balloon crown, which were installed on two PG-7A ring spinning frames. The wear measurements of the neck coating of the spindle during the process of spinning the blend yarn, which are described in **Table 1**, were carried out at three-month intervals. We used a specially adapted micrometer with a measuring range from 0 to 25 mm, with an elementary scale interval of 0.001 mm. The wear rate  $\Delta z$  was determined as the maximum difference among 5 measurements of the spindle-neck coating made every 60° at a distance of about 5 mm below the crown. A helical groove depth of  $h_r \geq 0.5$  mm was assumed as the criterion of wear or the exchange of spindle.

The profile and dimensions of the helical groove in a direction perpendicular to the run of yarn were determined on a Profil-Messmaschine "Contracer" instrument (series 218 MITUTOYO).

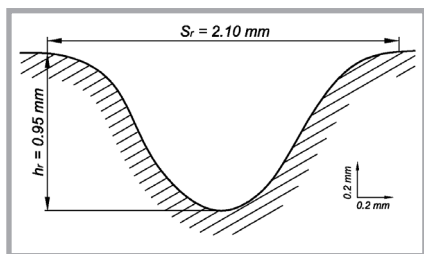
The profilography method was additionally applied to evaluate the wear of the neck coating of the spindles. In the profilography method, which was arranged about 5 mm below the crown, the following parameters of the geometric structure of the 3D surface (before and after the period of using the spindles) were noted: amplitude parameters – the mean arithmetical of the surface ordinates  $S_a$ ; the mean square deviation of the surface  $S_q$ ; the maximum height of the surface peaks  $S_p$ ; the maximum depth of the surface

cavities  $S_v$ ; the maximum height of the surface  $S_s$ ; the parameters of the surface curve of the material part: the depth of the surface core  $S_k$ ; the reduced height of the surface peaks  $S_{pk}$ ; the reduced depth of the surface cavities  $S_{vk}$ ; the load capacity part of the surface peaks  $S_{r1}$ ; the load capacity part of the surface cavities  $S_{r2}$ .

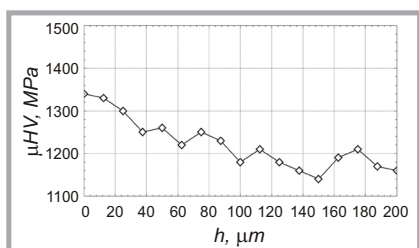
The formulae of the three-dimensional amplitude parameters are given in [5 - 7]. The measurements of selected 3D SGS parameters were made with a Pethometer Concept profilometer from the Mahr company. Photos of the surface topography were taken of size  $2.0 \times 2.0$  mm at distances of  $5 \mu\text{m}$  each.

Microhardness measurements were carried out on skewed specimens positioned at the angle of  $1^\circ 30'$  ( $0.026$  rad), with the use of a microhardness meter from Leitz Wetzlar (Germany) at a load of indenter of  $0.245$  N.

Photos (microphotos) of the spindle neck coating of the ring spinning frames were taken after finishing, turning and grinding with abrasive paper, followed by polishing with de-sludged paper. All this was done after a period of operation with the yarn of 14,000 operating hours, at a distance of about  $5$  mm from the crown. The instrument used was a Neophot 32

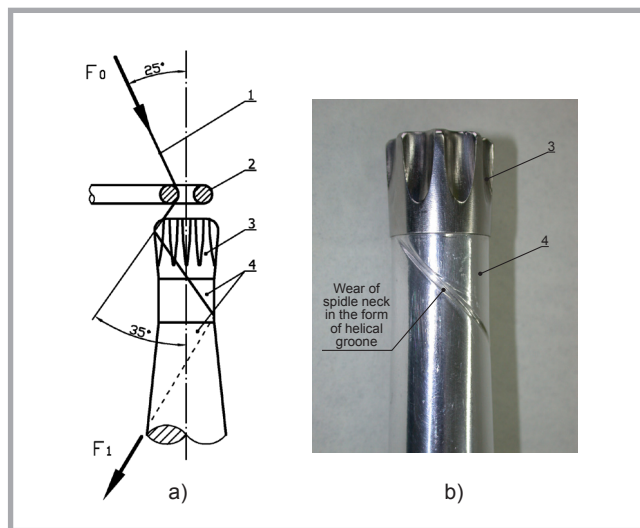


**Figure 4.** Profile and dimensions of a perpendicular cross-section of a groove after 14,000 hours of operation with yarn which was a blend of  $20 \div 30\%$  of polyester fibres +  $80 \div 70\%$  wool fibres.



**Figure 5.** Distribution of micro-hardness across the surface layer of the spinning spindle neck coating made of the alloy  $\text{AlCu4Mg1}$  with a collapsed balloon crown after cloth and abrasive paper grinding (before operation).

**Figure 3.** Spindle neck coating made of the alloy  $\text{AlCu4Mg1}$  with a spindle crown for collapsed balloon spinning: a) the run of yarn from the output rollers on the guide, and afterwards the crown and neck coating; b) wear of the spindle neck coating in the shape of a helical groove after a period of operation of about 14,000 hours. 1 – yarn, 2 – guide, 3 – crown, 4 – spindle neck coating made of the alloy  $\text{AlCu4Mg1}$ .



microscope at a magnification of  $150\times$  and  $400\times$ .

Wear traces on the side surface of the helical groove were observed on a Jeol JSM-5500LV scanning microscope after 14,000 operating hours. However, the investigation of the elements Al, Cu, Fe, Mg, Mn, the Si distribution of the chosen points of the wear on the side surface of the helical groove (matrix and phases) were made with the JCXA 733 X-ray analyser of  $117$  eV resolution.

### Wear of the surface layer of spindle-neck coating made of the alloy $\text{AlCu4Mg1}$ during the spinning process

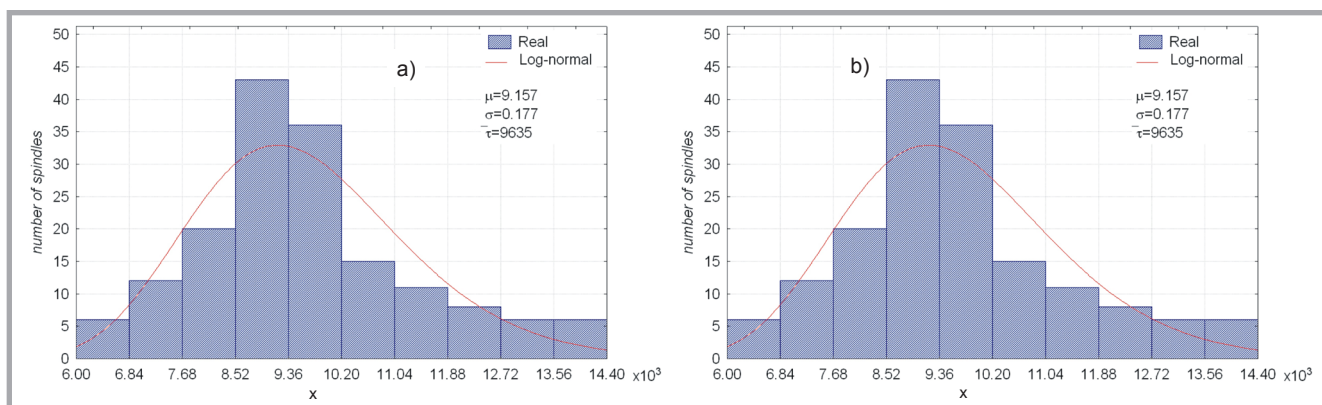
The flow of yarn (stream of fibres) from the output rollers of the stretching apparatus, through the guide, crown and neck coating of the ring spinning spindle is shown in **Figure 3**. After passing through guide (2), one of the notches on the peripheral of crown (3), the yarn while wrapping the neck coating, is pulled through the traveller and finally wound on the bobbin fixed on the spindle (**Figure 1.b**). During the operation of the spindle, the yarn moves at the speed of  $v_w \approx 35$  m/minute (**Figure 3.a**). As a result of local friction, which is caused by the restricted smooth passage ('jumping') from one notch of the crown to the other as well as by the 'holding' of one of the crown teeth, there is excessive wear of the spindle-neck coating. This wear generates helical grooves of  $2$  mm width and about  $1$  mm depth. These grooves make the smooth run of yarn on the neck coating impossible, and consequently induce an increase in the number of yarn rips (**Figure 3.b**).

**Figure 4** shows the profile and dimensions of a perpendicular cross-section of a groove after 14,000 hours of operation with yarn which is a blend of  $20 \div 30\%$  of polyester fibres +  $80 \div 70\%$  wool fibres.

The distribution of microhardness across the surface layer of the spindle neck coating made of the alloy  $\text{AlCu4Mg1}$  before operation is shown in **Figure 5**. A maximum microhardness of  $1340$  MPa occurred on the surface layer. The strengthening depth did not exceed  $40 \mu\text{m}$ .

**Figure 6.a** (see page 36) shows a histogram of the operating time of the spindle neck coating with an anti-balloon crown, operating with yarn that is a blend of  $20 \div 30\%$  of polyester fibres +  $80 \div 70\%$  wool fibres. The one concerning the operation with yarn which is a blend of  $90\%$  wool fibres +  $10\%$  polyester fibres, (or in a short period of time  $100\%$  wool fibres) is presented in **Figure 6.b** (see page 36). Histograms of the operating time of the spindle neck coating were identified by means of the following distributions: normal, power and exponential, Weibull's as well as logarithm-normal. The most convenient matching or the logarithm-normal distribution was obtained (**Figure 6**). The hypothesis of the conformity of empirical and theoretical distribution, for both cases, was verified by means of a chi-square test, at a significance level of  $0.05$ .

According to the histograms, the mean period of the operation  $\tau$  of the spindle neck coating during contact with yarn that is a blend of  $20 \div 30\%$  of polyester fibres +  $80 \div 70\%$  wool fibres, was  $\tau = 9635$  operating hours. However, the contact with the yarn of  $90\%$  wool fibres +  $10\%$  polyester fibres, and in a short period of time



**Figure 6.** Histogram of the wear of the spindle neck coating made of the alloy AlCu4Mg1 with an anti-balloon crown, operating with yarn that is a blend of: a) 20 ÷ 30% of polyester fibres + 80 ÷ 70% wool fibres; b) 90% of wool fibres + 10% polyester fibres, and in a short period of time 100% wool fibres; x - time of work  $\tau$  of the spindle-neckcoating with a collapse balloon crown, in hours.

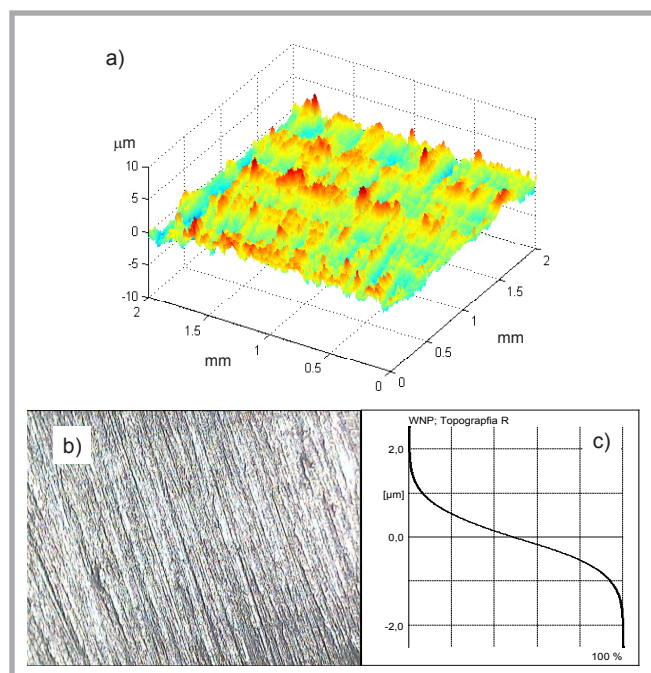
100% wool fibres, was 2.5 times longer and yielded  $\tau = 24343$  operating hours. It can be explained by the lower values of tensioning forces of the yarn, and consequently by lower values of yarn pressure on the neck coating, as well as by lower values of the velocities of the run of yarn: 90% wool fibres + 10% polyamid fibres during the spinning process.

The wear phenomenon of the neck coating is increased by dead particles (grass, bark of trees, straw) present in the fibre stream, as well as by grains of dust that are stuck to the wool fibres [8].

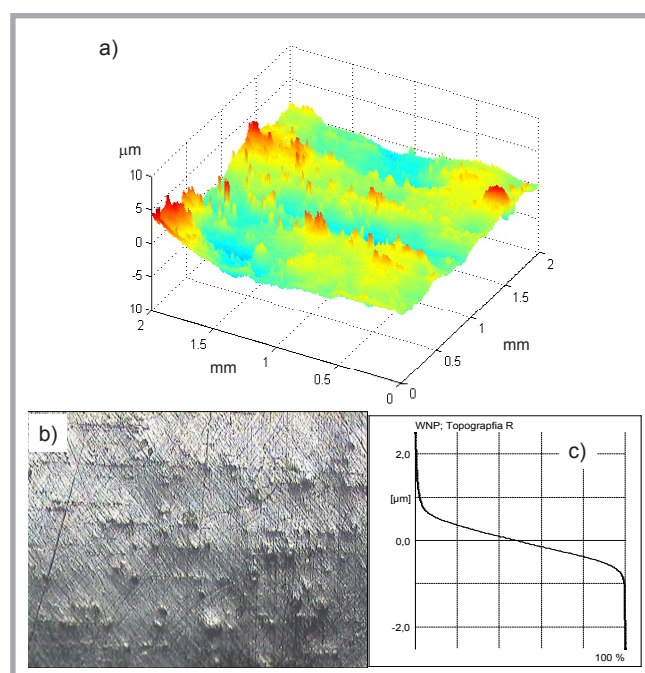
SGP 3D characteristics of the spindle neck coating before and after the operation, including the surface topography, microphotography of surface and the curve of surface material part together with the results of measurements of the chosen 3D surface roughness parameters, are shown in **Figures 7 and 8**.

It can be concluded from the analysis of measurements carried-out that such amplitude parameters as  $S_a$ ,  $S_q$  and  $S_v$  and the parameter showing the reduced depth of cavities  $S_{vk}$  are slightly smaller for the neck surface after a period of operation of about 14,000 hours. It can be

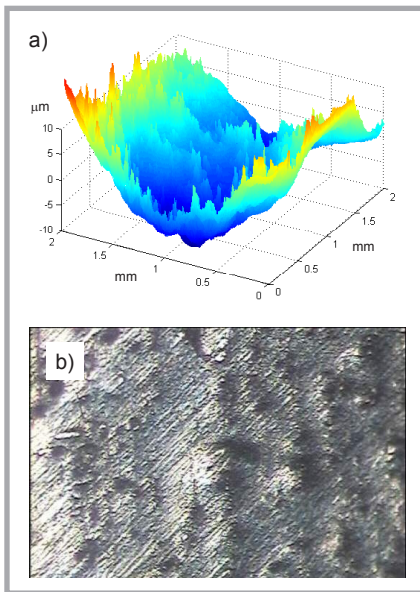
explained by the fact that the yarn moving along the neck coating causes the smoothing of its surface. However, such amplitude parameters as  $S_p$  and  $S_t$  are clearly larger for the neck surface after the operation period. This is caused by local wear in the form of cavities of a helical line profile, which is in accordance with the direction of the run of yarn (**Figure 8.a**) as well as with the considerable sensibility of these parameters for single, accidental heights or cavities. The values of the remaining parameters of the curve of the material part:  $S_k$  and  $S_{pk}$  before and after the operation period are almost identical.



**Figure 7.** Stereometric structure of the neck coating of the spindle with an anti-balloon crown after cloth and abrasive paper grinding operations: a) topography of surface:  $S_a=0.50 \mu\text{m}$ ,  $S_q=0.64 \mu\text{m}$ ,  $S_p=2.74 \mu\text{m}$ ,  $S_v=4.03 \mu\text{m}$ ,  $S_t=6.77 \mu\text{m}$ ,  $S_k=1.97 \mu\text{m}$ ,  $S_{pk}=0.07 \mu\text{m}$ ,  $S_{vk}=0.84 \mu\text{m}$ ,  $S_{mr1}=9.07\%$ ,  $S_{mr2}=88.87\%$ ; b) microphotography of the surface, magnified by 150 $\times$ ; c) curve of the surface material part.



**Figure 8.** Geometric structure of the neck coating of the spindle with an anti-balloon crown after a period of operation of about 84000 hours of contact with the yarn (in the area of surface smoothing): a) topography of the surface:  $S_a=0.38 \mu\text{m}$ ,  $S_q=0.46 \mu\text{m}$ ,  $S_p=4.00 \mu\text{m}$ ,  $S_v=3.80 \mu\text{m}$ ,  $S_t=7.80 \mu\text{m}$ ,  $S_k=2.00 \mu\text{m}$ ,  $S_{pk}=0.08 \mu\text{m}$ ,  $S_{vk}=0.58 \mu\text{m}$ ,  $S_{mr1}=4.15\%$ ,  $S_{mr2}=93.35\%$ ; b) microphotography of the surface, magnified by 150 $\times$ ; c) curve of the surface material part.



**Figure 9.** Topography (a) and micro-photo (b), magnified 400 $\times$ , of the neck coating surface, where it has lost its gloss, i.e. on the edge of the neck wear in the form of a helical groove at a distance of about 2 mm from the crown, which was after operation with yarn of the following blend: 20  $\div$  30% of polyester fibres + 80  $\div$  70% wool fibres; the period of operation being 14000 hours.

**Figure 9** shows the topography and microphoto of the neck coating surface, where it became matt (that has lost its gloss), i.e. on the edge of the neck wear in the form of a helical groove (**Figure 4**), at a distance of about 2 mm from the crown.

A microphoto of the wear surface of the helical groove side wall of the neck coating after a period of operation of about 14,000 hours is shown in **Figure 10**. The photos show the layers arrangement of the matrix and emissions in the shape of light regions of the metallic phase. Deep scars and cavities of a direction in accordance with the yarn motion can also be observed. **Table 2** gives the percentage content of elementary elements Al, Cu, Fe, Mg, Mn and Si in/at the analytical points (in the matrix – point Nos. 1, 2 and 3, as well as in the emissions – point Nos. 4 and 5). An exemplary EDS spectrum of the surface at the point of emission (a phase of type  $AlCuFeMnSi$  – point No. 4) is shown in **Figure 11**. In the  $AlCuFeMnSi$  phase there is about 30% less aluminium 5.3  $\div$  10.3 times less magnesium, but 5.9  $\div$  6.3 times more copper, from 63.3  $\div$  1004 times more ferric, from 4.3  $\div$  18.3 times more manganese, and from 1.08  $\div$  1.33% more silicon with respect to the content of these elementary elements in the matrix. Such a structure

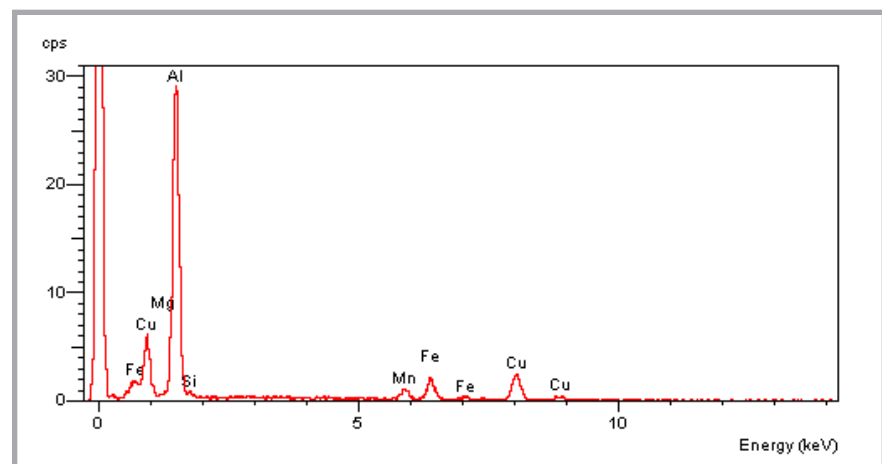
of elementary elements suggests that its hardness is a few times higher than that of the matrix. As a result of this, the process of the wear of the spindle neck coating by the moving yarn starts from the matrix.

**Figure 12** shows a microphoto of the surface that is the wear trace of the side wall of the helical groove at the point of yarn friction, as well as the distribution of the elementary elements Al, Si, Mn, Fe, Cu in the surface layer of the spindle neck coating. Observation of the spindle neck coating with a collapsed balloon crown after a period of operation of about 14,000 and 34,000 operating hours, in the area of yarn contact and magnified by 5 $\times$ , confirms that this surface is smooth and shiny. However, there are negligible dimples on the peripheral along the helical lines that correspond to the direction of the yarn run. A small increase in the time of yarn run of one of the crown teeth, at the same point on the neck, generates the wear in the shape of the helical groove over a long period of operation of the spindle.

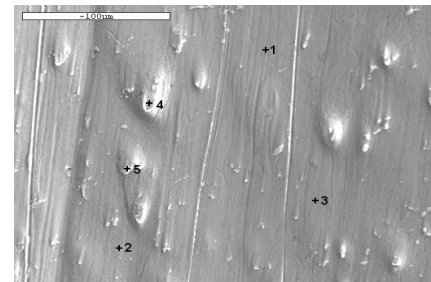
Photos of the wear surface (side surface of the helical groove), taken at a magnification 400 $\times$  of (**Figure 10**) and 1000 $\times$

**Table 2.** Percentage content of the elementary elements Al, Cu, Fe, Mg, Mn, Si at the chosen points of the wear on the side surface of the helical groove of the neck coating made of the alloy  $AlCu4Mg1$  of the spindle.

Point		Percentage content of Elementary elements, %					
		Al	Cu	Fe	Mg	Mn	Si
Matrix	Point 1	93.65	3.82	0.13	1.45	0.95	-
	Point 2	94.98	3.54	0.01	1.22	0.25	-
	Point 3	94.28	4.00	0.05	1.06	0.60	-
Phase	Point 4	62.59	23.76	8.23	0.20	3.89	1.33
	Point 5	58.92	25.24	10.04	0.14	4.58	1.08



**Figure 11.** Exemplary distribution of the elementary elements Al, Cu, Fe, Mg, Mn, Si in the  $AlCuFeMnSi$  phase (point No. 4) on the wear surface of the side wall of the helical groove of the neck coating made of the alloy  $AlCu4Mg1$  after a period of operation of about 14,000 hours with yarn of the following blend: 20  $\div$  30% of polyester fibres + 80  $\div$  70% wool fibres.

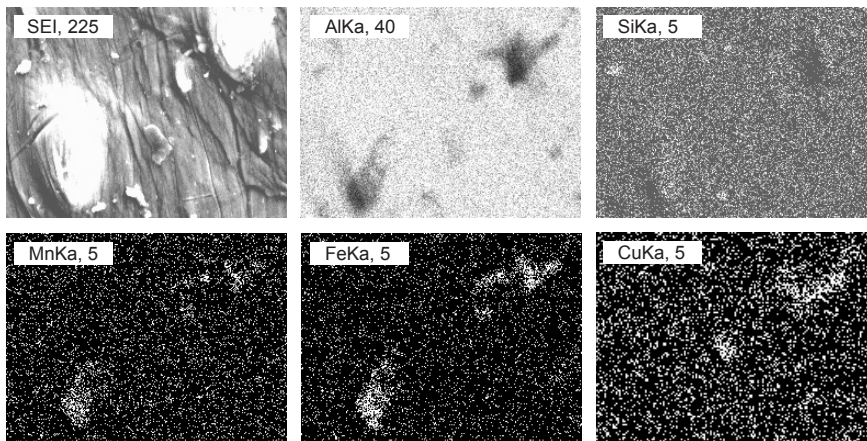


**Figure 10.** Micro-photo of the wear surface (side wall of the helical groove) of the neck coating made of the alloy  $AlCu4Mg1$  after a period of operation of about 14,000 hours with yarn of the following blend: 20  $\div$  30% of polyester fibres + 80  $\div$  70% wool fibres, magnified 400 $\times$ .

(**Figure 12** see page 38), show the layers of the matrix and precipitations, which have the form of the bright regions of the metallic phase  $AlCuFeMnSi$ . The dimples (cavities) on the surface of the neck coating occur in the area of the matrix, but the elevations are the metallic phases.

It is probably the result of the matrix having a considerably lower hardness than that of the metallic phase.

On the other hand the surface of the spindle neck coating before operation is char-



**Figure 12.** Region of wear trace at the point of yarn friction, magnified 1000 $\times$ , and the distribution of elementary elements Al, Si, Mn, Fe, Cu on the surface layer of spindle neck coating made of the alloy AlCu4Mg1.

acterized by after-machining traces and by slightly higher values of parameters  $S_a$ ,  $S_q$  and  $S_v$ , compared with the values of these parameters after a period of operation of about 14,000 hours.

The most probable thesis seems to be that the loss of material on the spindle-neck coating with an anti-balloon crown, in the form of helical groove, is caused by the separation of microvolumes of the metallic material. This is a result of micromachining using solid particles, such as grass, tree bark, straw and sometimes dust particles that are placed in the stream of fibres and move with it at a velocity of 35 m/min. These particles are pressed to the surface of the spindle-neck coating by the variable, as a result of the variable yarn tension that is caused by its cyclic entry and exit from the crown notches, as well as by the variations in the position of the spindle axis, which ends with the crown during the rotational motion. During grinding with abrasive paper, which is unwound from the roller, it can be assumed that the constant particles perform the function of local microblades. In the author's opinion, during the friction, the main role of yarn running along the surface of spindle-neck coating (obtained by anodic oxidation) with an anti-balloon crown is played by abrasive wear.

Two factors predominantly affect the intensity of this wear process: the tension of the yarn, which indirectly influences the value of the pressure at the point where the stream of fibres comes into contact with the surface of the neck coating, as well as the velocity of the yarn. Polyester fibres in the structure of the yarn, which

are characterised by greater strength than wool fibres, allow the process of spinning to be conducted with larger output. An increase in the output is directly connected to the higher speed of the yarn. However, an increase in yarn velocity [3] causes a decrease in the values of the tensioning forces of the yarn, and directly generates a larger value of yarn pressure on the guide, crown and spindle-neck coating.

### Final remarks and conclusions

The evaluation of the wear of neck coating made of the alloy AlCu4Mg1 of spindles with an anti-balloon crown during contact with the yarn proves that wear occurs in two overlapping stages. In the first stage the wear is caused by the smoothing of the surface roughness of the external surface layer. It is caused by the separation of material microvolumes during micromachining with solid particles, such as grass, tree bark, straw, but mainly by the solid dust - grains placed in the fibre stream displaced with variable tension. On the other hand, in the second stage local intensive wear occurs as a result of an inconsiderable increase in the time that one of the crown teeth holds the moving yarn. It is probably caused by an increase in the temperature in the area of contact of between the yarn and surface of the neck coating. Consequently, the shiny surface of the neck becomes matt, which probably is caused by the absorption process and oxygen diffusion on the friction surface. Simultaneously, a layer of solid solutions of aluminium with oxygen is generated. Afterwards, the solid solutions are separated under the action of friction forces. Wear by oxidation and abrasion occurs

in the second stage, and it generates a helical groove of 2 mm width and 1 mm depth on the spindle neck coating.

Observation of the wear surface proved that the wear process of the spindle neck coating, as result of micromachining, mainly refers to the matrix of the alloy AlCu4Mg1: but the hard emissions (metallic phases) are removed spontaneously as a result of bonding with the foundation (soft matrix).

On the basis of this investigation and analysis, it was concluded that abrasive wear plays a decisive role in the process of the wear of the oxide layer of neck coating made of the aluminium alloy AlCu4Mg1 during yarn friction on the surface; the abrasive wear also has a crucial impact.

Confirmation of the assumed hypothesis that there is parallel oxidising and abrasive wear requires further detailed investigation: measurement of the microhardness, microstresses and contents of oxygen in the microvolumes of wear places, i.e. the contact places yarn-alloy AlCu4Mg1.

### References

1. Lawrence C. A.; *Fundamentals of Spun Yarn Technology*, CRC Press, Leeds 2003.
2. Kragelsky I. V., Alisin V. V.; *Tribology – Lubrication, Friction and Wear*, John Wiley & Sons Inc, 2005.
3. Kowalski K.; *Identification of dynamic forces in threads manufactured by open top knitting machine on the basis of computer simulation and digital measurement technique (in Polish)*, Scientific Letters of the Technical University of Łódź 613.. Łódź 1991.
4. Szczerek M., Wiśniewski M.; *Tribologia i tribotechnika*, Ed.: Institute for Sustainable Technologies, Radom 2000.
5. Ocoś K. E., Liubimov V.; *Struktura geometryczna powierzchni*, Editorial Office of the Technical University Rzeszów 2003.
6. Pawlus P.; *Topografia powierzchni*, Editorial Office of the Technical University Rzeszów, 2006.
7. Stout K. J., Blunt L.; *Three Dimensional Surface Topography*, Penton Press, London 2000.
8. Płonka S., Hajduga M., Jędrzejczyk D.; *The Wear Model Prognose of Tribologie Couple – the steel Guide – Yarn, Fibres & Textiles in Eastern Europe*, (2007) Vol. 15, No.2 (61), pp. 54-57.

Received 04.08.2006 Reviewed 09.04.2007