

E. P. Akçakoca Kumbasar,
H. Aydin,
Z. Ondogan,
M. Ozcelik,
E. N. Ondogan

Ege University
Department of Textile Engineering
35100 Bornova, Izmir, Turkey
E-mail: perrin.akcakoca@ege.edu.tr

Automatic Indigo Measurement System as Part of a Dosing System for Indigo Dyeing

Abstract

Indigo dye has been widely used for dyeing traditional blue denim products intended to give a worn faded look. However, while using the warp yarn dyeing process with indigo dye often occur problems of colour variation. To prevent colour variation, controlling the indigo dye baths is an important factor. The objectives of this study include adjusting dosages of leuco indigo, hydrosulphite, pH (caustic), using an automatic measurement and dosing system taking redox titrations as the basis. It was observed that measurements carried out with this system became more reliable and also had a positive effect on the quality of the product.

Key words: indigo dye, denim products, dye bath control system, automatic measurement system, titration.

Introduction

Denim is a heavy fabric that is woven diagonally; generally it has a 1/2, or 2/1 or 3/1 twill structure. The inner layer of denim fabrics, produced in a double weave, is white, while the outer layer is indigo-dyed. The 'used' effect of the fabric, like the result of abrasion, is the most important feature of denim fabrics. The whiteness of the inner layer emerges as the abrasion starts, and the desired 'used effect' is achieved [1].

The main features of indigo-dyed denim fabrics which are demanded on the market are listed below:

- low washing fastness, and thus the natural fading out of the initial dark colour by usage and home-washing,
- average light fastness, and
- low dry-rubbing resistance.

Originally, the indigo dye used for denim fabrics used to be produced in the past from leaves of the *Indigofera Tinctoria* L. plant, which commonly grew in tropical and subtropical climates (especially in India and China). Today, indigo is obtained synthetically by using N-phenylglycine and N-phenylglycine-o-carboxylic acid. Indigo, which is a member of the vat dyes, is not soluble in water (Figure 1). Solubility of indigo in water solutions is only possible in alkaline and reducing mediums, whereas alkaline salts of leuco indigo are water-soluble [1 - 4].

The solution takes a yellow colour when the blue-coloured indigo is reduced to the leuco compound. This yellow-coloured compound dyes cellulose, and this reduced product is oxidised on the fibre by the oxygen from air to blue-coloured indigo. The main reducing agent used in indigo dyeing for typical vat dyes is

sodium dithionite, called hydrosulphite. Reducing the potential of hydrosulphite fulfils all practical demands. Other reducing agents are used for special purposes only, and they have not yet gained practical acceptance [3].

An excess of hydrosulphite must be present in the dyeing bath because sodium dithionite is sensitive to atmospheric oxygen. Sodium dithionite is oxidised by consuming NaOH when atmospheric oxygen is present in the alkaline medium. Indigo that has been reduced and has taken the leuco form during vatting takes the form of oxidised indigo during the oxidation process. Depending on the pH (Table 1), the reduced form of indigo may occur in the mono-anion or di-anion form.

As is already known, the inner layer of indigo-dyed warp yarns is white, whereas the outer layer is coloured; this phenomenon is called ring dyeing. The ring dyeing characteristic is determined by the regulation of the pH value. Leucoindigo has the form of a mono-anion at pH 11, and displays a better ring-dyeing property. When the pH changes to about 13, a decrease in the ring-dyeing property is observed as the penetration increases [5 - 7].

In the caustic-hydrosulphite method, which is widely used for reducing indigo, it is generally not possible to prepare an

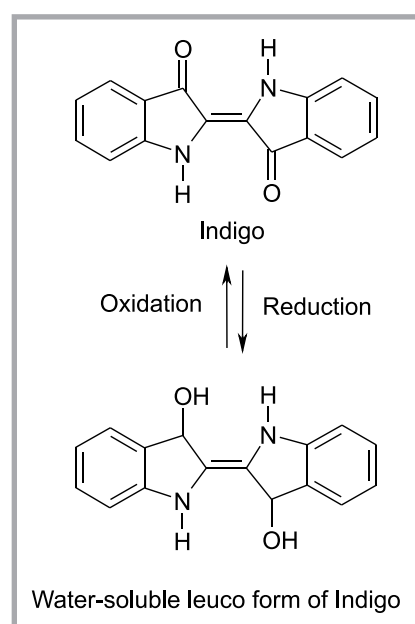

Figure 1. The reducing/oxidising reactions of indigo [2].

indigo vat with a concentration of more than 80 g/l (of 90-95 g/l in new systems), because of the solubility problem. The reducing temperature is accepted as 50 °C, and the vatting time is at 30 minutes. The vat turns yellow when reducing is completed, and turns green within 12-15 seconds when a clean glass is plunged. If it is not clear and yellow, or if it turns to green very quickly, a

Table 1. Reduction of indigo connected with pH.

Parameter	vatting	
	Indigo oxidised	Indigo reduced
		<div style="display: flex; justify-content: space-around;"> mono-anion form di-anion form </div>
Clustering	dispersed clusters	soluble clusters
Penetration	bad	good
pH	10.5 - 11.0	>13
Ring dyeing	more	less

small amount of hydrosulphite must be added. This is the simplest method for controlling the vatting of indigo dyes. An excess of hydrosulphite results in irregular dyeing and increases ecological damage.

■ Dye-bath property control

Today, the competitiveness of denim producers in the international textile market is only possible when they can achieve repeatability of the colour and washing characteristics of sewn goods. Denim producers must consider the problems of cost and environmental pollution while executing these demands. For this reason, it is very important to control the pH and the concentrations of hydrosulphite and leuco indigo. Eters [5 - 7] has pointed out that pH changes of indigo baths between pH 10.6 and pH 11.4 do not change the colour tone much, while a pH range between pH 12.2 and pH 12.9 has a negative effect on the colour efficiency. Thus, small changes in buffered baths adjusted to pH 11 do not affect the repeatability of the colour, whereas changes in pH of baths adjusted to 12.5 may have a negative effect on the colour repeatability. Checking the amount of leuco indigo and the consumption of hydrosulphite is also very important from the point of view of repeatability [7].

Checking indigo baths by means of photometric techniques, such as the following, is a fairly old method [8]:

- direct determination in the oxidised form,
- determination of the reduced form (leuco form),
- solvent techniques, and
- chemical modification techniques.

Moreover, checking the indigo baths using redox titration and voltammetric methods is also possible [9-16]. However, commercial usage of the voltammetric method is not widespread in indigo installations. On the other hand, certain problems are encountered in the redox and photometric methods:

- Measurements are seldom as precise as desired.
- Before the sample is taken to the laboratory to be measured, the indigo dye solution may lose some of its properties.
- The rate of repeatability of the measurements decreases.
- Measurement results vary depending on several factors, such as the person carrying out the measurement, the temperature of the environment, the

freshness of the chemical auxiliary agents used, the calibration and cleanliness of the equipment.

However, even these spectrophotometric examinations might be misleading as far as results are concerned. The reason for this is that particles occurring in the sample to be measured may cause significant defects in the measurement process. If the sample is filtered so as to eliminate these particles, then its chemical composition may change. Due to such problems, colour and quality variations can sometimes be observed in dyed yarns, which in turn causes colour and quality differences in the final product, i.e. the garment. Thus, experience is a significant factor in the control of indigo dyeing baths.

As is true for many cases, the automatic measurement of indigo baths will have a significant effect on the results. As the factor of manpower decreases, the liability of the results will increase. However, even today, many metrology specialists do not take this fact into consideration, and deny the advantages of automatic measurement systems. Especially where measurement sensitivity is very important, as it is for indigo dyeing, automatic measurements have a direct and significant influence on the results and increase in quality and efficiency.

Manual measurement systems are not fast enough, and temporary fluctuations in the measurement values cannot be observed within the required time and demanded sensitivity. This was why we started to develop a system where measurement intervals could be increased in comparison to traditional manual systems, and measurement values could be observed with the required sensitivity. As a result of this, the dosage changes of the substances fed into the dyeing bath could be made more quickly, and so the stability of the dyeing in the tanks was achieved more easily.

The aim of this research was to develop a system which would not be dependent on manpower for controlling and measuring the indigo baths, and would thus increase the stability of the quality and repeatability. The following assumptions of the advantages of the system we developed have been accepted;

- The problems of repeatability in conventional redox measurement systems were eliminated.
- As the life of the redox measurement probe is limited to a certain period of

time, we aimed to prevent any loss in the lifetime of the probe by including an ultrasonic cleaning technique into the system.

- The dosing amount is fixed in a unit period.
- The pH of the medium must be controlled and balanced by the system.

Furthermore, the hydrosulphite used in indigo dyeing decomposes under the presence of atmospheric oxygen especially in an alkaline medium. Decomposition increases when hydrosulphite is dosed to indigo dyeing lines in fluid form. In the system designed, we accepted the feeding of hydrosulphite to the indigo dyeing lines in solid form, aiming to reduce the hydrosulphite consumption.

■ Experimental - The automatic indigo dosing system

Our ultimate aim was to develop an automatic dosing system for indigo dyeing consisting of a system for dosing and one for on-line measuring concentrations of the leuco indigo and hydrosulphite, and controlling the pH of indigo baths, taking redox titrations as a basis. Automatic dosing of leuco indigo, hydrosulphite (Na-Dithionite), and caustic, as well as temperature control and, conductivity measurement of the indigo dye baths are provided. Our study was planned in two stages. In the first stage, an on-line measurement system with an ultrasonic cleaning technique, which is the subject of this paper, was developed and an attempt was made to use it as a prototype in an indigo installation.

In the second stage, a dosing system has been developed for dosing hydrosulphite in powder form. At present, research is still being continued for the second stage, and details of this system will be introduced in the second part of this study. However, the operating principle of the dosing system can be defined as follows: the system can work either manually or automatically. In the manual version, fixed dosing is carried out in amounts requested by the operator. For the automatic version, the concentrations of baths (leuco indigo and caustic) to be dosed, and values to be set are entered into the computer. In the time interval calculated according to the circulation inertia of the main dyeing tanks, the measurements are started. Amounts of dosing in the dye kitchen are calculated according to the measurement results, and the necessary increases or reductions are made.

The system tries to stabilise the concentrations with certain inertia. In addition, the information coming from the dyeing line of whether the system is working or not is evaluated in the dosing system. Dosing is also deactivated when the dyeing line stops (because of cessation or breakdown). When the indigo dyeing process is completed, the system washes the dosing line with soft water to prevent any particles remaining in the pipes and pumps.

Experimental – The automatic indigo measurement system

Equipment

The following equipment was used for the measurement system: a sampling tube, a redox probe, an electronic redox-meter, a pH probe, an electronic pH meter, a conductivity sensor, an electronic conductometer, a temperature sensor, an electronic control system with a 16 - 32 bit microcontroller, a computer, an ultrasonic cleaner (under the sampling tube), an electronic control for the ultrasonic cleaner system, a pressure compensation tube, 7 pieces of quality stainless valves, 316 various quality stainless pipes, 2 pieces of membrane pumps, and a circulation pump.

Method

Automatic redox titration is the measurement method applied. This method was one of the first methods developed for titrimetric analyses. For monitoring the electrochemical potential of redox titrations, the following operations are provided:

- Concentrations are calculated in accordance with the Nernst equation [17].
- Hypothetical reaction

$$A_{\text{red}}(\text{analyte}) + T_{\text{ox}}(\text{titrant}) = A_{\text{ox}} + T_{\text{red}}$$
- $E_{\text{rxn}} = E_{T_{\text{ox}}/T_{\text{red}}} - E_{A_{\text{ox}}/A_{\text{red}}}$
- After each addition of the titrant:
 1. The system reaches a balance.
 2. Electrochemical potential of reaction is $E_{\text{rxn}} = 0$
 3. $E_{T_{\text{ox}}/T_{\text{red}}} = E_{A_{\text{ox}}/A_{\text{red}}}$
- One of the potentials of half-reaction can be used to monitor the advance of the reaction.

Characteristic points on the titration curve :

- Region before the equivalence point: This is composed of a mixture of oxidised and reduced forms of the analyte.
 - The Nernst equation is used to calculate the potential of the half-cell reaction of the analyte to be measured
 - $E = E^0_A - 0.05916/n \log [A_{\text{red}}]/[A_{\text{ox}}]$

- Region after the equivalence point: This is composed of the oxidised form of the analyte, and calculating the potential of the half cell reaction of the titrated agent is very easy with the aid of the Nernst equation.
- Region around the equivalence point: It is hard to calculate the potentials of the reaction by using the Nernst equation alone.
 - The concentrations of molecules A_{red} and T_{ox} are extremely low.
 - Two half-reactions must be combined together by the Nernst equation.

In the 'automatic redox titration system', the sample is taken from the dye bath in definite amounts, and the titration agent is fed until the equivalent point is reached, while intermediate measurements are made. The REDOX titration measures the amount of leuco indigo and hydrosulphite with the aid of appropriate oxidation agents, such as potassium-hexa-cyanoferrate (III). The measurement is performed in a nitrogen atmosphere.

Measurements can be made at any time requested, or in a time-regulated way (for example once every 20 minutes). For every measurement, the system records the date, hour, pH, temperature, salt amount measured, titration curves, and amounts of leuco indigo and hydrosulphite obtained from the titration curves on the hard disk of the computer. At any time, data from the previous days can be viewed, and a printout taken from the printer. Moreover, the system can be connected to the network, and thus data can be examined on a distant computer.

Results and discussion

In this study, the system was designed as a closed system. A sampling tube and a pressure compensation tube are connected to each other. The bath sample taken into the sampling tube can be forced to circulate at a desired speed with the aid of a circulation pump. In the sampling tube, there are inlets for soft water, the indigo bath, the titrator chemical and dispersing agents, and an outlet for waste drainage. The pressure compensation tube contains an opening to the atmosphere, a bath returning line and a waste drainage line.

When the system is idle, it holds soft water in the sampling tube. The aim of this is to prevent drying and thus disruption of the pH, redox and conductivity sensors. When measurement starts, the bath

inlet, the circulation inlet and the bath-return line are activated. The circulation pump works at a high speed, and circulation from bath to bath starts.

Circulation continues for about 2 minutes. The aim is to obtain new (fresh) samples from the bath. At the end of 2 minutes, the bath temperature, pH and salt amounts are measured and recorded. Then the circulation pump, bath inlet and bath return-lines are closed.

Circulation and waste drainage outlets are opened, and the sample fluid is poured into the sampling tube until it reaches a fixed level adjusted previously. After the level is fixed, the waste drainage line is closed. A fixed amount of dispersing agent (Setamol WS-BASF 1N) is dosed into the sampling tube with the aid of a dosing pump, and the titration process starts.

During the titration process, the circulation pump works at a low speed to prevent foaming of the sample fluid; in other words, the fluid in the sampling tube is itself circulated at a low speed.

The titrant substance (Potassiumhexacyanoferrate $K_3(Fe(CN)_6)$ 0.1 N) is dosed to the sampling tube with pulses of 0.5 ml/sec each time. For each dosing, the redox mV value is recorded.

Titration continues until the redox mV value reaches 0 mV (the end of the redox reaction). The amounts of leuco indigo, hydrosulphite and other agents are calculated with the aid of an algorithm that is prepared from the curve obtained after ends of the titration for the evaluation of equivalence points, and these amounts are recorded together with the repetition (RPT) of the titration curve of $\pm 2\%$.

After the measurement is completed, the circulation stops, the fluid in the sampling tube is discharged by activating the waste drainage line, and washing starts.

The system uses soft water in the washing process, circulates the soft water and removes the chemicals settled on the surfaces of the sampling tube and the measurement probe by starting the ultrasonic cleaner; it also prevents the chemicals from entering into the probe by cleaning the membranes of the probe. The washing process is done with three repetitions. Soft water is taken in 3 times and circulated, and at that time the ultrasonic cleaner is activated and waste is discharged. When soft water is taken in

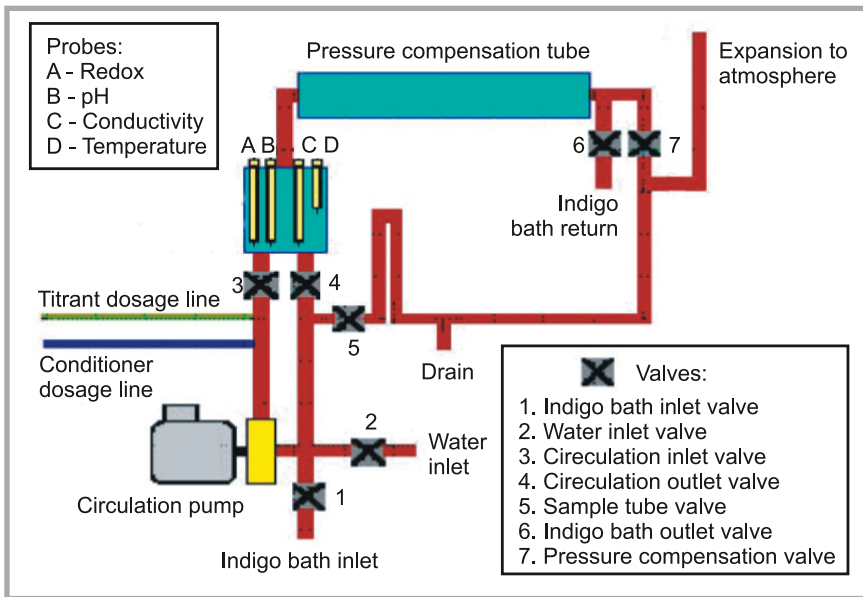

Figure 2. Schematic view of indigo measurement system.

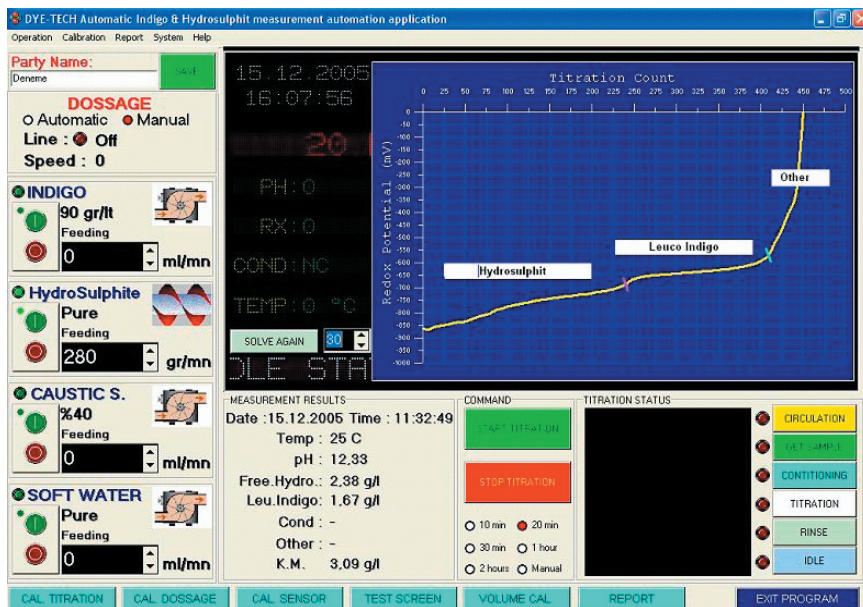

Figure 3. View of the control panel with screen and an example of titration curve.

for the 4th time, it is left in the sampling tube to prevent drying and thus disruption to the pH, redox and conductivity sensors.

The schematic view of the designed system is given in Figure 2. In the system that has been developed, the leuco indigo amount, the hydrosulphite amount, the pH (caustic), heat and conductivity of the indigo dye baths were measured, at a repetition of 20 min (when desired the repetition time could be changed) and the leuco indigo caustic hydrosulphite and the water required for the system were dosed automatically. Under laboratory conditions, the measurement probes were controlled by carrying out multiple

measurements, and we could state that the quality values were determined with an error of $\pm 2\%$.

The redox reaction is like the fixation of reduced indigo (leuco-indigo) oxidised with air, as it is in the dyeing process. In the measurement system, the number of equivalence points will be the number of agents measured. The amount of the titration agent used until the equivalence points are reached is evaluated in proportion to the concentration of every agent to be measured, and concentrations are calculated at the end of this process. An example of the titration curve is shown in Figure 3.

As can be seen from the example of the titration curve, 26 titrant doses in 120 ml of sample measurement solution (26×0.5 ml 0.1 M potassium hexacyanoferrate) enabled the oxidation of hydrosulphite, and 164 titration doses have provided oxidation of leuco indigo. The amounts of hydrosulphite and leuco indigo in the 120 ml sample solution can easily be calculated with the aid of the amounts of the titrant used. The system is controlled from the computer screen (Figure 3).

All the assumptions accepted previously were achieved and confirmed by the working of the measuring system while dyeing with indigo manual, and also in the automatic indigo dosing system. For this aim, the results of the manual method performed with the use of a laboratory-type redox titration system and the automatic measurement method were compared. In the first stage the amount of hydrosulphite was fixed as 0.5 g/l. Then, the pre-reduced liquid indigo (DyStar) was added to the system with a concentration range of 0.7-2.2 g/l with the use of the Foxpro (DyStar) system. The indigo concentration was increased by 0.2 g/l each time. The dye bath was circulated, and 20 minutes after each addition the leuco indigo concentration was measured with manual and automatic methods (Figure 4). As can be seen from Figure 4, indigo concentrations measured with manual and automatic methods were found to be similar.

Next, the indigo concentration was fixed as 0.8 g/l, and hydrosulphite in the concentration range of 0.4 - 0.7 g/l was dosed into the system. The hydrosulphite concentration was increased by 0.1 g/l each time. In a similar way, the hydrosulphite concentration was measured with manual and automatic methods (Figure 5). Figure 5 shows that the results achieved by the automatic measurement method are more stable than those of the manual method. In the automatic measurement system, both samples are taken from the main circulation line and measured. On the other hand, samples taken from indigo baths are carried to the laboratory for the manual measurement method. In the meantime, hydrosulphite can decompose with an excess of oxygen in the medium. Thus, it is more difficult to obtain stable measurement results with the manual method.

Over the trials, the conductivity (mS/cm) and pH of the dye bath were measured with manual and automatic methods, and the results were compared (Figures 6 and 7).

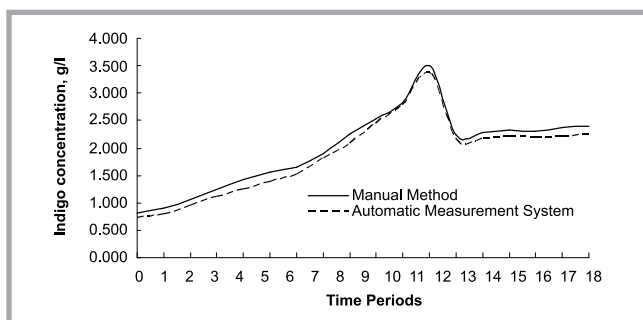

Figure 4. Comparison of the indigo concentrations in the dye bath with manual method and automatic measurement system.

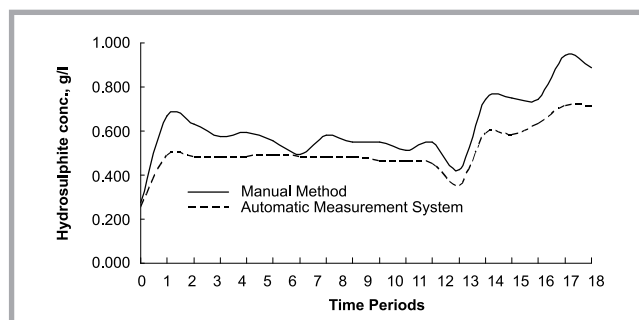

Figure 5. Comparison of the hydrosulphite concentrations in the dye bath with manual method and automatic measurement system.

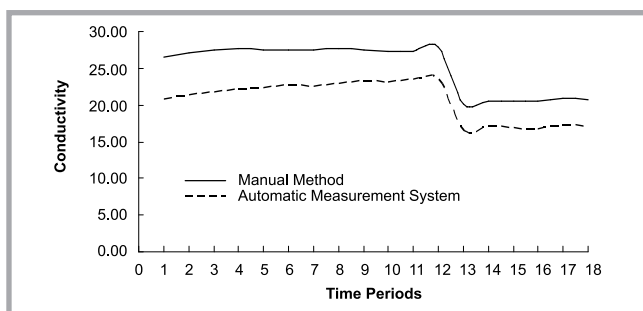

Figure 6. Conductivity measurements of the dye bath with manual method and automatic measurement system.

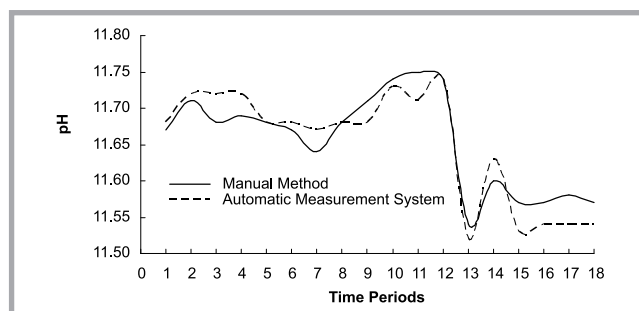

Figure 7. pH measurements of the dye bath with manual method and automatic measurement system.

Figure 6 indicates that differences of 25% can be observed between the measurement values of both systems, even though the conductivity curves are parallel to each other. However, the fact that the curves are parallel to each other leads us to think that the difference between the measurements is caused by the calibration of the probe. In addition, no significant difference was stated between the pH values measured in both of the methods.

According to Figures 4 - 7, it can be said that control of the hydrosulphite amount can be performed in a more precise way with the automatic measurement system, even though very similar results are obtained with manual and automatic measurement methods determining the indigo concentration. Additionally, it must be considered that the automatic system is independent of humans, and yields results in a shorter time.

Conclusions

This advanced technology will enable the conventional methods to be cross-examined. It is possible to classify the advantages of this method as follows:

- Measurements can be done with the required precision.
- The reproducibility of the measurements will increase.
- Colour differences that may occur

in the indigo production line will be minimised.

- Standardisation of production will be achieved.
- The human factor in the production process will be minimised.
- Quality of the production will increase.
- Production efficiency will increase.
- The quality of the goods will increase.
- The added value of the product will increase.
- Costs will decrease.
- Waste will decrease with the aid of production standardisation.
- More production with lower costs and higher quality will be achieved in a shorter period of time.

All these factors eliminate colour and quality differences in the dyed yarns that are produced, and increase the quality standardisation of final indigo products.

References

1. Akcakoca, E.P, *Tekstil ve Konfeksiyon*, 6, No. 2, 136-143, 1999.
2. [www.cht-group.com/19.05.2003\(JEANS-The Blue Phenomenon\)](http://www.cht-group.com/19.05.2003(JEANS-The Blue Phenomenon))
3. Shore, J., *Colourants and Auxiliaries, Vol 1-Colourants, Society of Dyers and Colourists*, 1990, 251
4. Haas, L., *ITB Dyeing, Printing, Finishing*, 2/90, 45-50
5. Etters, J.N., *American Dyestuff Reporter*, March 1992, 17-24
6. Etters, J.N., *American Dyestuff Reporter*, March 1993, 30-33,50
7. Etters, J.N., *American Dyestuff Reporter*, June 1994, 26-29,39.
8. Bechthold, T., E. Burtscher, O., *Bobleter, Textil Praxis International*, 1992, 44-49.
9. Smeller, J. M., S. D. Leigh, *Journal of Research of the National Inst. of Standards and Technology*, Vol. 108, No. 1, January-February 2003, 49-55
10. Govaert, F., E. Temmerman, P. Kiekens, *Anal. Chim. Acta*, 1999, 385, 307-314
11. Alvarez, M. J. B., C. F. Bobes, M. T. F. Abedul, A. Costa-Garcia, *Anal. Chim. Acta*, 2001, 442, 55-62
12. Roessler, A., O. Dossenbach, W. Marte, P. Rys, *Dyes and Pigments*, 2002, 54, 141-146.
13. Roessler, A., D. Crettenand, O. Dossenbach, W. Marye, P. Ryes, *Electrochimica Acta*, 2002, 47, 1989-1995.
14. Alvarez, M. J. B. , M. T. F. Abedul, A. Costa-Garcia, *Anal. Chim. Acta*, 2002, 462, 31-37
15. Fernandez-Sanches, C., A. Costa-Garcia, *Electro. Chem. Commun.*, 2002, 2, 776-781.
16. Roessler, A., X. Jin, *Dyes and Pigments*, 2003, 59, 223-235.
17. Tural, H., *Analytical Chemistry*, Ege University Press, 1997, 139-180.

Received 07.04.2005 Reviewed 20.01.2006