

# Model of the Feeding Process of Anisotropic Warp Knitted Fabrics

## Abstract

The model of the feeding process of anisotropic warp knitted fabrics includes a mathematical model of a knitted fabric in which the surface distribution of variable features of the knitted fabric structure is defined in the form of numerical matrixes, the criteria of selecting the feeding method are defined on the basis of the existing technologies and the definition of forcing the feeding system on the basis of the kinematics of loop-forming elements, and finally the gradient of length of the fed and required threads in structural elements of the knitted fabric. Identifying the feeding system dynamics at constant-length thread feeding formulates the assumptions of the physical model. The mathematical model describes time courses of variations in dynamic forces in threads in a stitch repeat. On the basis of the algorithm of calculations, a numerical simulation of thread feeding was carried out for the structure of a jacquard knitted fabric, determining the extreme values of forces in the fed warp threads.

**Key words:** warp knitting, anisotropic warp knitting, feeding, surface distribution, mathematical model.

## Introduction

A characteristic feature of anisotropical knitted fabrics is the variation in the component stitches surface structure. The stitches form a given combination of threads of structural elements, of different spatial configurations and different lengths. In the process of manufacturing warp anisotropical knitted fabrics, selecting the optimum parameters for feeding the knitting zone of warp knitting machines with threads is a key factor in programming the technological process [1]. The model of feeding assumes a system of active warp unwinding from warp beams with a constant or variable programmed rotational speed of the beams.

The model of feeding the manufactured anisotropic warp knitted fabric with warp threads is presented in the form of an algorithm with defined successive steps of the model partial solutions (Table 1).

- Step 1 - a mathematical model of an anisotropic warp knitted fabric described in the form of numerical matrixes of  $A_i$  component stitches [2].
- Step 2 - a geometrical-empirical model of the structural elements of the fabric.
- Step 3 - a definition of numerical matrixes  $L_i(V_i)$  of surface distribution of the thread length in stitch repeat.
- Step 4 - determining the thread gradient  $\Delta l_{r,k}$  according to one of four possible methods of constant-length thread feeding.
- Step 5 - a condition of selecting the feeding method according to criteria determining that the thread gradient in the last formed course is close to zero, and

that the overfeeds and deficiencies of threads between the lengths of fed warps and thread requirements in structural elements of the knitted fabric have minimum values.

- Step 6 - defining the forcing of the feeding system  $S(t)$ , which is the sum of:  $S'(t)$  - forcing conditioned by displacement of knitting elements of the warp-knitting machines, back displacement of threads in the knitting zone, type of stitch, conditions of fabric take-up. The forcing was determined empirically by digital analysis of pictures of the three-

ad moving between the back rest roller and the needles.

$\Delta S(t)$  - the forcing defined by variation of the thread run-in gradient for the selected feeding method.

- Steps 7 and 8 - a mathematical model of the feeding process describing the time courses of the back rest roller deflections  $y(t)$  and the variability of the dynamic forces in threads forming a stitch repeat. The mathematical model was formulated on the basis of the physical model of the feeding process presented in the following chapter.

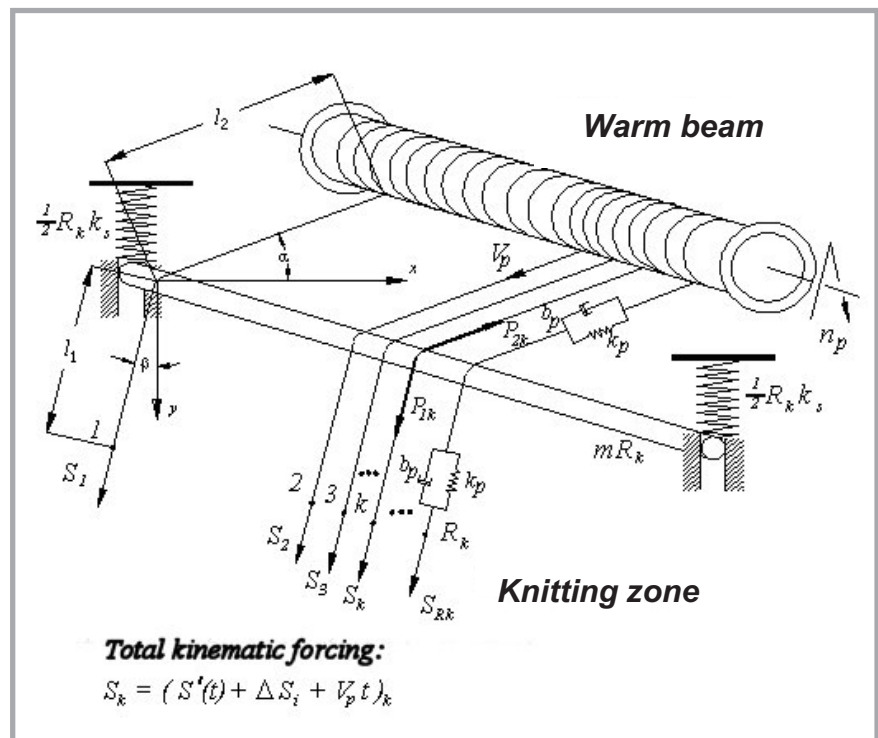

Figure 1. A physical model of a constant-length feeding system.

**Table 1.** Algorithm of the feeding model.

Step 1	Defining numerical matrixes of i-th component stitches. Numerical matrix of the i-th component stitch $A_i = \{a_{r,k}\}$ or $A_i = \{B\}$ for $r = 1$ to $R_r$ , $k = 1$ to $R_k$ where $R_r$ , $R_k$ - height and width of a stitch repeat.
Step 2	Assigning an element of matrix $A_i$ to the value of thread length $l_i$ $a_{r,k} = l_i$ , where: $l_i = f(A, B, d, k_e)$ , $A, B, d$ - dimension parameters of the fabric, $k_e$ - empirical coefficient of the open model
Step 3	Describing numerical matrixes of thread lengths $L_i$ of the i-th component stitch $L_i = \{l_{r,k}\}$ Transformation of matrix $L_i$ into symmetrical matrix $L'_i$
Step 4	Determining gradients of thread run-in's $\Delta l_{r,k}$ for element $a_{r,k}$ $\Delta l_{r,k} = (l_{r,k})_p - (l_{r,k})_z$ : where: $(l_{r,k})_p$ - length of the fed thread, $(l_{r,k})_z$ - length of the required thread, according to a given method of thread feeding:  ' A': $(\Delta l_{r,k})_A$ - feeding $l_p = \overline{l}_{r,k} = \sum_{r=1}^{R_r} \sum_{k=1}^{R_k} l_{r,k} = const$ (average requirement $l_z$ within the limits of a stitch repeat)  ' B': $(\Delta l_{r,k})_B$ - feeding $l_p = (\overline{l}_r)_k = \left( \frac{\sum_{r=1}^{R_r} l_{r,k}}{R_r} \right)_k$ (of a variable thread length of $\overline{l}_z$ in a group of threads at the height of the stitch repeat)  ' C': $(\Delta l_{r,k})_C$ - feeding $l_p = (\overline{l}_k)_r = \left( \frac{\sum_{k=1}^{R_k} l_{r,k}}{R_k} \right)_r$ (of a variable thread length of $\overline{l}_z$ in the fabric course) " D": $(\Delta l_{r,k})_{B+C}$ - feeding a variable thread length in a group of threads of $l_p$ , equal to the average requirement $l_z$ in courses of a separated group of threads.
Step 5	Selecting a feeding method 'A', 'B', 'C', 'D' according to the criteria meeting the following conditions: $\Delta l_{r,k} \equiv 0$ for $r = R_r$ (for the last course of the stitch repeat),  $\left  +\Delta l_{r,k} \right _{\min}$ - thread overfeed in element $a_{r,k}$ , $\left  -\Delta l_{r,k} \right _{\min}$ - thread deficiency in element $a_{r,k}$
Step 6	Defining the function of thread forcing $S(t)$ in the feeding process $S(t) = (S'(t) + \Delta S_{r,k})$ for threads $k = 1$ to $R_k$ , $S'(t)$ - forcing conditioned by the displacement of knitting elements in the warp-knitting machine, $\Delta S_{r,k} = -\Delta l_{r,k}$ a component variable of forcing defined by the gradient of thread run-in's
Step 7	Determining dislocations of the back rest roller $y(t)$ on the basis of identification of the feeding system dynamics  $R_k \cdot m \cdot \frac{d^2 y}{dt^2} + b_{zr} \cdot \frac{dy}{dt} + k_{zr} \cdot y = a_1 \left[ k_p \cdot \sum_{k=1}^{N_1} S_1(t) + b_p \cdot \sum_{k=1}^{N_1} \frac{dS_1}{dt} \right] +$ $+ a_2 \left[ k_p \cdot \sum_{k=1}^{N_2} S_2(t) + b_p \cdot \sum_{k=1}^{N_2} \frac{dS_2}{dt} \right] + a_3 \left[ k_p \cdot \sum_{k=1}^{N_3} S_3(t) + b_p \cdot \sum_{k=1}^{N_3} \frac{dS_3}{dt} \right]$ where: $a_1, a_2, a_3$ - coefficients describing the construction of the feeding system, $b_{zr}$ - coefficient of the system attenuation $k_{zr}$ - coefficient of the system elasticity
Step 8	Determining the dynamic loads in threads $P_{1k}(t)$ :  $P_{1k}(t) = \frac{1}{l_2 e^{\pm \mu \cdot \rho} + l_1} \left[ k_p S_k(t) + b_p \frac{dS_k}{dt} - k_p (\cos \beta - \sin \alpha) y - b_p (\cos \beta - \sin \alpha) \frac{dy}{dt} \right]$

## Identification of the Feeding System Dynamics at Constant-length Thread Feeding

A physical model of the feeding system in a warp-knitting machine at constant-length thread feeding in the process of manufacturing anisotropic structures (Figure 1) was defined for the following assumptions:

- a quasi-flat system referred to  $k$  warp threads in the width of the stitch repeat  $R_k$ ,
- parameters of the system described by stiffness, the reduced mass of the back rest roller, elasticity and attenuation of threads. Threads are treated as weightless viscoelastic bodies,
- the assumed physical model reflects the geometry of the warp thread feeding zone,
- at a given direction of thread movement on the back rest roller, the physical model is a system subject to variable kinematic forcing  $S_k(t)$ ,
- the physical model allows for the hysteresis of thread loads caused by their friction against the back rest roller,
- the back rest roller is treated as an inflexible element, elastically supported in such a way that it has one degree of freedom of movement.

### Symbols used in Figure 1:

- $P_{1k}$  - tension in k-th thread between the back rest roller and the knitting zone,
- $P_{2k}$  - tension in k-th thread between the warp beam and the back rest roller,
- $m$  - point, reduced to one thread, mass of the back rest roller,
- $k_s$  - coefficient of the back rest roller stiffness reduced to one thread,
- $k_p$  - coefficient of thread elasticity,
- $b_p$  - coefficient of thread attenuation,
- $l_1, l_2$  - geometrical parameters of the system,
- $\alpha, \beta$  - geometrical parameters of the system,
- $n_p, v_p$  - rotational and linear speed of thread feeding ( $n_p = const.$  and  $v_p = const.$  for constant-length warp unwinding),
- $R_k$  - wale repeat of the stitch describing the number of threads affecting the back rest roller,
- $S_k$  - total kinematic forcing of the feeding system,
- $S'(t)$  - cyclic forcing during formation of one course of fabric,
- $\Delta S_i$  - growth of forcing equal to the gradient of thread run-ins.

## Mathematical Model of the Feeding System

The physical model of the feeding system dynamics (Figure 1) can be described by the equation of motion (1) where:

$e^{\pm\mu\rho}$  - the quantity describing the interrelation between forces  $P_{1k}$  and  $P_{2k}$ ;

$$P_{2k} = P_{2k} \cdot e^{\pm\mu\rho} \quad (2)$$

$\mu$  - the coefficient of friction between the back rest roller and the thread moving on the back rest roller,

$\rho$  - the angle of encirclement of the back rest roller with thread.

Taking into account the properties of warp threads in the physical model, as described by the Kelvin-Voigt model, forces  $P_1$  and  $P_2$  can be presented by equation (3) and (4), where  $\lambda_{1k}$ ,  $\lambda_{2k}$  - the thread elongation after and before the back rest roller. Substituting relations (3) and (4) to equation (2), we obtain equation (5).

From the condition of warp thread continuity

$$S(t)_k = (S'(t) + \Delta S)_k = \lambda_{1k} + \lambda_{2k} + y(\cos \beta - \sin \alpha) \quad (6)$$

we can determine the quantity:

$$\lambda_{2k} = S(t)_k - \lambda_{1k} - y(\cos \beta - \sin \alpha) \quad (7)$$

Placing relation (7) in equation (5), we obtain equation (8). After transformations and grouping of terms, relation (8) can be written as equation (9).

The left side of relation (9) is the value of force  $P_{1k}$  (equation (1)), hence by placing the above relation in the equation of motion (1) and rearranging it we obtain equation (10), where:

$b_\pi$  - the coefficient of the system attenuation

$k_\pi$  - the coefficient of the system elasticity,

$a_1, a_2, a_3$  - coefficients describing the geometry of the feeding system,

$N_1$  - the number of threads moving on the back rest roller in the direction of the warp beam, when condition 1 is fulfilled:

$$\Delta S - V \cdot \Delta t - \Delta \lambda_1 - \Delta \lambda_2 < 0 \quad (11)$$

for:

$\Delta S$  - the growth of the kinematic forcing of the system,

$\Delta \lambda_1, \Delta \lambda_2$  - growth of thread elongation in the arms of thread  $l_1$  and  $l_2$ ,

$V$  - the speed of thread delivery,

$\Delta t$  - the step for discrete calculations after time.

$N_2$  - the number of threads moving on the back rest roller in the direction of needles, when condition 2 is fulfilled:

$$\Delta S - V \cdot \Delta t - \Delta \lambda_1 - \Delta \lambda_2 > 0 \quad (12)$$

$N_3$  - the number of threads not moving on the back rest roller, when condition 3 is fulfilled:

$$\Delta S - V \cdot \Delta t - \Delta \lambda_1 - \Delta \lambda_2 = 0 \quad (13)$$

$$N_1 + N_2 + N_3 = R_k$$

Depending on one of the three defined conditions of thread movement on the back rest roller, coefficients  $a_1$ ,  $a_2$  and  $a_3$  have the values:

■ for the group of threads  $N_1$  (condition 1)

$$a_1 = \frac{\cos \beta - e^{-\mu\rho} \cdot \sin \alpha}{l_2 \cdot e^{-\mu\rho} + l_1} \quad (14)$$

■ for the group of threads  $N_2$  (condition 2)

$$a_2 = \frac{\cos \beta - e^{-\mu\rho} \cdot \sin \alpha}{l_2 \cdot e^{-\mu\rho} + l_1} \quad (15)$$

■ for the group of threads  $N_3$  (condition 3)

$$a_3 = \frac{\cos \beta - \sin \alpha}{l_2 + l_1} \quad (16)$$

Coefficients  $b_\pi$  and  $k_\pi$  are determined from relations (17) and (18).

Since:

$h$  - the relative coefficient of system attenuation,

$$h = \frac{b_{sr}}{2mR_k} \quad (19)$$

and  $\omega_0$  - the frequency of free vibration of the non-attenuated system,

$$\omega_0 = \sqrt{\frac{k_{sr}}{m \cdot R_k}} \quad (20)$$

equation (10) has the form presented in (21).

According to conditions (11), (12) and (13), the forces in threads  $P_{1k}(t)$  for the successive steps of calculations are determined from the following relations:

■ for condition 1 - the relation (22),

■ for condition 2 - the relation (23), and

■ for condition 3 - the relation (24).

## Realisation of the Feeding Model Algorithm for the Structure of a Jacquard Warp Knitted Fabric

The subject of analysis is the structure of a jacquard warp knitted fabric constructed from two component stitches. The first component stitch forms a repeatable set of open chain loops; the other is the weft stitch of varied configuration and length of threads in successively formed courses. Due to the repeatability of elements within its stitch repeat, the chain stitch is an isomorphous loop structure. The weft stitch consists of three repeatable elements  $a_{r,k}$  - type '1', '2' and '3' arranged in the

$$R_k \cdot m \cdot \frac{d^2 y}{dt^2} + R_k \cdot k_s \cdot y = \sum_{k=1}^{R_k} (\cos \beta - e^{\pm\mu\rho} \cdot \sin \alpha) \cdot P_{1k} \quad (1)$$

$$P_{1k} = k_p \cdot \frac{\lambda_{1k}}{l_1} + \frac{b_p}{l_1} \cdot \frac{d\lambda_{1k}}{dt} \quad (3)$$

$$P_{2k} = k_p \cdot \frac{\lambda_{2k}}{l_2} + \frac{b_p}{l_2} \cdot \frac{d\lambda_{2k}}{dt} \quad (4)$$

$$\frac{k_p}{l_1} \cdot \lambda_{1k} \cdot e^{\pm\mu\rho} + \frac{b_p}{l_1} \cdot e^{\pm\mu\rho} \cdot \frac{d\lambda_{1k}}{dt} = \frac{k_p}{l_2} \cdot \lambda_{2k} + \frac{b_p}{l_2} \cdot \frac{d\lambda_{2k}}{dt} \quad (5)$$

$$\frac{k_p}{l_1} \cdot \lambda_{1k} \cdot e^{\pm\mu\rho} + \frac{b_p}{l_1} \cdot e^{\pm\mu\rho} \cdot \frac{d\lambda_{1k}}{dt} = \frac{k_p}{l_2} [S(t)_k - \lambda_{1k} - y(\cos \beta - \sin \alpha)] + \frac{b_p}{l_2} \left[ \frac{dS(t)_k}{dt} - \frac{d\lambda_{1k}}{dt} - \frac{dy}{dt} (\cos \beta - \sin \alpha) \right] \quad (8)$$

$$\frac{k_p}{l_1} \cdot \lambda_{1k} + \frac{b_p}{l_1} \cdot \frac{d\lambda_{1k}}{dt} = \frac{k_p}{l_2 \cdot e^{\pm\mu\rho} + l_1} \cdot S(t)_k + \frac{b_p}{l_2 \cdot e^{\pm\mu\rho} + l_1} \cdot \frac{dS(t)_k}{dt} - \frac{k_p \cdot (\cos \beta - \sin \alpha)}{l_2 \cdot e^{\pm\mu\rho} + l_1} \cdot y - \frac{b_p \cdot (\cos \beta - \sin \alpha)}{l_2 \cdot e^{\pm\mu\rho} + l_1} \cdot \frac{dy}{dt} \quad (9)$$

$$R_k \cdot m \cdot \frac{d^2 y}{dt^2} + b_{2r} \cdot \frac{dy}{dt} + k_{2r} \cdot y = a_1 \cdot \left[ k_p \cdot \sum_{k=1}^{N_1} S(t)_{k(1)} + b_p \cdot \sum_{k=1}^{N_1} \frac{dS(t)_{k(1)}}{dt} \right] + a_2 \cdot \left[ k_p \cdot \sum_{k=1}^{N_2} S(t)_{k(2)} + b_p \cdot \sum_{k=1}^{N_2} \frac{dS(t)_{k(2)}}{dt} \right] + a_3 \cdot \left[ k_p \cdot \sum_{k=1}^{N_3} S(t)_{k(3)} + b_p \cdot \sum_{k=1}^{N_3} \frac{dS(t)_{k(3)}}{dt} \right] \quad (10)$$

Equations 1, 3, 4, 5, 8, 9, and 10.

repeat surface according to the plastic design of the fabric pattern (Figure 2a).

The pattern recorded in the form of coloured squares (c - red, z - green, b - white) contains information on the surface distribution of weft threads in one wale (element '1') or joining two (element '2') or three wales (element '3') of the first component stitch. An anisotropical system of single elements of the weft stitch structure was recorded in the form of a numerical matrix  $A_2$  (Figure 2b), on the basis of the defined principles of stitch coding. The numerical matrix  $A_2$  clearly defines the anisotropic character of the fabric structure, and is the key parameter in identifying the variability of the fabric features as well as the technology of its production. The algorithm (Table 1) parameters of the fabric structure were defined according to step 2: course height  $B=0.95$  mm, wale width  $A=2.80$  mm, chain stitch thread diameter  $d_f=0.14$  mm (polyester yarn of linear density 13.3 tex), weft thread diameter  $d_w=0.2$  mm (polyester yarn of linear density 29.4 tex). The thread lengths in chain loops and in wefts, calculated according to an open geometrical model, are:  $l_{f1}=3.4$  mm,  $l_{w1}=1.2$  mm,  $l_{w2}=3.9$  mm,  $l_{w3}=7$  mm (relative error  $\epsilon l=1.9\%$ ). By assigning the values of thread lengths in elements ( $a_{r,k}=l_{r,k}$ ) to the elements  $a_{r,k}$  of matrix  $A_2$ , we obtain matrix  $L_2$ .

For method 'A', that is feeding a constant thread length equal to the average requirement  $l_z$  in the stitch repeat, the gradients of the thread run-ins  $\Delta l_{r,k}$  were determined. The quantities

$$\Delta w_{r,k} = \frac{\Delta r_{r,k}}{B}$$

were shown in the lined fields of the thread run-in matrix  $V_2$  (Figure 2c). For step 6, the algorithm Table 1 components of kinematic forcing  $\Delta S_{r,k}$  were determined, where:

$$\Delta S_{r,k} = -\Delta l_{r,k}$$

Thus, for the successive four weft threads  $\Delta S_{r,k}$  expressed in mm:

- for  $k_1$ :  $\Delta S_{1,1} = -2.3$ ,  $\Delta S_{2,1} = -2.2$ ,  $\Delta S_{3,1} = -2.1$ ,  $\Delta S_{4,1} = -2.0$ ,  $\Delta S_{5,1} = 1.0$ ,  $\Delta S_{6,1} = 1.1$
- for  $k_2$ :  $\Delta S_{1,2} = 0.1$ ,  $\Delta S_{2,2} = 0.2$ ,  $\Delta S_{3,2} = 3.2$ ,  $\Delta S_{4,2} = 3.3$ ,  $\Delta S_{5,2} = 1.0$ ,  $\Delta S_{6,2} = 1.1$
- for  $k_3$ :  $\Delta S_{1,3} = 3.0$ ,  $\Delta S_{2,3} = 3.1$ ,  $\Delta S_{3,3} = 0.8$ ,  $\Delta S_{4,3} = 0.9$ ,  $\Delta S_{5,3} = 1.0$ ,  $\Delta S_{6,3} = 1.1$

$$b_{cr} = b_p (\cos \beta - \sin \alpha) \cdot (a_1 \cdot N_1 + a_2 \cdot N_2 + a_3 \cdot N_3) \quad (17)$$

$$k_{rz} = N_1 \cdot [k_s + a_1 \cdot (\cos \beta - \sin \alpha) \cdot k_p] + N_2 \cdot [k_s + a_2 \cdot (\cos \beta - \sin \alpha) \cdot k_p] + N_3 \cdot [k_s + a_3 \cdot (\cos \beta - \sin \alpha) \cdot k_p] \quad (18)$$

$$\frac{d^2 y}{dt^2} + 2h \cdot \frac{dy}{dt} + \omega_0^2 \cdot y = \frac{1}{R_k \cdot m} \cdot \left\{ \begin{aligned} & a_1 \left[ k_p \cdot \sum_{k=1}^{N_1} S(t)_{k(1)} + b_p \cdot \sum_{k=1}^{N_1} \frac{dS(t)_{k(1)}}{dt} \right] + \\ & a_2 \left[ k_p \cdot \sum_{k=1}^{N_2} S(t)_{k(2)} + b_p \cdot \sum_{k=1}^{N_2} \frac{dS(t)_{k(2)}}{dt} \right] + \\ & a_3 \left[ k_p \cdot \sum_{k=1}^{N_3} S(t)_{k(3)} + b_p \cdot \sum_{k=1}^{N_3} \frac{dS(t)_{k(3)}}{dt} \right] \end{aligned} \right\} \quad (21)$$

$$P_1(t) = \frac{1}{l_2 \cdot e^{\mu p} + l_1} \cdot \left[ \begin{aligned} & k_p \cdot S(t)_{k(1)} + b_p \cdot \frac{dS(t)_{k(1)}}{dt} - k_p \cdot (\cos \beta - \sin \alpha) \cdot y - \\ & - b_p \cdot (\cos \beta - \sin \alpha) \cdot \frac{dy}{dt} \end{aligned} \right] \quad (22)$$

$$P_1(t)_{(2)} = \frac{1}{l_2 \cdot e^{-\mu p} + l_1} \cdot \left[ \begin{aligned} & k_p \cdot S(t)_{k(2)} + b_p \cdot \frac{dS(t)_{k(2)}}{dt} - k_p \cdot (\cos \beta - \sin \alpha) \cdot y - \\ & - b_p \cdot (\cos \beta - \sin \alpha) \cdot \frac{dy}{dt} \end{aligned} \right] \quad (23)$$

$$P_1(t)_{(3)} = \frac{1}{l_2 + l_1} \cdot \left[ \begin{aligned} & k_p \cdot S(t)_{k(3)} + b_p \cdot \frac{dS(t)_{k(3)}}{dt} - k_p \cdot (\cos \beta - \sin \alpha) \cdot y - \\ & - b_p \cdot (\cos \beta - \sin \alpha) \cdot \frac{dy}{dt} \end{aligned} \right] \quad (24)$$

Equations 17, 18, 21, 22, 23, and 24.

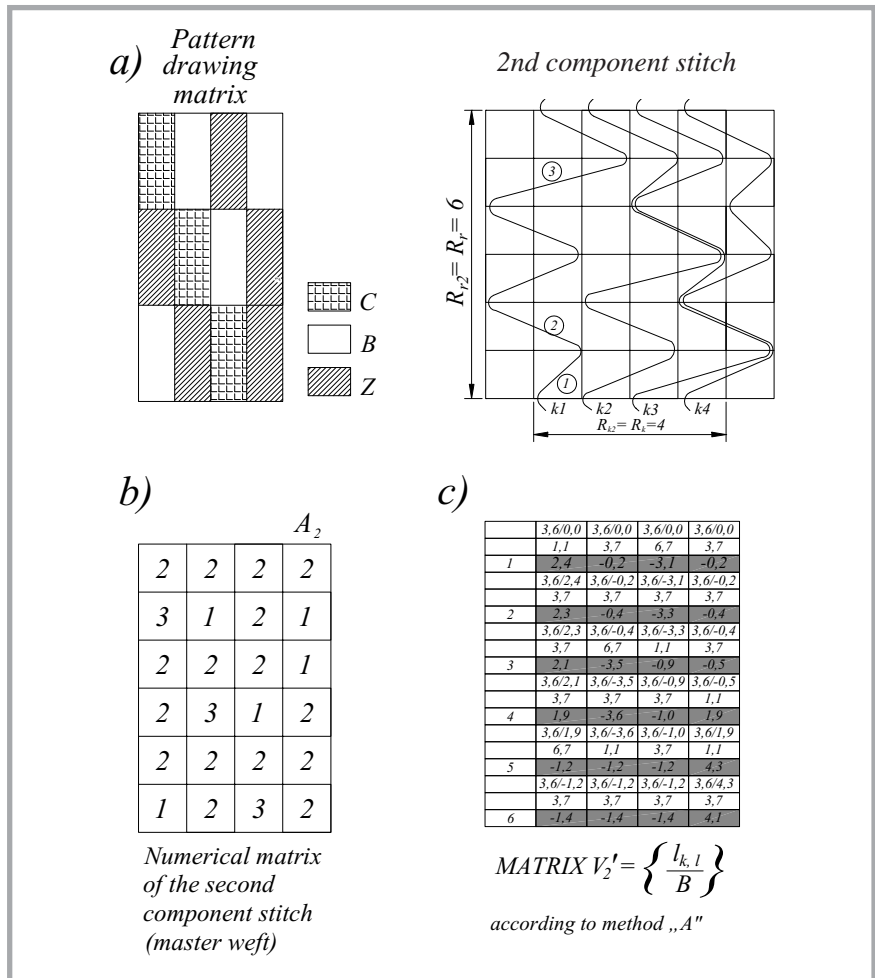

Figure 2. A mathematical model of fabric structure.

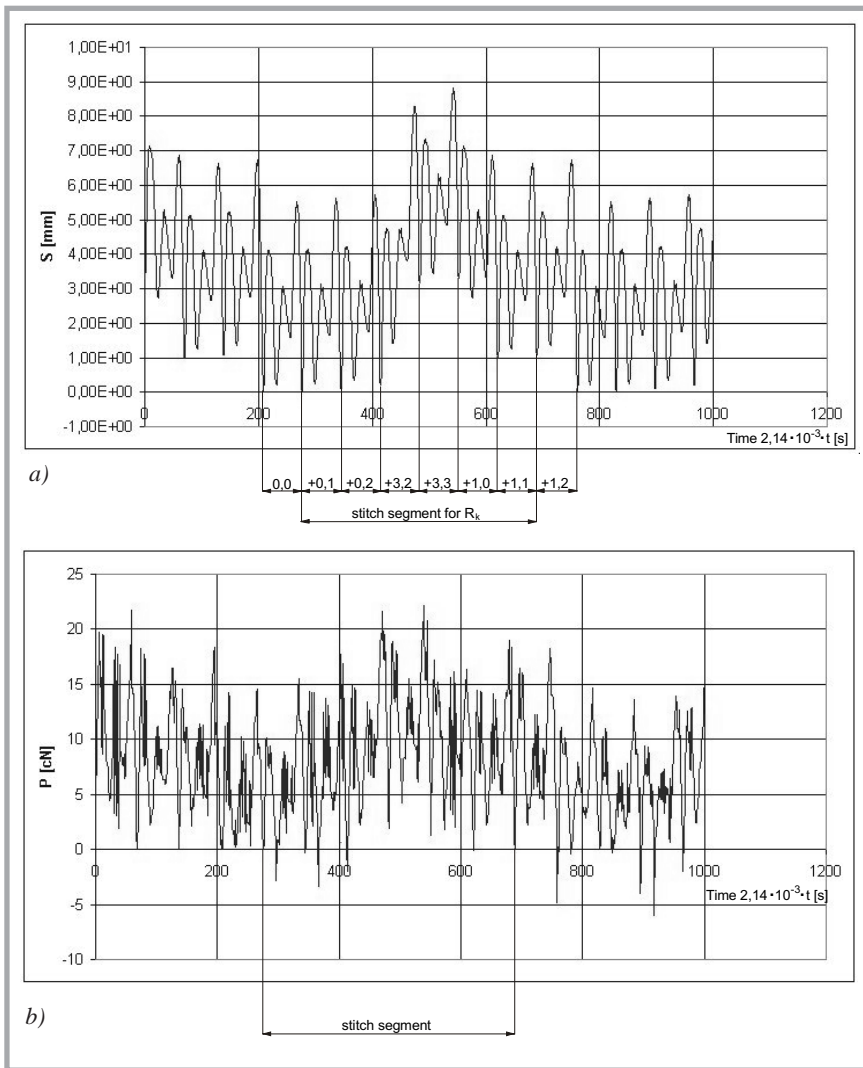

Figure 3. a) Forcing  $S(t)$  for the weft thread  $k_2$ ; b) A time course of dynamic forces in thread  $k_2$ .

- for  $k_4$ :  $\Delta S_{1,4} = 0.1$ ,  $\Delta S_{2,4} = 0.2$ ,  
 $\Delta S_{3,4} = 0.3$ ,  $\Delta S_{4,4} = -2.0$ ,  $\Delta S_{5,4} = -4.3$ ,  
 $\Delta S_{6,4} = 4.2$ .

For calculations of the back rest roller displacements  $y(t)$  and dynamic loads of threads  $P_k(t)$ , the following input data was taken (symbols as in Figure 1):  $m=3.7$  g;  $k_s=0.51$  cN/mm;  $k_p=4680$  cN;  $b_p=2100$  cNms;  $\mu=0.2$ ;  $l_j=723$  mm;  $l_2=1344$  mm;  $\alpha=46^\circ$ ;  $\beta=34^\circ$ ; knitting speed  $n=400$  courses/min;  $Nu=18/2$ "E. The final result, in the form of an example time course of forces in the thread  $k_2$  for forcing  $S(t)$ , is presented in Figures 3a and 3b.

## Conclusions

The mathematical model of the feeding process for anisostuctural warp knitted fabrics, with defined assumptions of the dynamic system of constant-length thread feeding for the forcing reflecting variable parameters of the fabric structure and features of the knitting process on warp-knit-

ting machines, should be helpful in selecting optimum conditions for the knitting process. This optimisation is defined by the limiting values of forces in threads  $P_{max}$  and  $P_{min}$ . Beyond these values, especially for  $P_{min} > P > P_{max}$ , disturbances of the knitting process occur, which further leads to unfavourable changes in the fabric structure.

## References

1. Z. Mikołajczyk, Digital Identification of Yarn Take-Up Gradient in Anisotropic Warp Knitted Fabrics. *Zeszyty Naukowe, Włókiennictwo No. 58, 6th International Textile Conference IMTEX '2000*, p. 209-218.
2. Z. Mikołajczyk, Model of Spatial Structure of Anisotropic Warp Knitted Fabrics. *Fibres & Textiles in Eastern Europe*, Vol. 9, No. 2(33) April/June 2001, p. 23-27.

Received 11.12.2002 Reviewed 20.04.2003

# Institute of Chemical Fibres

FIBRES & TEXTILES  
in Eastern Europe

ul. Skłodowskiej-Curie 19/27  
90-570 Łódź, Poland

Tel.: (48-42) 637-65-10,  
637-60-02

Fax: (48-42) 637-65-01

e-mail:

iwch@mazurek.man.lodz.pl

Internet:

http://www.iwch.lodz.pl

We accept articles and information on all problems and aspects concerning the manufacture, production, application, and distribution of fibres and textiles in Central and Eastern Europe. We're seeking information, commentary, and articles related to the scope of our journal from all over the world in order to create an information network which will encourage cooperation, the exchange of experience, and lead to profitable business and research contacts.

**Write us !**